

# DIVISORS AND MULTIPLICITIES UNDER TROPICAL AND SIGNED SHADOWS

A Dissertation  
Presented to  
The Academic Faculty

By

Trevor Gunn

In Partial Fulfillment  
of the Requirements for the Degree  
Doctor of Philosophy in the  
School of Mathematics

Georgia Institute of Technology

August 2023

© Trevor Gunn 2023

# DIVISORS AND MULTIPLICITIES UNDER TROPICAL AND SIGNED SHADOWS

Thesis committee:

Dr. Matthew Baker (Advisor)  
School of Mathematics  
*Georgia Institute of Technology*

Dr. Oliver Lorscheid  
Bernoulli Institute  
*University of Groningen*

Dr. Grigoriy Blekherman  
School of Mathematics  
*Georgia Institute of Technology*

Dr. Josephine Yu  
School of Mathematics  
*Georgia Institute of Technology*

Dr. Anton Leykin  
School of Mathematics  
*Georgia Institute of Technology*

Date approved: June 20, 2023

... allowing a little more time for things to go wrong might in fact have been a better idea.  
I'd just been completely certain that if they'd gone more wrong than that, we'd all be dead  
anyway.

*Naomi Novik, A Deadly Education*

For my friends

## ACKNOWLEDGMENTS

First and foremost, I would like to thank my advisor Matt Baker, for all his support over the years: both on academic and non-academic matters. Thank you for connecting me with my coauthors and helping me go to conferences. Thank you for your advice on teaching, presenting, time-management, careers, the High School Math Day. Thank you for helping find references, journals and correcting my work.

Next, I am thankful to the committee members. Thank you Josephine, for answering so many questions over the years and sitting down with Andreas and I to talk about tropical intersection theory. Thank you Oliver, for inviting me to your seminar on tropical scheme theory and for your notes and papers that helped me learn. Thank you Greg, for teaching me about Gröbner bases and toric varieties, for supporting the algebra student seminar, and for all your advice over the years. Thank you Anton, for your support over the years and for your computational group that helped broaden my perspective, including Justin Chen, Tim Duff, Marc Härkönen and Kisun Lee.

I am thankful to Joe Rabinoff for teaching me about schemes and sheaves and for answering my questions about non-Archimedean geometry. Thank you for your support in attending the Arizona Winter School.

I thank my two coauthors: Philipp Jell and Andreas Gross. Thank you for teaching me about tropical and non-Archimedean geometry and for working with me on these projects. Thank you also for bringing me to Germany and thanks to Universität Regensburg for hosting NATROP.

Thank you to all my teachers and mentors over the years. In particular, my undergrad research mentors David Jackson and Matt Satriano for introducing me to research. Also, many thanks to Mo Burke and Klara Grodzinsky for mentoring me in teaching. I am also thankful to all my students for their feedback and comments over the years.

Thank you to Lea Marzo, Melissa Raine, Wade Bloomquist, Evelyne Smith-Roberge,

Sal Barone, Jeff Lowe and Mike Wolf—not to mention the numerous volunteers—for working with me on creating the High School Math Day. Thank you to Chris Jankowski for introducing me to the original High School Math Competition.

Thank you to all my friends and colleagues at Georgia Tech for conversations on math, life, puzzles or organizing events with me: Jose Acevedo, Santana Afton, Sal Barone, Wade Bloomquist, Adam Brown, Mo Burke, Katherine Booth, Marcel Celaya, Justin Chen, Abhishek Dhawen, Tim Duff, Chris Dupre, Christina Giannitsi, Cvetelina Hill, Daniel Hwang, Chris Jankowski, Tong Jin, Jaewoo Jung, Sierra Knavel, Ian Lewis, Stephen McKean, Dan Minahen, Mirabel Reid, Stephanie Reikes, Roberta Shapiro, Evelyne Smith-Roberge, Kevin Shu, Youngho Yoo, Chi-Ho Yuen, Tianyi Zhang. My apologies if I left anyone out.

Lastly, thank you to my friends outside of Georgia Tech: Ashley, Catherine, Constanza, David, Ignacio, Jessie, Kjell, Macarena, Travis.

## TABLE OF CONTENTS

<b>Acknowledgments</b>	<b>v</b>
<b>List of Tables</b>	<b>xii</b>
<b>List of Figures</b>	<b>xiii</b>
<b>Summary</b>	<b>xvi</b>
<b>1 Introduction</b>	<b>1</b>
1.1 Faithful and fully-faithful tropicalization . . . . .	4
1.1.1 Smooth tropicalizations . . . . .	6
1.2 Berkovich analytic spaces and constructing tropicalizations . . . . .	6
1.2.1 Faithful and fully-faithful tropicalization . . . . .	8
1.3 Tropical multiplicities . . . . .	9
1.4 The Descartes' Problem . . . . .	9
1.4.1 Itenberg and Roy's theorem and conjecture . . . . .	10
1.4.2 Mixed sparse resultants . . . . .	11
1.5 Hyperfields and Baker-Lorscheid multiplicities . . . . .	12
1.5.1 The sign hyperfield . . . . .	12
1.5.2 The tropical hyperfield . . . . .	13
1.6 Tropical extensions . . . . .	13
1.6.1 Relative multiplicities . . . . .	15
1.7 Multivariate multiplicities . . . . .	15

1.7.1	Morphisms and multiplicities . . . . .	17
<b>I</b>	<b>Divisors on Metric Graphs</b>	<b>19</b>
<b>2</b>	<b>Construction of fully faithful tropicalizations for curves in ambient dimension 3</b>	<b>20</b>
2.0.1	Fully and totally faithful tropicalizations . . . . .	20
2.0.2	Smooth tropicalizations . . . . .	22
2.0.3	Structure . . . . .	23
2.0.4	Acknowledgements . . . . .	24
2.1	Preliminaries . . . . .	24
2.1.1	Tropicalization of curves in $\mathbf{P}^n$ . . . . .	24
2.1.2	Limits in $\mathbf{TP}^n$ . . . . .	25
2.1.3	Metric graphs . . . . .	26
2.1.4	Berkovich analytic spaces . . . . .	27
2.1.5	Skeleta and extended skeleta of curves . . . . .	28
2.1.6	Tropicalization of analytic curves . . . . .	30
2.1.7	Fully faithful, totally faithful and smooth . . . . .	31
2.1.8	Divisors and rational functions on a metric graph . . . . .	32
2.1.9	Mumford curves . . . . .	33
2.2	Construction of fully faithful tropicalization in 3-space . . . . .	34
2.2.1	Constructions of the piecewise-linear functions and lifting . . . . .	35
2.3	The right choice of parameters . . . . .	37
2.3.1	Interval condition . . . . .	38
2.3.2	Conditions for $r(v)$ . . . . .	38
2.3.3	Further requirements on locations . . . . .	40



2.3.4	Conditions for $s(e)$ . . . . .	40
2.4	Injectivity . . . . .	41
2.4.1	Infinite rays . . . . .	43
2.5	Fully and totally faithfulness . . . . .	49
2.6	Resolution of singularities . . . . .	50
2.6.1	A conceptual approach . . . . .	50
2.6.2	Application to our situation . . . . .	53
2.7	A genus 2 curve . . . . .	54
2.7.1	Picturing the construction . . . . .	55
2.7.2	A proper construction . . . . .	57
2.7.3	Injective, smooth and fully-faithful . . . . .	58
<b>II</b>	<b>Multiplicities over Hyperfields</b>	<b>64</b>
<b>3</b>	<b>Tropical extensions and Baker-Lorscheid multiplicities for idylls</b>	<b>65</b>
3.0.1	Structure of the chapter and a rough statement of the results . . . . .	67
3.0.2	Relationship to other papers . . . . .	74
3.0.3	Acknowledgements . . . . .	75
3.1	Idylls and Ordered Blueprints . . . . .	76
3.1.1	Ordered Blueprints . . . . .	77
3.1.2	Morphisms of Ordered Blueprints . . . . .	82
3.1.3	Images, Equalizers and Subblueprints . . . . .	85
3.2	Polynomial and Tropical Extensions . . . . .	86
3.2.1	Newton Polygons and Initial forms . . . . .	89
3.2.2	Initial Forms . . . . .	90

3.3	Factoring Polynomials and Multiplicities over Idylls . . . . .	93
3.3.1	Roots of Polynomials . . . . .	93
3.3.2	Multiplicities . . . . .	96
3.4	Hyperfields . . . . .	99
3.5	Lifting Theorem for Multiplicities . . . . .	102
3.6	Examples and Connections . . . . .	108
3.6.1	Higher rank . . . . .	109
3.6.2	Connection to polynomials over fields . . . . .	110
<b>4</b>	<b>Factoring multivariate polynomials over hyperfields and the multivariable</b>	
	<b>Descartes' problem</b>	<b>114</b>
4.0.1	Descartes' rule and hyperfields . . . . .	115
4.0.2	Linear factors of multivariate polynomials . . . . .	116
4.0.3	Subdivisions, Geometry and Multiplicities . . . . .	119
4.0.4	Systems of equations . . . . .	120
4.0.5	Acknowledgement . . . . .	122
4.0.6	Notation . . . . .	122
4.1	Fields and Hyperfields . . . . .	123
4.1.1	Tropical Extensions . . . . .	126
4.1.2	Morphisms . . . . .	128
4.1.3	Valuations . . . . .	128
4.1.4	Real fields . . . . .	130
4.2	Polynomials over hyperfields . . . . .	131
4.2.1	Newton Polygons . . . . .	133

4.2.2	Polynomial Functions . . . . .	135
4.2.3	Initial forms . . . . .	136
4.2.4	Tropical Hypersurfaces . . . . .	137
4.3	Factoring multivariate polynomials over hyperfields . . . . .	138
4.3.1	The hyperfield multiplicity . . . . .	138
4.3.2	The boundary multiplicity . . . . .	140
4.3.3	Multiplicities and initial forms . . . . .	142
4.3.4	The geometric multiplicity . . . . .	145
4.3.5	Relative hyperfield multiplicity . . . . .	152
4.3.6	Perturbation multiplicity . . . . .	155
4.3.7	Multiplicities over $S$ in degree 2 . . . . .	160
4.4	Systems of equations over hyperfields . . . . .	166
4.4.1	Sparse resultants . . . . .	167
4.4.2	Tropically transverse intersections . . . . .	170
4.4.3	Resultants over hyperfields . . . . .	178
<b>A Factorization Rules</b>		<b>182</b>
<b>References</b>		<b>185</b>

## LIST OF TABLES

2.1	Directions of infinite rays and their limit in $\mathbf{TP}^3$ and $(\mathbf{TP}^1)^3$ . . . . .	43
2.2	Divisors on $\Gamma$ and on $X^{\text{an}}$ . Lifts are chosen first for $D_1$ , then $D_2$ , then $D_3$ . . .	57

## LIST OF FIGURES

1.1	A genus 1 graph. . . . .	1
1.2	The tropical line $\text{Trop}(V(x + y = 1))$ . . . . .	2
1.3	Extended Newton polytope, <b>Newton complex</b> and tropicalization of $f$ . . . . .	3
1.4	The tropical balancing condition, weights written as numbers. . . . .	3
1.5	Tropicalization of a metric graph. . . . .	4
1.6	Baker-Rabinoff coordinate functions along a fixed edge. . . . .	5
1.7	The Berkovich affine line (with the hole at $\infty$ pictured). . . . .	7
1.8	Newton polygon for $\min\{3x, x + 2, 4\}$ . . . . .	9
1.9	Graph of $y = 1 - 3x - 2x^2 + x^5$ showing one negative and two positive zeroes. . . . .	10
1.10	A multiple of the signed sparse resultant in the Li-Wang example. A * means the sign is undetermined. . . . .	12
1.11	Sign compatible subdivision, quotient with induced subdivision, and associated dual arrangement. . . . .	16
2.1	Boundary strata of $\mathbb{TP}^2$ . Parallel rays in the directions $(-1, 0)$ , $(0, -1)$ or $(1, 1)$ intersect the boundary in distinct points. Rays in any other direction intersect the closest corner. . . . .	26
2.2	The graph of $F_1 _e$ . . . . .	39
2.3	The graph of $F_3 _e$ . . . . .	39
2.4	The graph of $F_2 _e$ for $e \in T$ . . . . .	39

2.5	The graph of $F_2 _e$ for $e \notin T$ . . . . .	39
2.6	Where the points lie on the real line. . . . .	39
2.7	Situation in Lemma 2.4.5 . . . . .	47
2.8	The graph of $F_{e_k}(v)$ along the edges $e_k(v)$ and $e_0(v)$ . The function $F_{e_k}$ is constant 0 on all other edges. . . . .	51
2.9	First step of Wagner’s construction of a tropicalization of a genus two curve with an intersection circled. . . . .	55
2.10	First draft of how the genus 2 skeleton is embedded in $\mathbf{TP}^3$ . . . . .	55
2.11	Skeleton $\Gamma$ of $X$ . . . . .	56
2.12	$\alpha_2$ and its lifts (dashed lines are infinite). . . . .	58
2.13	The $x = y$ and $z = 0$ planes in our construction. Dashed lines represent where the other hexagons are (outside the planes). . . . .	59
2.14	Position of the new rays added from the rough draft. . . . .	60
2.15	Where the rays in $-x$ and $-y$ direction originate at $\gamma_2, \gamma_3$ . Projection onto the $x = 0$ and $y = 0$ planes. . . . .	61
3.1	Newton polygons of $(x + 3)(x - 4)(x - 6)$ in $\mathbf{Q}_2$ and $\mathbf{Q}_3$ respectively . . .	66
3.2	Euler diagram of relationships between sub-categories of ordered blueprints	67
3.3	Newton polygon of $f$ in Example 3.2.17 . . . . .	90
3.4	Newton polygon describing the construction . . . . .	106
3.5	Newton polygon of $f$ with respect to $v_s$ in Example 3.6.4 . . . . .	110
3.6	Newton polygon of $\text{in}_1 \text{trop}(f)$ in Example 3.6.4 . . . . .	110
4.1	Possible sign patterns which arise from intersecting a line with the unit circle.	115
4.2	Extended Newton polytope of the polynomial $f = 1 + x + y + x^2 + xy + 1y^2 \in \mathbf{T}[x, y]$ and associated subdivision of $\text{Newt}(f)$ . Numbers indicate the valuation of the corresponding coefficient. . . . .	134

4.3	Tropical curves defined by $0 + x + y + 2x^2 + 1xy + 2y^2$ and $0 + x + y$ . . .	143
4.4	Newton subdivision of $f = 0 + x + y + 1x^3 + 1x^2y + 2y^3$ and associated tropical curve $V(f)$ . . . . .	146
4.5	Sign compatible subdivision, quotient with induced subdivision, and associated tropical hypersurfaces. . . . .	158
4.6	Transformations $x \leftrightarrow -x, y \leftrightarrow -y, z \leftrightarrow -z$ . . . . .	162
4.7	The 4 cases of Newton-degree 2 sign configurations and subdivisions. . . .	163
4.8	The 3 non-dense cases needed to be checked after all reductions. . . . .	165
4.9	The only Newton subdivision including the support of $1 - x^2 + xy - y^2$ as vertices. . . . .	166
4.10	A multiple of the signed sparse resultant of $f, g$ and $l$ . A * means the sign is undetermined. . . . .	180

## SUMMARY

This thesis addresses questions related to divisors and multiplicities as analyzed through tropicalization or signs. It begins with an introduction to the subject matter written for a non-specialist. The next chapter concerns fully-faithful tropicalization in low dimension. The last two chapters concern questions about Baker-Lorscheid multiplicities in one and several variables respectively.

With fully-faithful tropicalization, the goal was to construct a tropicalization map from a curve to a 3-dimensional toric variety. The constraints are that we need the map to be injective and we need the gcd of all the slopes to be 1, so that we get an isometry with respect to the lattice length metric. We also have some results about smooth, fully-faithful tropicalizations of a genus  $g$  curve in a toric variety of a dimension  $2g + 2$  (three more than the lower bound imposed by the maximal vertex degree).

For multiplicities, I present a broad generalization of the work of Baker and Lorscheid for univariate multiplicities over hyperfields. In Baker and Lorscheid's work, they show how Descartes's Rule of Signs and Newton's Polygon Rule may be obtained from factorizing polynomials in the arithmetics of signs and tropical numbers respectively. We will see in chapter 3, a broad generalization of their multiplicity operator to a class of arithmetics, which I call "whole-idylls." In particular, we have a way of extending multiplicity rules by extending the arithmetic by a valuation. An important corollary is that for so-called "stringent" hyperfields, we have a degree bound: the sum of multiplicities for a polynomial is bounded by its degree.

The last chapter contains my work with Andreas Gross on multivariate hyperfield multiplicities. We give particular attention to the hyperfield of signs and the so-far-unresolved Multivariate Descartes Question. We define several multiplicity operators for linear factors of polynomials and apply them to systems of equations. We recover the lower bound of Itenberg-Roy on any potential upper bound for roots with a given sign pattern.



# CHAPTER 1

## INTRODUCTION

A smooth, genus 1 curve is called an *elliptic curve* and the theory of such curves is extensive, having connections to Diophantine equations, modular forms, cryptography and more. A genus 1 graph, on the other hand, is simpler: consisting of a unique cycle with trees branching off. On their face, these two worlds seem quite disparate, but there is in fact a wardrobe connecting them, known as *tropicalization*.

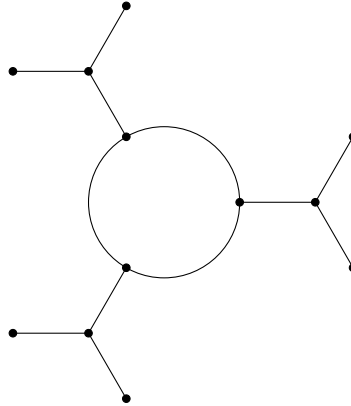

Figure 1.1: A genus 1 graph.

Consider the field  $\mathbf{Q}_p$  of  $p$ -adic numbers. Elements of  $\mathbf{Q}_p$  are expressed as Laurent series in  $p$ , which take the form  $z = \sum_{n \geq N} a_n p^n$  for some  $N \in \mathbf{Z}$  and  $a_n \in \{0, \dots, p-1\}$ . Given an element  $z$ , we define the function  $v_p(z) = \min\{n : a_n \neq 0\} \in \mathbf{Z}$  and call it the  $p$ -adic valuation, an instance of a *non-Archimedean valuation*. If  $z \in \mathbf{Q} \subset \mathbf{Q}_p$ , then  $v_p(z) = k$  if we can write  $z = p^k \frac{a}{b}$  with  $p \nmid ab$ . The valuation  $v_p$  (more generally: every non-Archimedean valuation) satisfies the following properties:

- $v_p(0) = +\infty$  (by convention),
- $v_p(wz) = v_p(w) + v_p(z)$ ,
- $v_p(w + z) \geq \min\{v_p(w), v_p(z)\}$  with equality if  $v_p(w) \neq v_p(z)$ .

This last property implies that  $|z|_p := p^{-v_p(z)}$  satisfies the (ultra)triangle inequality  $|w+z|_p \leq \max\{|w|_p, |z|_p\} \leq |w|_p + |z|_p$ . We call this a *non-Archimedean absolute value*.

Given a curve  $X \subset (\mathbf{Q}_p^*)^n$ , we can consider the image  $v_p(X(\overline{\mathbf{Q}_p})) \subset \mathbf{Q}^n$  and then take the Euclidean closure to obtain a set in  $\mathbf{R}^n$  called its *tropicalization*, denoted

$$\text{Trop}(X) = \overline{\{(v_p(x_1), \dots, v_p(x_n)) : (x_1, \dots, x_n) \in X(\overline{\mathbf{Q}_p})\}}. \quad (1.1)$$

**Example 1.0.1.** Take the curve defined by  $x + y = 1$ . The properties above imply that the minimum of  $v_p(x), v_p(y), v_p(-1) = 0$  occurs at least twice because if the minimum were unique then  $v_p(x + y - 1) = \min\{v_p(x), v_p(y), v_p(-1)\} \neq v_p(0)$  implies  $x + y - 1 \neq 0$ . The set of points in  $\mathbf{R}^2$  where the minimum of  $x, y, 0$  occurs at least twice is called a *tropical line* (Figure 1.2). ◇

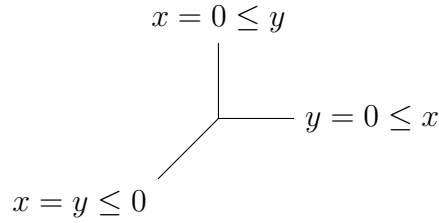

Figure 1.2: The tropical line  $\text{Trop}(V(x + y = 1))$ .

Given a complicated polynomial, such as

$$f(x, y) = p^3 + px + py + px^2 + xy + py^2 + p^3x^3 + px^2y + pxy^2 + p^3y^3,$$

it is harder to use (1.1) to draw the tropicalization. Fortunately, there is a trick! First, plot the points  $(i, j)$  for  $(i, j) \in \text{supp}(f)$  and imagine lifting them to a height of  $v_p(c_{i,j}) \in \mathbf{R}^3$ , where  $c_{i,j}$  is the coefficient of  $x^i y^j$ . Then, imagine wrapping those points from the bottom in plastic. Keep track of the edges and faces created in this process and use those to construct a subdivision of the Newton polygon  $\text{conv}(\text{supp}(f)) \subset \mathbf{R}^2$ . This subdivision is called the Newton complex, denoted  $\text{Newt}(f)$ . The tropicalization,  $\text{Trop}(V(f))$ , is dual to  $\text{Newt}(f)$ ,

after rotating  $180^\circ$ . This is a *tropical elliptic curve* (Figure 1.3). The vertices of the tropical curve correspond to maximal cells in the Newton complex. To get the coordinates of a vertex, the quantities  $v_p(c_{i,j}) + ix + jy$  should be equal (and minimal) for all  $(i, j)$  in that maximal cell.

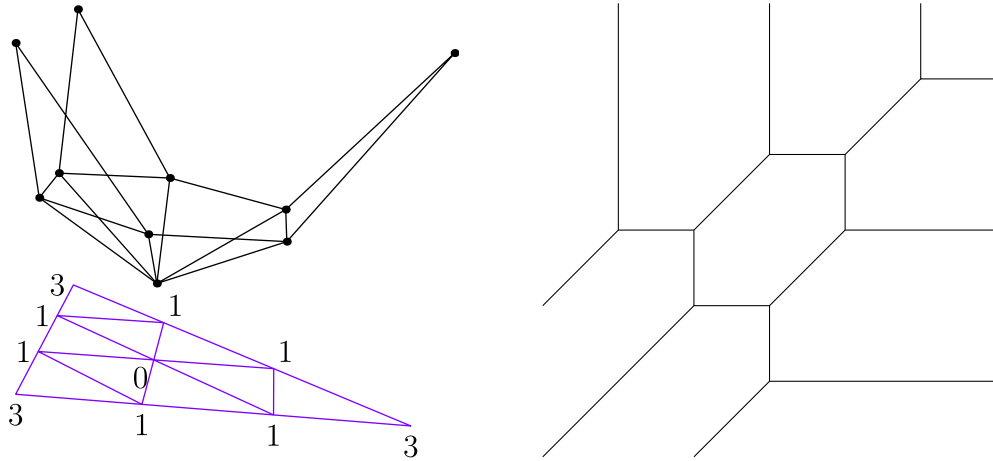

Figure 1.3: Extended Newton polytope, [Newton complex](#) and tropicalization of  $f$ .

Tropical curves also have a balancing condition. For each cell  $\sigma$  in the Newton complex, consider the minimal integer normal vector  $v_e$  to each edge  $e$  of  $\sigma$ . Give this a weight  $w_e$  which is the index of the minimal integer vector in  $e$  (the number of times  $e$  is a multiple of its minimal integer vector). Then  $\sum_{e \in \sigma} w_e v_e = 0$ , which we can see because if we stack the vectors  $w_e v_e$  from tip to tail, we get a rotation of  $\sigma$ , which is a closed loop (Figure 1.4).

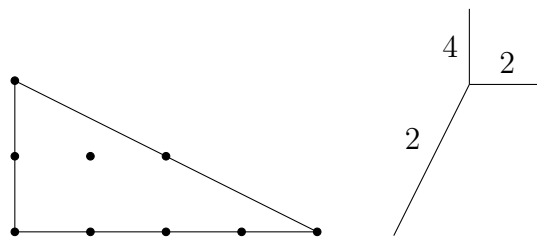

Figure 1.4: The tropical balancing condition, weights written as numbers.

## 1.1 Faithful and fully-faithful tropicalization

A metric graph is a graph where every edge has a length. In the context of tropicalization, edges will have infinite length if and only if they connect to a leaf vertex. This is an abstraction of the tropical curves as pictured in Figure 1.3 where the lengths are given by the lattice lengths (e.g.  $(4, 2)$  has a lattice length of 2 since it is twice as long as the minimal integer vector  $(2, 1)$ ). In the tropical picture, these lattice lengths are scaled by the weights described by Figure 1.4. For instance, if  $(2x, x)$  is a point on an edge in direction  $(2, 1)$  from the origin, and that edge has a weight of 3, then  $(2x, x)$  is distance  $3x$  from the origin. If we forget the exact coordinates and just remember lengths and distances, we get a metric graph, which we call an *abstract tropical curve*.

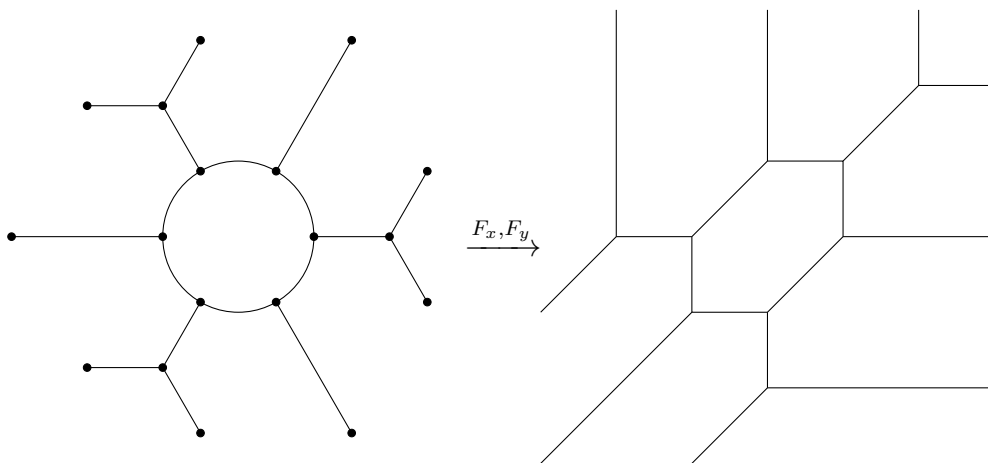

Figure 1.5: Tropicalization of a metric graph.

Notice that tropical curves, as defined in (1.1) and pictured in Figure 1.3, can be obtained from metric graphs using piecewise-linear coordinate functions (Figure 1.5). For curves over  $\mathbb{Q}_p$ , these coordinate functions have integral slopes and have rational lengths in the lattice length metric.

Baker and Rabinoff, in an application of their theory [BR15, Section 8], describe tropicalization maps which are isometries (tropical weights are all 1) on something called a *skeleton*. They worked with a fixed skeleton, which is something obtained by taking an abstract

tropical curve and contracting some leaf vertices. If this contraction is done recursively for every leaf vertex, we obtain something called a *minimal skeleton* (in Figure 1.5 this would be the circle/hexagon of the tropical curve).

A tropicalization is *faithful* on a skeleton  $\Sigma$  if all the tropical weights are 1, meaning the lattice length between two points is the same as the metric length in the corresponding metric graph. With their fixed skeleton  $\Sigma$ , they define three piecewise-linear coordinate functions whose slopes everywhere have a GCD of 1 (so that there is never a common multiple in any direction vector). They use their lifting theorem to construct three rational functions on the original curve  $X$  (which give an embedding  $X \rightarrow \mathbf{P}^3$ ) such that the tropicalization of this image is described on  $\Sigma$ , by the piecewise-linear coordinate functions.

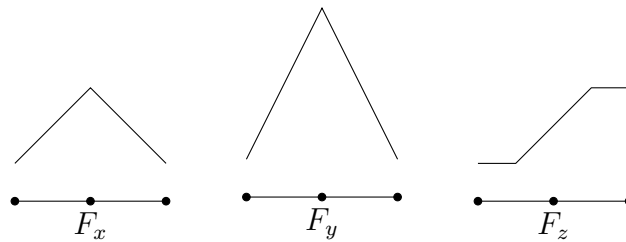

Figure 1.6: Baker-Rabinoff coordinate functions along a fixed edge.

This is a nice application of lifting divisors but it was only a part of the tropical picture. For the tropical curve to be balanced, it is necessary for there to be rays extending outwards from the skeleton to oppose the change in slopes of the coordinate functions. Due to the nature of their construction, the rays in the Baker-Rabinoff construction have a large tropical weight and so the lattice length metric does not agree with the abstract metric graph on these rays.

What Philipp Jell and I did (chapter 2), was to take a skeleton  $\Sigma$  again but now considering the rays needed for balancing, used slightly different coordinate functions so that when we add in these extra rays to form the so-called *extended skeleton*, the whole tropical curve is isometric to the extended skeleton. Meaning again, the slopes have GCD 1 everywhere so that all the tropical weights are 1. We call these tropicalizations *fully-faithful*.

### 1.1.1 Smooth tropicalizations

The combinatorial condition for a tropicalization to be *smooth* is that the primitive tangent vectors at each point  $x$  span a saturated lattice of rank  $\deg(x) - 1$ . A lattice  $L$  is *saturated* if whenever  $d \cdot v \in L$  and  $d \in \mathbf{Z}$ , then  $v \in L$ . Thus, if the maximal vertex degree is  $D$ , we need at least  $D - 1$  dimensions to get a smooth tropicalization. In particular, among all genus  $g$  curves which can have a maximal vertex degree of  $2g$ , the minimum is  $2g - 1$ . In section 2.6, we construct a smooth tropicalization in  $D + 2$  dimensions, so 3 more from the theoretical smallest.

## **1.2 Berkovich analytic spaces and constructing tropicalizations**

Let us now go over some of the component tools and techniques that go into “lifting divisors from metric graphs to curves.” First, there is a second description of skeleta coming from so-called “semistable models,” which we will now describe.

Suppose we have a curve  $X$  over a valued field like  $\mathbf{Q}_p$ . If the curve is defined by equations in  $\mathbf{Z}_p$ , then  $X$  is the generic fibre of a scheme  $\mathfrak{X} \rightarrow \mathrm{Spec}(\mathbf{Z}_p)$  defined by those same equations. The special fibre  $\mathfrak{X}_{\mathbf{F}_p}$  can also give us information about  $\mathfrak{X}$ . For this, we assume that  $X$  is smooth and proper. The scheme  $\mathfrak{X}$  is useful to our purposes if  $\mathfrak{X}_{\mathbf{F}_p}$  is reduced and the singularities are transverse intersections. We call  $\mathfrak{X}$  a *semistable model*.

If  $\mathfrak{X}$  is a semistable model, then the intersection graph of  $\mathfrak{X}_{\mathbf{F}_p}$  is a metric graph with vertices  $v_1, \dots, v_n$  corresponding to the irreducible components  $C_1, \dots, C_n$  of  $\mathfrak{X}_{\mathbf{F}_p}$ . We connect  $v_i$  and  $v_j$  by an edge of length  $d$  if the intersection of  $C_i$  and  $C_j$  admits local coordinates where the intersection is defined by  $xy = t$  with  $v_p(t) = d$ . It can be shown that the metric graph coming from these semistable models agrees (up to subdivision) with the metric graphs coming from tropicalizations [BPR13].

To  $X$ , we associate an analytic space called the *Berkovich space*,  $X^{\mathrm{an}}$ . This space is the limit of all tropicalizations of a curve [Pay09] and describes all the skeleta/tropicalizations

of  $X$ . In concrete terms, the Berkovich space can also be described as the space of pairs  $(x, |\cdot|)$  where  $x \in X$  and  $|\cdot|$  is a seminorm on  $\kappa(x)$  extending the p-adic norm or whatever non-Archimedean norm we have on our field. For the interested reader, Matt Baker has written a longer introduction to Berkovich spaces [Bak08a].

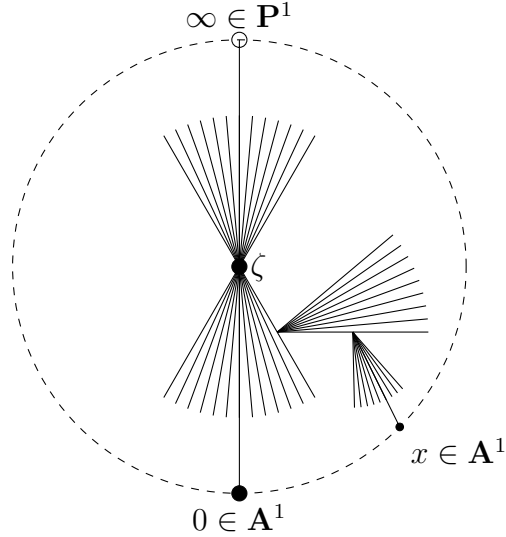

Figure 1.7: The Berkovich affine line (with the hole at  $\infty$  pictured).

**Example 1.2.1.** Given an algebraically closed, non-Archimedean field  $(K, |\cdot|)$ , we describe the Berkovich space  $\mathbf{A}_K^{1,\text{an}}$ . For the scheme  $\mathbf{A}_K^1$ , we are looking for seminorms on  $K(T)$  which extend  $|\cdot|$ .

There are a few types of seminorms which we can readily identify. First, for every closed point  $x \in K$ , we have the seminorm  $|f|_x = |f(x)|$ . Second, for every closed point and every  $r \in \mathbf{R}_{>0}$ , we have the seminorm  $|f|_{x,r} = \sup |f(y)|$ , with the supremum taken over the closed disc  $B(x, r)$ .

Note that due to the geometry of non-Archimedean norms, we have  $|\cdot|_{x,r} = |\cdot|_{y,r}$  if  $y$  is in the interior of  $B(x, r)$ . This gives our space paths, where to get from disc  $B(x, r)$  to disc  $B(y, s)$ , we increase the radius of our first disc from  $r$  to  $r'$  until it contains the second disc, then  $B(x, r') = B(y, r')$  and we can swap out  $x$  for  $y$  before shrinking the radius down to  $s$ .

The points we have identified are labeled, in the literature, Types I, II, and III. Where

Type I points are discs of radius 0 (closed points of  $\mathbf{A}^1$ ) and Types II and III are the discs where  $r$  is rational (belongs to the image of  $|\cdot|$ ) or irrational, respectively. There is a fourth type corresponding to certain limits of closed discs but these points are unimportant to our discussion.

We visualize  $\mathbf{A}^{1,\text{an}}$  by choosing some disc, commonly the Gauss point  $\zeta = |\cdot|_{0,1}$ , and putting it in the centre of the picture. Then, imagine putting the closed points around the centre “at-infinity.” Within the picture, we have an infinitely branching tree where at each Type II point, we get branches in every direction corresponding (non-canonically) to  $\mathbf{P}_K^1$ . The Type I points are leaves of this tree (Figure 1.7).  $\diamond$

As alluded to, the centre of the picture could be any Type II point. This is because a genus 0 graph doesn’t have a unique minimal skeleton in the same way that a genus 1 graph has a circle as its minimal skeleton.

**Example 1.2.2.** Suppose  $X$  is an elliptic curve such that  $\mathfrak{X}_{\mathbb{F}_p}$  is a nodal cubic,  $C$ . The skeleton of  $X$  has a single vertex corresponding to  $C$  plus a loop of some length. The whole Berkovich space looks like Figure 1.1 except at each point in the skeleton, there is branching like that in Figure 1.7. On the other hand, if we only take some branches, we can end up with a picture like in Figure 1.5.  $\diamond$

### 1.2.1 Faithful and fully-faithful tropicalization

Given a meromorphic function  $f$  on  $X^{\text{an}}$ , we can evaluate it at points of  $X^{\text{an}}$ , where if  $x \in X$  and  $|\cdot|$  is a seminorm on  $\kappa(x)$ , we consider the function  $(x, |\cdot|) \mapsto \log |f(x)|$ . It turns out that this is a piecewise-linear function with integral slopes. So the question is: which such piecewise-linear functions on a skeleton lift to a meromorphic function on  $X^{\text{an}}$ ?

So for our project of finding tropicalizations in 3 dimensions, the basic program is:

1. Write down the piecewise-linear coordinate functions for an ansatz embedding
2. Massage them slightly so that they lift.



3. Ensure that the new coordinate functions have the desired combinatorial properties (e.g. injective, GCD 1).

### 1.3 Tropical multiplicities

A related question to divisors is that of multiplicities. Given a polynomial in  $\mathbb{C}[x]$ , we understand how to consider the multiplicity of a given zero. In terms of tropical polynomials, these multiplicities are commonly understood through some combinatorics.

Over  $\mathbb{C}$ , a polynomial  $a_0 + a_1x + \dots + a_nx^n$  will factor into a product of linear forms:  $a_n(x - \lambda_1)^{\nu_1} \dots (x - \lambda_k)^{\nu_k}$ . In tropical (min/plus) arithmetic, this factorization looks like  $\min\{A_i + ix\} = \sum \nu_i \min\{x, \Lambda_i\}$  (as functions). Combinatorially, the multiplicities  $\nu_i$  are the horizontal lengths of the edges of slope  $-\Lambda_i$  in the extended Newton polygon.

**Example 1.3.1.** One can verify (e.g. graphically) that  $\min\{3x, x + 2, 4\} = 2 \min\{x, 1\} + \min\{x, 2\}$ . The extended Newton polygon is drawn in Figure 1.8.  $\diamond$

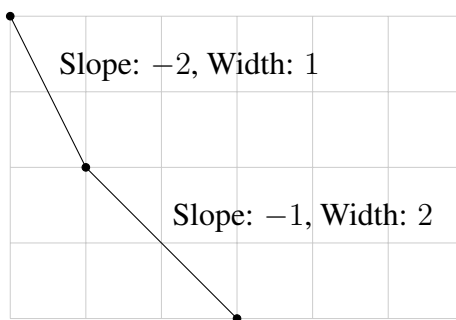

Figure 1.8: Newton polygon for  $\min\{3x, x + 2, 4\}$

### 1.4 The Descartes' Problem

Descartes' rule gives a bound on the number of positive roots of a real polynomial. If all the roots are real, this upper bound is sharp. For example, take the polynomial  $1 - 3x - 2x^2 + x^5$ , Descartes' rule says take the signs of the coefficients, ignoring zeroes, and look at the number of times the sign changes. Here that sequence is  $+, -, -, +$  and it changes once from  $+$  to

– and then a second time from – to +. Two sign changes mean at most two positive real roots. If we change  $x$  to  $-x$  we find exactly one sign change and hence there is at most one negative root. One can think about these numbers  $2(+)$  +  $1(-)$  as divisor over signs just like how polynomials over valued fields have divisors over the tropical numbers (the edge lengths).

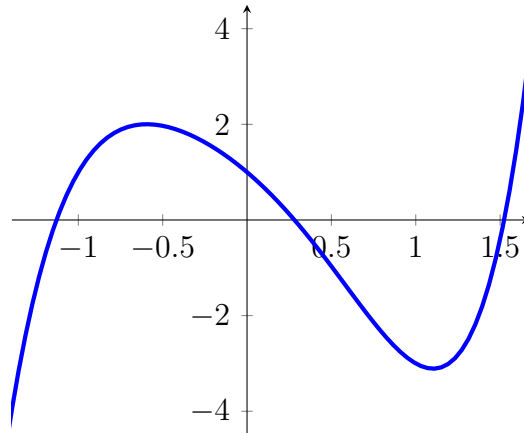

Figure 1.9: Graph of  $y = 1 - 3x - 2x^2 + x^5$  showing one negative and two positive zeroes.

In multiple variables, there is a theory of tropical intersections (e.g. [JY16]) which extends the classical Bernstein-Khovanskii-Kushnirenko (BKK) bound. The BKK bound says that the maximal number of roots in  $(\mathbb{C}^*)^n$  to a system of Laurent polynomials is bounded by a combinatorial quantity known as a “mixed-volume.”

On the other hand, there is no complete multivariate Descartes’ rule of signs. A summary of previous work on this problem is described in more detail in the introduction of chapter 4. For now, let us describe one influential paper of Itenberg and Roy [IR96].

#### 1.4.1 Itenberg and Roy’s theorem and conjecture

Viro’s patchworking [Vir89] gives a way to construct real hypersurfaces with a given topology. These ideas were later extended by Sturmfels [Stu94b] for complete intersections. Itenberg and Roy analyzed this patchworking method to construct systems of equations with as many positive roots as they could (more generally: the roots in any orthant). These

combinatorial numbers  $N$  are a bit technical so we omit a definition. They have something to do with various ranks and coranks of matrices associated to the vectors of mixed cells.

So given a collection of polynomials  $f_1, \dots, f_n$  with undetermined coefficients but prescribed signs, Itenberg and Roy construct, via patchworking, an instance of the system with  $N$  positive roots. Therefore  $N$  is a lower bound on any possible upper bound (i.e. on any potential Descartes' formula). They conjectured that their lower bound was sharp, but Li and Wang later gave a counterexample [LW98] to this.

#### 1.4.2 Mixed sparse resultants

With Andreas Gross, we were able to recover Itenberg and Roy's lower bound using properties of resultants rather than patchworking. Given a collection of polynomials with undetermined (variable) coefficients, the (mixed sparse) resultant is a polynomial in those coefficient variables which is zero if and only if the polynomials have a common zero. By setting one of the polynomials to be the line  $u_0x_0 + \dots + u_nx_n$ , the resultant is now a polynomial in  $u_0, \dots, u_n$  which, if you fix values for the other coefficients, is proportional to the product

$$\prod_{p \in V} (p_0u_0 + \dots + p_nu_n).$$

Here  $V$  is the set of common zeroes (with multiplicity).

In the counterexample of Li and Wang, the signs of the resultant are given in Figure 1.10. Some signs of the resultant are determined, while others could be either positive or negative depending on the absolute value of the input coefficients. Nonetheless, even though some signs cannot be determined, if we look at the boundary of this resultant (by setting one variable to 0), we get some univariate polynomials to which Descartes' rule applies. The signs on the boundary constrain us to a maximum of 3 positive roots—the correct upper bound!

```

*
+ *
+ + *
* * * *
+ * + * *
+ - * * - *
+ - + * + - *

```

Figure 1.10: A multiple of the signed sparse resultant in the Li-Wang example. A \* means the sign is undetermined.

## 1.5 Hyperfields and Baker-Lorscheid multiplicities

What Baker and Lorscheid observed, is that for univariate polynomials, both Descartes’ rule of signs and tropical multiplicities can be described algebraically in addition to their combinatorial definitions [BL21a]. This algebraic multiplicity is computed through factoring polynomials over *hyperfields*, which one can think of as fields but where addition may be a set of one or more elements. Hyperfields arise naturally when we have a field and we want to identify elements of a similar type (e.g. same sign or same valuation).

### 1.5.1 The sign hyperfield

Consider the set  $S = \{0, 1, -1\}$  with elements representing zero, a positive number, and a negative number. The arithmetic on  $S$  consists of rules like:  $(-1) \cdot (-1) = 1$ , which means “the product of a negative number and another negative number is positive.” Or:  $(-1) \boxplus 1 = \{0, 1, -1\}$ , meaning “the sum of a negative and a positive number can be any kind of number.” In this arithmetic, a product of polynomials may be a set of polynomials, e.g.

$$(x - 1)(x + 1) = x^2 - x + x - 1 = x^2 + \{0, 1, -1\}x - 1.$$

In adding  $-x$  and  $x$  we can get either  $0, x$  or  $-x$ . As a convenient shorthand, rather than writing this product as a big set, we sometimes write sets for coefficients if they are undetermined and leave the determined coefficients as they are.

In this arithmetic, quotients are no longer unique. Therefore, instead of asking for “how many times does  $(x - 1)$  go into  $f$ ?” we ask for the maximum number of times. In this arithmetic, Baker and Lorscheid’s result [BL21a, Theorem C] is that Descartes’ combinatorial rule is equal to this algebraic multiplicity of the maximum number of factorizations.

### 1.5.2 The tropical hyperfield

We have a way of talking about tropical functions (as functions), but to do algebra, we are going to want a way to talk about them as polynomials. For instance, we know that  $\min\{1\} = \min\{1, 1\}$  but tropically these are quite different as only in the second one is the minimum achieved twice! Enter the *tropical hyperfield*. Let  $\mathbf{T} = \mathbf{R} \cup \{\infty\}$  and define  $a \cdot_{\mathbf{T}} b = a +_{\mathbf{R}} b$  (with usual rules for adding infinity). For tropical addition, we have a set-valued operation where if we let  $a_0 = \min\{a_1, \dots, a_n\}$ , then

$$\bigsqcup_{i=1}^n a_i = \begin{cases} \{a_0\} & \text{if the minimum is not achieved twice,} \\ [a_0, \infty] & \text{if it is.} \end{cases}$$

We also identify elements with singleton sets and flatten repeated additions (i.e. we treat addition using the powerset monad). For the tropical hyperfield, the combinatorial multiplicities defined earlier, are equal to the algebraic multiplicity [BL21a, Theorem D].

## 1.6 Tropical extensions

In chapter 3, I describe, among other things, a different proof of Baker and Lorscheid’s factorization result for  $\mathbf{T}[x]$ . This proof extends to a more general setting called *tropical extensions*. A tropical extension of a hyperfield is analogous to extending a field  $K$  to a valued field of series over  $K$  such as Laurent series  $K((t))$  or Puiseux series  $K\{\{t\}\}$ .

In chapter 3, I show that knowing how to factorize over  $H$ , implies we know how to factorize over any tropical extension of an ordered group  $\Gamma$  by  $H$ . More concretely, if  $f$  is a

polynomial over the extension  $H \rtimes \Gamma$ , then it will have various initial forms  $\text{in}_w f \in H[x]$ . I show that factorizations of  $\text{in}_w f$  lift. It is an easier result to show that if  $f$  factors then so does  $\text{in}_w f$ . Thus, we know (for univariate polynomials) that multiplicities of  $f$  are equal to multiplicities of  $\text{in}_w f$  for an appropriate  $w$ .

For instance,  $\mathbf{T}$  is an extension of  $\mathbf{R}$  by the Boolean/Krasner hyperfield,  $\mathbf{K} = \{0, 1\}$ . The Krasner hyperfield is the hyperfield which arises from identifying all non-zero elements of a field together and calling this “1.” In  $\mathbf{K}$ , we can factor out  $(x + 1)$  a maximum of  $d$  times from any polynomial of the form  $x^m + \dots + x^{m+d}$ . As an example of what this says, if we have a polynomial in  $\mathbf{C}[x]$  whose support is  $\{m, \dots, m + d\}$ , then that polynomial will have exactly  $d$  non-zero roots.

Applying my result to  $\mathbf{T}[x]$ , if  $f$  has an edge in its Newton polygon of slope  $-\Lambda_i$ , then  $\in_{\Lambda_i} f$  will be something like  $x^m + \dots + x^{m+\nu_i}$ , which has a multiplicity in  $\mathbf{K}$  of  $\nu_i$ . Since factorizations lift, we can conclude that  $\Lambda_i$  has multiplicity  $\nu_i$ .

My result also applies to extensions by  $\mathbf{S}$ , for instance to the *tropical real hyperfield* which sees application in real tropical geometry (e.g. [JSY22]). An important corollary is that all of these tropical extensions (by  $\mathbf{K}$  or  $\mathbf{S}$ ) satisfy the *degree bound*: the sum of multiplicities of a polynomial is bounded by its degree. In the hyperfield literature, these extensions are exactly the *stringent* hyperfields [BS21], meaning that  $x \boxplus y$  is always either a singleton or contains 0.

In chapter 3 we work with a more general class of algebras called *idylls*. This is largely for the convenience of being able to talk about polynomial rings as part of the category.<sup>1</sup> However, it is also nice to know the broadest natural context in which Baker-Lorscheid multiplicities can be defined. Some notes about factorization algorithms that appear in the literature are presented in Appendix A.

---

<sup>1</sup>Multiplication of polynomials over hyperfields also becomes set-valued but hyperrings must have single-valued products.

### 1.6.1 Relative multiplicities

As mentioned already, most common hyperfields are quotients of fields. For instance, we can take a valued field and identify elements which have the same valuation or we can take a real field and identify elements which have the same sign. These identifications give maps to hyperfields like  $\mathbf{T}$  and  $\mathbf{S}$  and one can ask about *relative multiplicities*. For example, given a polynomial in  $\mathbf{R}$ , we can talk about its image in  $\mathbf{S}$  and ask for the multiplicity of  $(x - 1)$  in  $\mathbf{S}[x]$ . This gives an upper bound on the number of positive roots in  $\mathbf{R}[x]$  which is exact if all the roots are real. Likewise, if  $K$  is an algebraically-closed valued field, the relative multiplicity of  $\gamma \in \mathbf{T}$  is exactly the number of roots in  $K[x]$  with valuation  $\gamma$ .

As with the relationship between divisors on curves and those on metric graphs, here we are relating multiplicities in a field with those in a hyperfield.

## **1.7 Multivariate multiplicities**

There are two directions one can go in to generalize multiplicities to multivariate polynomials. The first, is to consider the multiplicity of a linear factor. This is the most direct generalization of the univariate multiplicity and avoids complications like having resultants with some but not all of the signs being determined (Figure 1.10).

We also define some multiplicity operators related to the geometric picture. For instance, suppose we are given a polynomial with just the signs. Then the Newton polytope is going to have signs at each lattice point but it won't have a subdivision we can exploit. But if we do have a subdivision to exploit—or if we can impose one—then there is more we can say. This leads to two similar multiplicity operators (one where we have subdivisions and one where we impose subdivisions).

**Example 1.7.1.** In Figure 1.11, we have a degree 5 polynomial with given signs. If we want to compute the multiplicity of  $(x + y + z)$ , we might try to impose a (mixed) subdivision in which we have a triangle with all  $+$ 's or all  $-$ 's on the vertices. If the mixed subdivision is

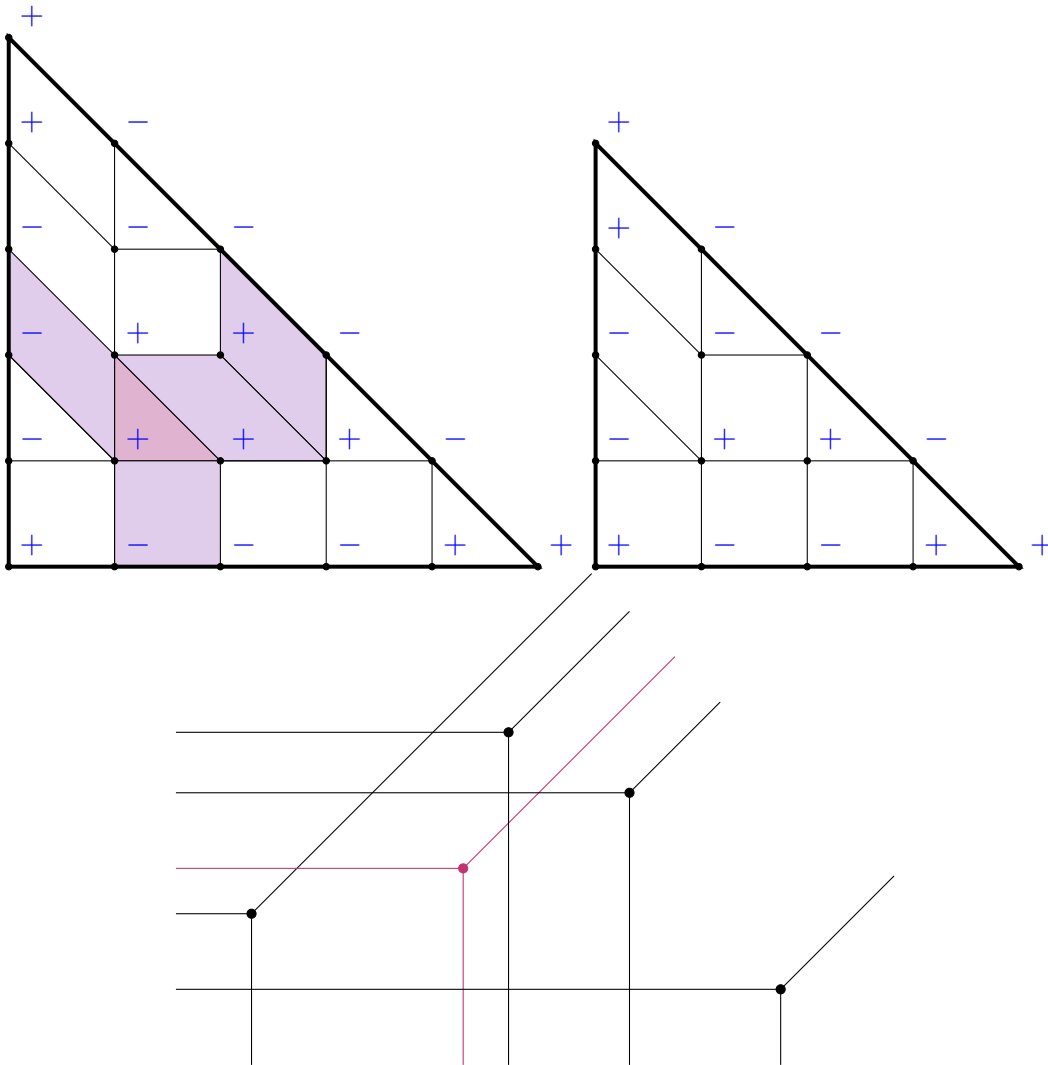

Figure 1.11: Sign compatible subdivision, quotient with induced subdivision, and associated dual arrangement.



compatible with the signs, then we can find a quotient by glueing together the strip of mixed cells corresponding to intersections with the tropical line which is dual to our triangle.

For the standard multiplicity, we just factor out  $(x + y + z)$  as many times as we can. Here, we also repeatedly factor out  $(x + y + z)$ , but we keep the subdivision we imposed on the problem. This gives us a lower bound on the hyperfield multiplicity: the maximum number of all  $+$  or all  $-$  triangles among all sign-compatible mixed subdivisions.  $\diamond$

### 1.7.1 Morphisms and multiplicities

An important lemma which we exploit numerous times, is that morphisms (of hyperfields) preserve factorizations. For instance, the morphism  $\mathbf{R} \rightarrow \mathbf{S}$ , or from a valued field to  $\mathbf{T}$ . With regards to relative multiplicities, this means that the maximum number of times we can factor out  $(x - 1) \in \mathbf{S}[x]$  is at least as much as the number of times we can factor out a positive root in  $\mathbf{R}[x]$ .

This lemma can be extended to initial forms which are composed from a morphism of hyperfields and a morphism of polynomial rings (multiplying a polynomial by a unit). These polynomial ring maps are described more categorically in chapter 3 than in chapter 4, but the conclusion is the same: taking initial forms gives an upper bound on multiplicities, which is exact in the univariate case (chapter 3).

**Example 1.7.2.** Let  $a, b, r, s, t$  be positive real numbers and let

$$\begin{aligned} f &= 1 + ax - bx = 0, \\ g &= 1 + rx^3 - sy^3 - tx^3y^3 = 0. \end{aligned}$$

Since we have a morphism  $\mathbf{R} \rightarrow \mathbf{S}$ , we know that multiplicities in  $\mathbf{S}$  bound the number of positive common roots of  $f$  and  $g$ .

If we take the resultant of  $f, g$  and  $l := 1 + ux + vy$ , we get a polynomial in  $u, v$  whose signs are pictured in Figure 1.10. Then, we set  $v = 0$  to get a set of univariate polynomials

in  $u$ :

$$1 - u + u^2 \pm u^3 + u^4 - u^5 \pm u^6. \quad (1.2)$$

This is the bottom row from the picture. We could consider the other edges of the triangle in the picture, but the minimum occurs for the bottom row (the boundary multiplicity).

Observe that for any choice of signs we make for  $u^3$  and  $u^6$  in (1.2), the maximum number of times we can factor out  $(1 + u)$  is bounded by 3. It follows, therefore, that the maximal number of times we can factor out  $(1 + u + v)$  from any choice of signs for the resultant, is also bounded by 3.

So to summarize:

(relative multiplicity = maximum number of positive common roots to  $f, g$ )

$\leq$

(hyperfield multiplicity = maximum number of times we can factor out  $1 + ux + vy$ )

$\leq$

(boundary multiplicity = maximum number of times we can factor out  $1 + ux$ ) = 3

And in this example, Li and Wang gave a specific choice of  $a, b, r, s, t$  where we do have 3 positive common roots [LW98]. Hence we have equalities above.  $\diamond$

# **Part I**

## **Divisors on Metric Graphs**

**CHAPTER 2**

**CONSTRUCTION OF FULLY FAITHFUL TROPICALIZATIONS FOR CURVES**

**IN AMBIENT DIMENSION 3**

*Joint work with Philipp Jell.*

Classically, it is well-known that while not every algebraic curve is a plane curve, every curve is a space curve. That is, every curve admits a closed embedding into  $\mathbf{P}^3$  (see for instance [Har77, Corollary IV.3.6]). Similarly, every graph has an embedding in  $\mathbf{R}^3$ . In fact, this can be done with straight lines by putting the vertices as points on the twisted cubic. Since no plane intersects the twisted cubic in 4 points, no pair of chords on the twisted cubic can cross.

In this chapter, we study the following question, which might be seen as a tropical combination of these two facts.

**Question.** *Let  $X$  be a Mumford curve over a non-Archimedean field. Does there exist a map of  $X$  to a three-dimensional toric variety such that the associated tropicalization is fully faithful?*

We answer this question positively, with toric variety being  $(\mathbf{P}^1)^3$ .

### 2.0.1 Fully and totally faithful tropicalizations

Let us explain the analogy. Let  $Y$  be a toric variety and  $X$  an algebraic curve. Both  $X$  and  $Y$  have associated Berkovich spaces  $X^{\text{an}}$  and  $Y^{\text{an}}$ . The toric variety  $Y$  has a canonical tropicalization  $\text{Trop}(Y)$  which is a partial compactification of  $\mathbf{R}^{\dim Y}$  and comes with a non-constant map  $\text{trop}_Y: Y^{\text{an}} \rightarrow \text{Trop}(Y)$ . For a map from  $\varphi: X \rightarrow Y$  we denote by  $\text{Trop}_\varphi(X)$  the image of the composition  $\text{trop}_\varphi := \text{trop}_Y \circ \varphi^{\text{an}}: X^{\text{an}} \rightarrow \text{Trop}(Y)$ . We call

the space  $\text{Trop}_\varphi(X^{\text{an}})$  an *embedded tropical curve*. It is canonically equipped with the structure of a metric graph (potentially with edges of infinite length).

Also associated with  $\varphi$  is another metric graph with potentially infinite edges: the so-called completed extended skeleton  $\Sigma = \Sigma(\varphi)$ , which is a metric subgraph of  $X^{\text{an}}$ . It was shown by Baker, Payne and Rabinoff [BPR16] that  $\text{Trop}(X) = \text{trop}_\varphi(\Sigma)$  and that  $\text{trop}_\varphi|_\Sigma: \Sigma \rightarrow \text{Trop}(X)$  is a piecewise-linear, integral affine map of metric graphs. The tropicalization is called *fully faithful* if this map is an isometry. In particular, a fully faithful tropicalization admits a section  $\text{Trop}_\varphi(X) \rightarrow X^{\text{an}}$ . We can slightly relax those conditions: A tropicalization is called *totally faithful* if the map is an isometry when removing the vertices of  $\Sigma$  that are infinitely far away.

We prove the following theorem (Theorem 2.5.4) and a corollary (Theorem 2.5.1) that is proved along the way.

**Theorem 2.A.** *Let  $X$  be a smooth projective Mumford curve. Then there exist three rational functions  $f_1, f_2, f_3$  on  $X$  such that the tropicalization associated to the map  $X \rightarrow (\mathbf{P}^1)^3, x \mapsto (f_1, f_2, f_3)$  is fully faithful.*

**Corollary.** *Let  $Y$  be a proper toric variety of dimension three. Then there exists a morphism  $\varphi: X \rightarrow Y$  such that the induced tropicalization is totally faithful.*

Our construction starts with three piecewise-linear functions on a skeleton of  $X^{\text{an}}$  that were chosen to have the correct combinatorial properties and then tweaked so that we could lift those piecewise-linear functions to rational functions on  $X$ . The choice of these piecewise linear functions was inspired by Baker’s and Rabinoff’s construction [BR15, Section 8]. Here, Baker and Rabinoff construct a faithful tropicalization for any curve in ambient dimension 3. Since they only consider faithful tropicalizations, they get to fix a skeleton beforehand (as opposed to a complete extended skeleton) and then construct an embedding that maps that skeleton isometrically onto its image (as opposed to our situation, where the completed extended skeleton depends on the embedding). This means that Baker

and Rabinoff get much more freedom when picking their functions and only require a weaker lifting theorem.

Our main tool is a lifting theorem (Theorem 2.2.1) of the second author [Jel20], that allows us to lift tropical meromorphic functions on a skeleton to the algebraic curve  $X$ . This theorem refines another lifting theorem of Baker and Rabinoff [BR15].

Similar questions to ours have been considered. For example in the works of Cartwright, Dudzik, Manjunath, and Yao [Car+16] and Cheung, Fantini, Park, and Ulirsch [Che+16]. However, these results are a bit different in spirit, as the authors start with a given skeleton and then make a construction that works for *some* algebraic curve with that skeleton. We also only care about the skeleton of the curve in our construction, but the map we construct works for *every* curve with that skeleton.

While the main body of our text deals with general Mumford curves, i.e. we do not use any additional properties, our main technique of lifting tropical meromorphic functions can also be used to construct nice tropicalizations for all curves with a given explicit skeleton. We exhibit this in section 2.7 for a special skeleton of genus 2.

## 2.0.2 Smooth tropicalizations

We consider another property of tropicalizations: smoothness. Roughly speaking, an embedded tropical curve is smooth if locally, at every vertex, the tropical curve looks like the 1-dimensional fan in  $\mathbf{R}^k$  whose rays are  $e_1, \dots, e_k, -\sum e_i$ .

We define in Definition 2.6.1 an invariant of an embedded tropical curve that measures how singular that tropical curve is. We prove the following resolution of singularities result (Corollary 2.6.3) by showing that we can inductively lower this invariant via re-embedding.

**Theorem 2.B.** *Let  $X$  be a Mumford curve and  $\varphi: X \rightarrow Y$  a map that induces a fully faithful tropicalization of  $X$ . Then there exist functions  $f_1, \dots, f_n$  on  $X$  such that  $\varphi' := \varphi \times (f_1, \dots, f_n): X \rightarrow Y \times (\mathbf{P}^1)^n$  induces a fully faithful tropicalization of  $X$  and such that  $\text{Trop}_{\varphi'}(X)$  is a smooth tropical curve.*

In Theorem 2.6.2, we prove a resolution procedure for singularities of embedded tropical curves. We use this to show that any smooth algebraic curves admits a map to  $(\mathbf{P}^1)^{2g+2}$  that results in a smooth tropicalization (Corollary 2.6.5). The best possible bound on the dimension of the ambient space needed is  $2g - 1$ , since any curve whose minimal skeleton has a vertex of degree  $d$  cannot be embedded smoothly into a space of dimension  $2d - 2$  (or smaller). We are hence three off of the optimal bound.

### 2.0.3 Structure

In section 2.1, we recall the necessary background on tropicalization, Berkovich skeleta and (tropical) meromorphic functions.

In section 2.2 we construct three tropical meromorphic functions on the skeleton, depending on certain parameters, and we show that these functions are liftable.

In section 2.3 we describe conditions on those parameters that will allow us to prove Theorem 2.A.

In section 2.4 we show that if our parameters meet the conditions stated in section 2.3, the map induced by the lifts of the functions from section 2.2 induces a totally faithful tropicalization.

In section 2.5 we complete the proof of Theorem 2.A by showing that the conditions in section 2.3 can always be met, and we show that tropicalizations is indeed already fully faithful.

In section 2.6 we prove Theorem 2.B via a resolution procedure for embedded tropical curves.

In section 2.7 we exhibit our lifting techniques on a more specific example of a genus 2 skeleton.

## 2.0.4 Acknowledgements

The authors would like to thank Joe Rabinoff for fruitful discussions and Matt Baker and Walter Gubler for comments on a preliminary draft.

## 2.1 Preliminaries

Throughout this chapter,  $K$  will denote an algebraically closed field which is complete with respect to a non-trivial, non-Archimedean absolute value  $|\cdot|_K$ . We denote the value group of  $K$  by  $\Lambda := \log |K^\times| \subseteq \mathbf{R}$ .

### 2.1.1 Tropicalization of curves in $\mathbf{P}^n$

Most of our work in this chapter is concerned with tropicalizing curves in products of projective spaces. This is a special case of the more general theory of tropicalizing toric varieties as described in Payne's article [Pay09]. Although some results in this chapter are phrased in the more general language of toric varieties, it is sufficient for the reader to picture products of projective spaces.

**Definition 2.1.1.** The *tropical projective space*  $\mathbf{TP}^n$  is the quotient of

$$(\mathbf{R} \cup \{-\infty\})^{n+1} \setminus \{(-\infty, \dots, -\infty)\}$$

under the following  $\mathbf{R}$ -action:

$$\lambda \cdot (a_0, \dots, a_n) = (a_0 + \lambda, \dots, a_n + \lambda).$$

We define a map  $\text{Log}: \mathbf{P}_K^n \rightarrow \mathbf{TP}^n$  by

$$\text{Log}([x_0 : \dots : x_n]) = [\log |x_0|_K : \dots : \log |x_n|_K]$$



with the convention that  $\log(0) = -\infty$ .

**Definition 2.1.2.** When  $X$  is a projective variety over  $K$  that intersects the torus,  $(K^\times)^n$ , its *tropicalization* is the closure (in the Euclidean topology) of the image of  $X$  under  $\text{Log}$ . We denote the tropicalization of  $X$  by  $\text{Trop}(X)$ .

### 2.1.2 Limits in $\mathbf{TP}^n$

Let us look at the simple case of a tropical curve in  $\mathbf{TP}^2$ . This is a piecewise-linear simplicial complex with some set of extreme rays. Those extreme rays will have a limit point on one of the boundary strata of  $\mathbf{TP}^2$  which we will now describe.

Let  $R = \{[0 : a + tu : b + tv] : t \geq 0\}$  be a ray in the affine plane,  $\text{Trop}(K^2)$ . Let  $\lim R := \lim_{t \rightarrow \infty} [0 : a + tu : b + tv]$  denote the limit point of this ray.

Case 1. If  $u < 0$  and  $v < 0$  then  $\lim R = [0 : -\infty : -\infty]$ .

Case 2. If  $u = 0$  and  $v < 0$  then  $\lim[0 : a : b + tv] = [0 : a : -\infty]$ . Similarly if  $v = 0$  and  $u < 0$ .

Case 3. If  $0 \leq u < v$  then  $[0 : a + tu + b + tv] = [-tv : a + t(u - v) : b]$  and  $\lim R = [-\infty : -\infty : 0]$ . Similarly if  $0 \leq v < u$ .

Case 4. If  $0 < u = v$  then  $[0 : a + tu : b + tu] = [-tu : a : b]$  and  $\lim R = [-\infty : a : b]$ .

So if  $v < u = 0$  or  $u < v = 0$  or  $0 < u = v$  then the boundary stratum is 1-dimensional. Otherwise, the boundary stratum is just a single point. Figure 2.1 illustrates this. For general  $n$ , the boundary strata of  $\mathbf{TP}^n$  forms a simplex.

We will see in section 2.4 that this boundary strata does not have enough components to separate all of our extreme rays. Instead, we will work with  $(\mathbf{TP}^1)^3$ .

For  $\mathbf{TP}^1$ , Definition 2.1.1 is equivalent to the set  $\mathbf{R} \cup \{\pm\infty\}$ . The boundary strata of  $(\mathbf{TP}^1)^n$  can be pictured as the  $(n - 1)$ -skeleton of an  $n$ -dimensional cube. For instance, in  $(\mathbf{TP}^1)^3$ , parallel rays in the directions  $\pm(0, 0, 1)$ ,  $\pm(0, 1, 0)$ ,  $\pm(1, 0, 0)$  have distinct limits.

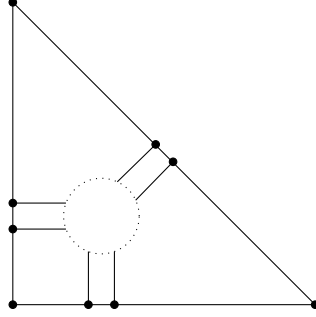

Figure 2.1: Boundary strata of  $\mathbf{TP}^2$ . Parallel rays in the directions  $(-1, 0)$ ,  $(0, -1)$  or  $(1, 1)$  intersect the boundary in distinct points. Rays in any other direction intersect the closest corner.

### 2.1.3 Metric graphs

Let  $\Gamma$  be a topological space with a distance function  $d: \Gamma \times \Gamma \rightarrow \mathbf{R} \cup \{\infty\}$ . We call  $\Gamma$  a *metric graph* if it admits a 1-dimensional simplicial structure where every edge  $e$  (aka 1-simplex), with the induced distance function  $d_e$  is isometric to a closed interval:  $[0, l] \subseteq \mathbf{R} \cup \{\infty\}$ . We allow the possibility of infinite edges—*isometric to  $[0, \infty]$* —but we require that these infinite edges be leaf edges.

Explicitly, there exists a set of vertices  $V$  and set of edges  $E$ . Every edge  $e$  has a distance function  $d_e$ , such that  $e$  is isometric to a closed interval. Finally, there are maps  $\partial e \rightarrow V$  that tell us how to glue the edges to the vertices. Every edge of  $\Gamma$  has the usual distance function which we extend to  $\Gamma$  by setting  $d(x, y) =$  the length of the shortest path from  $x$  to  $y$ .

A choice of  $G = (V, E)$  is called a *graph model* of  $\Gamma$ . We forget about all the distance functions and topologies on  $E$  and just remember the lengths. In this way,  $G$  is a graph where each edge  $e \cong [0, l]$  has an associated length  $l$ . If  $G$  is a graph model of  $\Gamma$ , then so is any length-respecting subdivision of  $G$ . When the graph model is fixed, we may refer to edges and vertices of  $G$  as edges and vertices of  $\Gamma$ .

*Note.* Usually one would call  $G$  a “weighted graph” but since the term “weight” is used in relation to the tropical balancing condition, we avoid this here.

Given a subgroup  $\Lambda \subseteq \mathbf{R}$  (e.g. the value group of  $K$ ), we say that  $\Gamma$  is a  $\Lambda$ -*metric graph*

if it admits a graph model  $G = (V, E)$  where the weight of every finite edge of  $G$  belongs to  $\Lambda$ .

Given a graph model  $G = (V, E)$  for  $\Gamma$ , the  $\Lambda$ -rational points of  $\Gamma$  are the points whose distance to some (and hence every) vertex is an element of  $\Lambda$ — we call this set  $\Gamma(\Lambda)$ .

See Section 2.1 of [Ami+15] for another description of a metric graph.

We recall that a *spanning tree* of a (connected) graph is a maximal, acyclic collection of edges such that every vertex of the graph is an endpoint of one of these edges. If  $e_1, \dots, e_g$  form the complement of such a spanning tree, then  $g$ —which is well defined—is called the *genus* of  $G$ . One can check that if  $G$  is a graph model of  $\Gamma$  then  $g = \dim_{\mathbf{Q}} H_1(\Gamma; \mathbf{Q})$ .

#### 2.1.4 Berkovich analytic spaces

For every variety  $X$  over  $K$ , there is a topological space,  $X^{\text{an}}$ , introduced by Berkovich [Ber90] called the *Berkovich analytification*. The points of  $X^{\text{an}}$  are pairs  $(p_x, |\cdot|_x)$  where  $p_x \in X$  and  $|\cdot|_x$  is an absolute value on the residue field  $k(p_x)$  at the point  $p_x$  extending the absolute value of  $K$ . The topology on  $X^{\text{an}}$  is the weakest topology making the canonical map  $X^{\text{an}} \rightarrow X$  continuous and, for every open set  $U$  of  $X$  and section  $f \in \mathcal{O}_X(U)^\times$ , the map  $U^{\text{an}} \rightarrow \mathbf{R}$  given by

$$(p_x, |\cdot|_x) \mapsto |f(x)| := |f(p_x)|_x$$

is continuous.

#### *Classification of points*

When  $X$  is a curve, the points of  $X^{\text{an}}$  can be classified into four types.

If  $p_x$  is a closed point of  $X$ , then  $k(p_x) = K$  and  $|\cdot|_x = |\cdot|_K$  is the only absolute value we can take. In this way, we view  $X(K)$  as a canonical subset of  $X^{\text{an}}$ . Points in  $X(K)$  are called type I points of  $X^{\text{an}}$ .

If  $p_x$  is the generic point of  $X$  and  $\mathcal{H}(x)$  is the completion of  $k(p_x)$  with respect to  $|\cdot|_x$ . Then we say  $(p_x, |\cdot|_x)$  is a type II point if  $\text{trdeg}(\widetilde{\mathcal{H}}(x)/\widetilde{K}) = 1$  where  $\widetilde{\cdot}$  denotes the residue

field.

The terminology of type I and type II points is due to Thuiller [Thu05] following Berkovich's original classification [Ber90]. There is also a notion of type III and IV points (*loc. cit.*) which we do not make use of in this chapter.

### 2.1.5 Skeleta and extended skeleta of curves

When  $X$  is a curve, there exists a distinguished set  $\Gamma \subset X^{\text{an}}$  called a *skeleton of  $X$*  (or of  $X^{\text{an}}$ ) with the following key properties.

1. A skeleton is a metric graph.
2. There is a strong deformation retract  $\tau: X^{\text{an}} \rightarrow \Gamma$ .
3. The map  $\tau_*: \text{Div}(X) \rightarrow \text{Div}_\Lambda(\Gamma)$  is surjective and takes principal divisors to principal divisors. We define the divisor group of  $\Gamma$  in subsection 2.1.8.

We start by defining skeletons for open discs and open annuli. More detail is given in [BPR13, Section 2].

**Definition 2.1.3.** Let  $\mathbf{A}^{1,\text{an}} = (\text{Spec } K[T])^{\text{an}}$ . We call the sets

$$B(r) := \{x \in \mathbf{A}^{1,\text{an}} : |T|_x < r\} \text{ and } A(r, s) := \{x \in \mathbf{A}^{1,\text{an}} : r < \log |T|_x < s\}$$

*open discs* and *open annuli* respectively. They are parameterized by real numbers  $r, s$  which we call *logarithmic radii*. For an open annulus, we also allow  $r = -\infty$  in which case  $A(-\infty, s)$  is a *punctured disc*.

The disc  $B(t)$  has a distinguished element  $\rho_{B(t)}$  defined by

$$\left| \sum a_i T^i \right|_{\rho_{B(t)}} = \max_i |a_i| t^i.$$

As the disc  $B(r)$  expands to  $B(s)$  in the annulus, we take distinguished elements to form the set

$$\Sigma(A(r, s)) := \{\rho_{B(t)} : r < \log t < s\}.$$

This is called the *skeleton* of  $A(r, s)$ .

The annulus  $A(r, s)$  canonically retracts onto  $\Sigma(A(r, s))$  via

$$\tau: |\cdot|_x \longmapsto \rho_{B(\log |T|_x)}.$$

Berkovich showed that this is a strong deformation retraction [Ber90, Proposition 4.1.6].

**Definition 2.1.4.** For a smooth, projective curve  $X/K$ , a *semistable vertex set*  $V$  of  $X$  is a finite set of type II points in  $X^{\text{an}}$  such that  $X^{\text{an}} \setminus V$  is (isomorphic to) a disjoint union of finitely many open annuli and infinitely many open discs. Semistable vertex sets always exist [BPR13, Proposition 4.22]. If  $\chi(X) \leq 0$ , then a unique minimal skeleton exists [*loc. cit.*, Corollary 4.23].

Given a semistable vertex set  $V$  of  $X$ , the associated (finite) *skeleton* is

$$\Sigma(V) := V \bigcup \Sigma(A)$$

where the union is over the finite set of open annuli of  $X^{\text{an}} \setminus V$ . There is a canonical retraction  $\tau_V: X^{\text{an}} \rightarrow \Sigma(V)$  which is, in fact, a strong deformation retraction.

$\Sigma(V)$  is a  $\Lambda$ -rational metric graph with a canonical graph model  $(V, E)$ . The edges of  $\Sigma(V)$  are  $\Sigma(A)$  for each open annulus  $A$ . The length of the edge  $\Sigma(A)$  is the length  $s - r$  defined in Definition 2.1.3.

### *Completed skeleta*

A *completed semistable vertex set* is defined the same as a semistable vertex set except we also allow ourselves to include some points of type I. These type I points are infinitely far

away from the finite skeleton. If  $V$  is a completed semistable vertex set, then the set of type II points in  $V$  form a semistable vertex set by themselves.

The skeleton associated to a completed semistable vertex set is called a *completed skeleton*. It is defined similarly. The main difference is that the addition of type I points turns some open discs of  $X^{\text{an}} \setminus V$  into punctured discs. The skeleton of a punctured disc is an edge of infinite length.

**Convention.** We typically use the letter  $\Gamma$  in this chapter for a finite skeleton and  $\Sigma$  for a completed skeleton.

### *Skeleta associated to toric embeddings*

Let  $X$  be a smooth projective curve and let  $\varphi: X \rightarrow Y$  be a closed embedding of  $X$  into a toric variety  $Y$ . Let  $T$  be the dense torus in  $Y$ . Let  $X^\circ = \varphi^{-1}(T)$ .

**Definition 2.1.5.** The *completed extended skeleton associated to  $\varphi$*  is the set  $\Sigma(\varphi)$  of points in  $X^{\text{an}}$  that do not have an open neighborhood contained in  $(X^\circ)^{\text{an}}$  and isomorphic to an open disc. We write  $\mathring{\Sigma}(\varphi)$  for the skeleton  $\Sigma(\varphi)$  with its type I points removed.

**Example 2.1.6.** If  $Y$  is a product of  $\mathbf{P}^1$ 's, then  $\varphi$  is defined by a set of rational functions and  $X^\circ$  is the set of points that are neither zeroes nor poles of those functions. The skeleton  $\Sigma(\varphi)$  contains all of those zeroes and poles as type I points. ◇

### 2.1.6 Tropicalization of analytic curves

If  $Y$  is a projective space (or product of projective spaces) over  $K$ , then the map  $\text{Log}: Y \rightarrow \text{Trop}(Y)$  defined in subsection 2.1.1 extends to the analytification,  $Y^{\text{an}}$ . We call this map  $\text{trop}: Y^{\text{an}} \rightarrow \text{Trop}(Y)$ .

More generally, if  $Y$  is a toric variety, then there is a map  $\text{trop}: Y^{\text{an}} \rightarrow \text{Trop}(Y)$ . See [Pay09, Section 3] for the definition.

**Example 2.1.7.** When  $Y = \mathbf{P}^1 = \text{Proj } K[z_0, z_1]$ , the map  $\text{trop}: \mathbf{P}^1 \rightarrow \mathbf{TP}^1$  is given by

$$\text{trop}((p, |\cdot|_x)) = \log |z_1(p)|_x. \quad \diamond$$

When there is a closed embedding  $\varphi$  of  $X$  into the toric variety  $Y$  (e.g. if  $X$  is projective), we can use this to tropicalize  $X$  via

$$\text{trop}_\varphi := \text{trop} \circ \varphi^{\text{an}}: X^{\text{an}} \rightarrow \text{Trop}(Y).$$

The image of  $X^{\text{an}}$  under  $\text{trop}_\varphi$  is denoted  $\text{Trop}_\varphi(X)$ .

### 2.1.7 Fully faithful, totally faithful and smooth

Let  $\varphi: X \rightarrow Y$  be a map from  $X$  to a toric variety  $Y$ , that is generically finite and whose image meets the dense torus  $T$  of  $Y$ . Let  $U := \varphi^{-1}(T)$ . Let  $N$  be the cocharacter lattice of  $T$  and  $N_{\mathbf{R}} := N \otimes_{\mathbf{Z}} \mathbf{R}$ . The map  $\text{trop}_\varphi$  is called *totally faithful* (see [Che+16]) if it induces an isometry from the associated open skeleton  $\overset{\circ}{\Sigma}(\varphi)$  onto its image (which is exactly  $\text{trop}(X^{\text{an}}) \cap N_{\mathbf{R}}$ .) It is called *fully faithful* if it is further injective when restricted to  $\Sigma(\varphi)$ . This is equivalent to the statement that  $\text{trop}_\varphi$  is injective when restricted to  $\varphi^{-1}(Y \setminus T)$ .

The map  $\text{trop}_\varphi|_{\Sigma(\varphi)}$  is linear with integral slope on each edge of  $\Sigma(\varphi)$ . We call this slope the *stretching factor* of  $\text{trop}_\varphi$  on  $e$ . Identifying  $T$  with  $\mathbf{G}_m^n$ , the restriction  $\varphi|_U$  is given by rational functions  $f_1, \dots, f_n$  on  $X$ . Then the stretching factors of  $\text{trop}_\varphi$  on  $e$  is given by the gcd of the slopes of  $\log |f_i|_e, i = 1, \dots, n$  [BPR16, p. 5.6.1]. In particular,  $\varphi$  induces a fully faithful tropicalization if  $\text{trop}_\varphi|_{\Sigma(\varphi)}$  is injective and all stretching factors are equal to one.

Let  $\varphi: X \rightarrow Y$  be a closed embedding and let  $\Sigma(\varphi)$  be the associated completed extended skeleton. We say that  $\text{trop}_\varphi$  is a *smooth tropicalization* if it is fully faithful and further for every finite vertex  $x$  of  $\Sigma(\varphi)$  the primitive integral vectors along the edges adjacent  $\text{trop}_\varphi(x)$  span a saturated lattice in  $N$  of rank  $\deg(x) - 1$ .

Usually the conditions for smoothness for tropical curves do not reference fully faithfulness and instead weights. This is equivalent to our definition in view of [Jel20, Section 5].

### 2.1.8 Divisors and rational functions on a metric graph

If  $\Gamma$  is a  $\Lambda$ -metric graph then a ( $\Lambda$ -rational) *divisor* on  $\Gamma$  is a finite, formal integer-linear combination of  $\Lambda$ -rational points on  $\Gamma$ . These divisors form a free Abelian group, which we call  $\text{Div}_\Lambda(\Gamma)$ .

A *rational function* on  $\Gamma$  is a piecewise-linear function  $F$  with integer slopes and such that all the points where  $F$  is non-linear are  $\Lambda$ -rational. If these points where  $F$  is non-linear are called  $x_1, \dots, x_n$ , then the *principal divisor* associated to  $F$  is

$$\sum_{i=1}^n m_i x_i$$

where  $m_i$  is the sum of the outgoing slopes of  $F$  at  $x_i$ . The principal divisors on  $\Gamma$  form a subgroup, which we call  $\text{Prin}_\Lambda(\Gamma)$ .

If  $\tau: X^{\text{an}} \rightarrow \Gamma$  is the deformation retraction of  $X^{\text{an}}$  onto its skeleton, then  $\tau$  maps  $X(K)$  onto  $\Gamma(\Lambda)$ . We can therefore extend this map to a surjective map  $\tau_*: \text{Div}(X) \rightarrow \text{Div}_\Lambda(\Gamma)$ .

Let  $f \in K(X)^*$  be a rational function. Then  $\log |f|$  is a function on  $X^{\text{an}}$ . If  $F$  is the restriction of  $\log |f|$  to  $\Gamma$ , then it is known that  $F$  is a  $\Lambda$ -rational function. Moreover,

$$\tau_* \text{div}(f) = \text{div}(F).$$

This means that  $\tau_*$  takes principal divisors to principal divisors.

*Note.* These two facts about  $\log |f|$  are referred to as the “slope formula” or “non-Archimedean Poincaré-Lelong formula” in the literature. The formula was first stated and proved in our terminology by Baker, Payne and Rabinoff [BPR13], Theorem 5.15. The original result is due to Thuiller [Thu05] who phrased it in terms of potential theory. Thuiller’s formulation



closely resembles the classical formula for complex manifolds.

More results about the connection between  $\text{Div}(X)$  and  $\text{Div}_\Lambda(\Gamma)$  may be found in [Bak08b] and [BR15].

**Definition 2.1.8.** An effective divisor  $B$  on a metric graph  $\Gamma$  is called a *break divisor* if there exists a graph model  $G$  of  $\Gamma$  and edges  $e_1, \dots, e_g$  of  $G$  forming the complement of a spanning tree such that  $B = x_1 + \dots + x_g$  where  $x_i \in e_i$ .

Break divisors were first introduced by Mikhalkin and Zharkov [MZ08] and were used by An, Baker, Kuperberg, and Shokrieh [An+14] to give a geometric proof of Kirchhoff's Matrix-Tree Theorem.

### 2.1.9 Mumford curves

**Definition 2.1.9.** A smooth, projective curve  $X$  over  $K$  is called a *Mumford curve* if the genus of  $X$  is equal to the genus (i.e. the first Betti number) of its skeleton.

While the question of which curves admit fully or totally faithful tropicalizations is still open, it is known that only Mumford curves admit smooth tropicalizations.

**Theorem 2.1.10.** [Jel20, Theorem A] *Let  $X$  be a smooth projective curve. Then the following are equivalent*

1.  $X$  is a Mumford curve.
2. There exists an embedding  $\varphi: X \rightarrow Y$  for a toric variety  $Y$  such that  $\text{Trop}_\varphi(X)$  is smooth.

This theorem shows that, at least for the results of Section 2.6, we have to consider Mumford curves. The question of whether general smooth algebraic curves admit fully faithful tropicalizations is open for non-Mumford curves.

## 2.2 Construction of fully faithful tropicalization in 3-space

In this section,  $X$  will denote a Mumford curve over a complete, algebraically closed, non-Archimedean valued field  $K$  with analytification  $X^{\text{an}}$  and skeleton  $\Gamma$ . We take  $G$  to be a graph model of  $\Gamma$  with vertex set  $V = V(G)$  and edge set  $E = E(G)$ .

After possibly subdividing, we assume that  $G$  has edges  $e_1, \dots, e_g$  that form the complement of a spanning tree,  $T \subseteq E$ , and that no two edges  $e_i, e_j$  share a vertex.

We will define three piecewise-linear functions  $F_1, F_2, F_3$  on  $\Gamma$  whose graphs are depicted in Figures 2.2 to 2.5. To construct these piecewise-linear functions, we consider divisors on  $\Gamma$  and use the following lifting theorem.

**Theorem 2.2.1** (Jell). *Let  $D$  be a divisor on  $X$  of degree  $g$ . Given any break divisor  $B = x_1 + \dots + x_g$  on  $\Gamma$  supported on 2-valent points, if  $\tau_* D - B$  is principal then there exist liftings  $x'_1, \dots, x'_g \in X(K)$  such that  $\tau_* x'_i = x_i$  and such that  $D - \sum_{i=1}^g x'_i$  is a principal divisor.*

*Proof.* Theorem 3.2 of [Jel20]. □

Another equivalent way of writing this theorem is the following.

**Theorem 2.2.2.** *Let  $D = \sum_{i=1}^k a_i - \sum_{j=1}^k b_j$  be a principal divisor on  $\Gamma$ . Assume that  $\sum_{i=1}^g a_i$  is a break divisor supported on 2-valent points. Then, given preimages  $x_i$  and  $y_j$  for all  $i = g+1, \dots, k$  and all  $j = 1, \dots, k$  such that  $\tau(x_i) = a_i$  and  $\tau(y_j) = b_j$ , there exist  $x_1, \dots, x_g \in X(K)$  with  $\tau(x_i) = a_i$  such that  $\sum_{i=1}^k x_i - \sum_{j=1}^k y_j$  is a principal divisor on  $X$ .*

*Proof.* This follows from the lifting theorem applied with

$$D = \sum_{i=1}^k b_i - \sum_{i=g+1}^k a_i \text{ and } B = \sum_{i=1}^g x_i. \quad \square$$

### 2.2.1 Constructions of the piecewise-linear functions and lifting

We construct the piecewise-linear functions  $F_1$ ,  $F_2$  and  $F_3$  by specifying their divisors. To construct these divisors, we will need to choose, for each edge  $e$ , points which will be labeled  $c_e, a_e, p_e, q_e, b_e, d_e$  in the interior of  $e$ . This will be the order of the points in their respective edge. We also require that the pairs  $c_e, d_e$  and  $a_e, b_e$  and  $p_e, q_e$  are symmetric about the middle of their edges.

We will describe the exact position of these points inside their edges in section 2.3. The statements of this section do not depend on the choices made in section 2.3.

We pick the following additional data: For every edge  $e$ , we label one of its endpoints  $v(e)$  and the other one  $w(e)$  and we pick for each edge  $e$  a positive integer  $s(e)$ . We will describe which vertex is  $v(e)$  and which is  $w(e)$  in section 2.3 along with conditions for the integers  $s(e)$ .

Let  $\{e_1, \dots, e_g\}$  be the edges not in the spanning tree  $T$  and note that the following divisors are all principal

$$\begin{aligned}
 D_1 &= \sum_{e \in E} v(e) + w(e) - p_e - q_e, \\
 D_2 &= \sum_{e \in E} s(e) (v(e) + w(e) - p_e - q_e) + \sum_{i=1}^g -c_{e_i} + a_{e_i} + b_{e_i} - d_{e_i}, \\
 D_3 &= \sum_{e \in E} a_e - b_e.
 \end{aligned}$$

Let  $F_i$  be a piecewise-linear function such that  $\text{div}(F_i) = D_i$ . The graphs of  $F_i$  are depicted in Figures 2.2, 2.3, 2.4 and 2.5. Our graphs look similar to the graphs of the functions used by Baker and Rabinoff (and depicted in [BR15, Figure 1]), however they are tweaked to fit with our lifting theorem. Notice for example the slight bumps in Figure 2.5, which are there specifically to allow application of our lifting theorem.

We now want to lift these functions to  $X^{\text{an}}$  by lifting their divisors using Theorem 2.2.2.

**Proposition 2.2.3.** For every  $e$  there exist lifts  $a'_e, b'_e \in X(K)$  of  $a_e, b_e$  such that

$$D'_3 := \sum_{e \in E} a'_e - b'_e$$

is a principal divisor on  $X$ .

**Proposition 2.2.4.** For every point in  $\{v(e), w(e), p_e, q_e \mid e \in E\}$  there exist a lift in  $X(K)$ , which we denote by  $v(e)', w(e)', p'_e, q'_e$  respectively such that

$$D'_1 := \sum_{e \in E} v(e)' + w(e)' - p'_e - q'_e$$

is a principal divisor on  $X$ .

*Note.* In the previous two propositions, we did not prescribe any lifts for the points in the support of  $D_3$  or  $D_1$ . However, in the lifting theorem allows us to prescribe all but  $g$  lifts. In the following proposition we will do just that, using the full power of Theorem 2.2.2.

**Proposition 2.2.5.** Suppose that for every point in  $\{a_e, b_e, v(e), w(e), p_e, q_e \mid e \in E\}$ , we are given lifts  $a'_e, b'_e, v(e)', w(e)', p'_e, q'_e \in X(K)$  respectively. Then for every  $i = 1, \dots, g$ , there exist lifts  $c'_{e_i}$  and  $d'_{e_i}$  of  $c_{e_i}$  and  $d_{e_i}$  such that

$$D'_2 := \sum_{e \in E} s(e) (v(e)' + w(e)' - p'_e - q'_e) + \sum_{i=1}^g -c'_{e_i} + a'_{e_i} + b'_{e_i} - d'_{e_i}$$

is a principal divisor on  $X$ .

*Proof.* All three Propositions follow directly from Theorem 2.2.2. □

We let  $f_1, f_2, f_3 \in K(X)$  be such that  $\text{div}(f_i) = D'_i$  so that  $\log |f_i|_\Gamma = D_i$ . Let  $U$  be the open set of  $X$  obtained by removing all the points  $v'(e), w'(e), a'_e, b'_e, c'_e, d'_e, p'_e, q'_e$  for each edge  $e$ . Then we have the map

$$f := (f_1, f_2, f_3): U \rightarrow \mathbf{G}_m^3.$$

For every three-dimensional, proper toric variety  $Y$ , this map extends to a morphism

$$\varphi: X \rightarrow Y.$$

**Proposition 2.2.6.** *Assume that for a vertex  $v$  of  $\Sigma(\varphi)$ , the number of adjacent edges is coprime to  $\sum_{e:v \in e} s(e)$  and that  $\text{trop}_\varphi|_{\dot{\Sigma}(\varphi)}$  is injective. Then the tropicalization induced by  $\varphi$  is totally faithful.*

*Similarly, if  $\text{trop}_\varphi|_{\Sigma(\varphi)}$  is injective, then the tropicalization induced by  $\varphi$  is fully faithful.*

*Proof.* We have to check that for each domain of linearity of the functions  $\log |f_i|$ , the gcd of their slopes is equal to 1. The extended skeleton  $\Sigma$  associated to  $\varphi$  is given by taking  $\Gamma$  and at each point  $c_e, a_e, p_e, q_e, b_e, d_e$  adding a ray  $[c_e, c'_e)$  and so on. Note that here it is crucial that we were able to select the points we obtained in Proposition 2.2.3 and Proposition 2.2.4 and reuse them in Proposition 2.2.5, otherwise we would have to potentially add multiple edges.

On the finite edges we have  $\log |f_i| = F_i$ , so this can be checked directly (c.f. Figures 2.2, 2.3, 2.4 and 2.5. ).

On an infinite edge,  $e$ , the slope of  $\log |f_i|$  is the coefficient of  $D_i$  at the finite endpoint of  $e$ . So again this can be checked case by case. □

### 2.3 The right choice of parameters

We now describe conditions on the parameters for which, as we will show in the next section, the tropicalization map induced by  $(f_1, f_2, f_3)$  will be fully faithful.

By parameters, we mean: a subdivision of the skeleton  $\Gamma$  of  $X^{\text{an}}$  that is suitable, the distance of the points  $c_e, a_e, p_e, q_e, b_e$  and  $d_e$  from the vertices as well as the values  $r(v)$  for each vertex  $v$  and  $s(e)$  for each edge  $e$ .

### 2.3.1 Interval condition

Except for the symmetry of the pairs  $c_e, d_e, a_e, b_e$  and  $p_e, q_e$  about their edge's midpoint, we have complete freedom on where we choose these points on the interior of each edge. The arrangement of these points is pictured in Figure 2.6 which we will now describe.

Map each edge  $e$  to the real line so that it has one of its vertices,  $v(e)$ , at 0 and the other vertex,  $w(e)$  at  $\ell(e) =$  the length of  $e$ .

Then, we require that the points  $v(e), c_e, a_e, p_e$  can be grouped into disjoint intervals according to what kind of point they are. Namely, every point  $c_e$  should lie to the left of any point  $a_{e'}$ , should lie to the left of any point  $p_{e''}$ . The most restrictive requirement is that we want a point  $p_e$  to be to the left of the midpoint of any other edge.

We require that symmetric conditions hold if all the edges are right-aligned at their vertex  $w(e)$ . That is,  $q_e$  should be to the right of every midpoint and every point  $b_{e'}$  should be to the right of  $q_e$  and every point  $d_{e''}$  should be to the right of  $b_{e'}$ .

We will call this requirement on the arrangement of the points, the *interval condition*.

### 2.3.2 Conditions for $r(v)$

We now describe conditions for the constants  $r(v)$  that will be the values of  $F_3$  at the vertices  $v$  (i.e.  $r(v) = F_3(v)$ ). These constants are related to the points  $a_e$  and  $b_e$  by

$$d_e(a_e, b_e) = |r(w) - r(v)|$$

for an edge  $e = vw$ .

As such, we require that  $|r(w) - r(v)|$  is strictly smaller than the length of  $vw$ . By convention, we will write  $v(e)$  for the vertex of  $e$  with the smaller value of  $r$  and  $w(e)$  for the larger value.

We also require two additional properties for the values of  $r$ :

(R1)  $r(v)$  is distinct for each  $v \in V(G)$ .

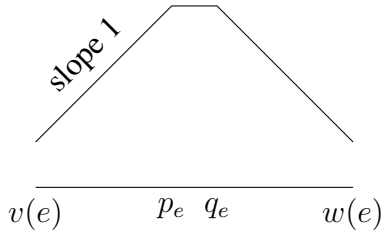

Figure 2.2: The graph of  $F_1|_e$ .

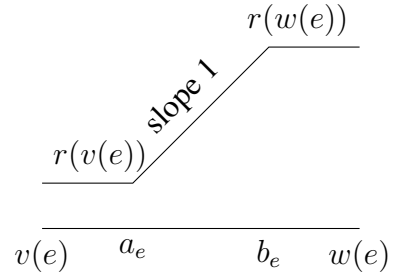

Figure 2.3: The graph of  $F_3|_e$ .

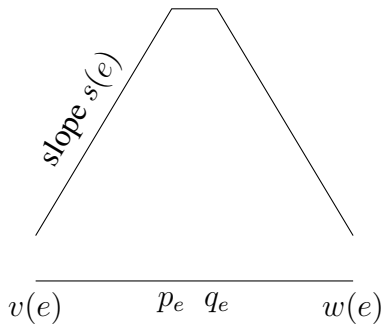

Figure 2.4: The graph of  $F_2|_e$  for  $e \in T$ .

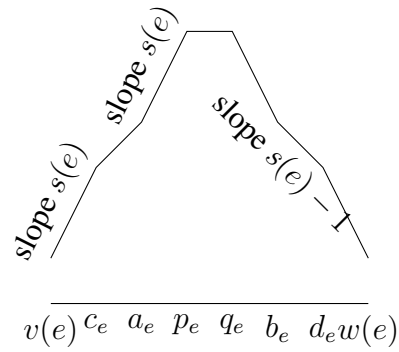

Figure 2.5: The graph of  $F_2|_e$  for  $e \notin T$ .

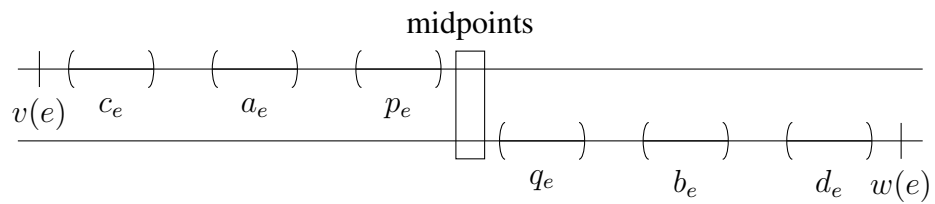

Figure 2.6: Where the points lie on the real line.

(R2) The distances  $d(a_e, v(e)) = d(b_e, w(e)) = F_1(a_e)$  are distinct for each  $e \in E(G)$ .

### 2.3.3 Further requirements on locations

In addition to having distinct values of  $F_1$  for  $a_e$ , we require the following conditions:

- for each edge  $e \notin T$ , the points  $c_e$  to be chosen such that the distances  $d_e(v(e), c_e) = F_1(c_e)$  are all distinct,
- and, for each edge  $e$ , we require the points  $p_e$  to be chosen such that the values of  $F_3(p_e) = r(v(e)) + d_e(p_e, a_e)$  are all distinct,
- and, for each edge  $e$ , we require that the points  $q_e$  are chosen such that the values of  $F_3(q_e) = r(w(e)) - d_e(q_e, b_e)$  are all distinct,
- and finally, we require that  $F_3(p_e) \neq F_3(q_{e'})$  for any  $e, e' \in E$ .

*Note.* These conditions do not impose a significant restriction because: the points are to be chosen from an interval, the  $\Lambda$ -rational points are dense, and there are only finitely many choices to avoid.

**Definition 2.3.1.** For each edge  $e$ , let  $\varphi_e: e \rightarrow [0, \ell(e)]$  denote the isometry with  $\varphi_e(v(e)) = 0$  and  $\varphi_e(w(e)) = \ell(e)$ . If  $x \in \Gamma$  is not a vertex then it is contained in a unique edge  $e$ , and we will write  $\varphi(x)$  for  $\varphi_e(x)$ .

### 2.3.4 Conditions for $s(e)$

Recall that to define  $F_2$  we have to choose for each edge,  $e$ , an integer  $s(e) > 1$ . We require that these integers satisfy the following conditions

(S1) For every edge  $e$ , the integers  $s(e)$  are all distinct.

(S2) For every edge  $e$ , the value of  $F_2$  on the interval  $[p_e, q_e]$ , is distinct.



(S3) For any  $e \in T$ ,  $e' \notin T$  and any  $x \in e$  we have  $F_2(x) < F_2(c_{e'})$ . Furthermore, the distance between  $F_2(p_e) = \max F_2|_e$  and  $F_2(c_{e'})$  exceeds (strictly)

$$\max_{y \in \Gamma} F_3(y) - \min_{y \in \Gamma} F_3(y) = \max_{v \in V(G)} r(v) - \min_{v \in V(G)} r(v).$$

(S4) For every edge  $e \notin T$ , the intervals  $[F_2(c_e), F_2(p_e)] \subseteq \mathbf{R}$  are disjoint. Again, the distance between these intervals should be large in the same sense as (S3). Namely, if  $F_2(p_e) < F_2(c_{e'})$  for a different edge  $e' \notin T$  then

$$F_2(c_{e'}) - F_2(p_e) > \max_{y \in \Gamma} F_3(y) - \min_{y \in \Gamma} F_3(y).$$

*Note.* Figure 2.7 on page 47 shows what (S3) and (S4) are designed to accomplish.

(S5) For all  $e \in T$  and  $e' \notin T$ . If  $x \in e'$  with  $\varphi(p_e) \leq \varphi(x) \leq \varphi(q_e)$  then  $F_2(x) > F_2(p_e) + s(e)\lambda$  for any  $\lambda \leq \max F_3 - \min F_3$ .

*Note.* The idea is that  $F_2(x) \approx F_2(p_{e'})$  and

$$F_2(p_{e'}) \approx s(e')F_1(p_{e'}) \gg s(e)F_1(p_e) = F_2(p_e).$$

This is to get around the fact that  $F_2|_{e'}$  is not simply equal to  $s(e')F_1|_{e'}$  as is the case in the construction of Baker and Rabinoff [BR15, Theorem 8.2].

(S6) For each  $v \in V$ ,  $\deg(v)$  is coprime to  $\sum_{e \ni v} s(e)$ .

## 2.4 Injectivity

In this section we continue with the notation from the previous section. Let  $X$  be a Mumford curve with a finite skeleton  $\Gamma$  and a graph model  $(V, E)$ , Assume that for each  $e \in E$ , we have chosen points  $c_e, a_e, p_e, q_e, b_e, d_e$  satisfying the interval condition. Let  $Y$  be a proper

toric variety of dimension 3, and  $\varphi: X \rightarrow Y$  the morphism that is, on the dense torus, given by the functions  $f_1, f_2, f_3$  constructed in Section 2.2.

Again,  $F_1, F_2, F_3$  are piecewise linear functions with  $F_i = \log |f_i|$ . For convenience, we will choose  $F_1$  and  $F_2$  to take the value 0 at any vertex in  $V$ .

**Proposition 2.4.1.** *Let points be chosen on each edge satisfying the interval condition. Choose parameters  $r(v)$  and  $s(e)$  satisfying (R1) and (R2) and (S1)–(S6). Then the map  $\text{trop}_\varphi|_{\dot{\Sigma}}: \dot{\Sigma} \rightarrow \mathbf{R}^3$  is injective.*

The proof of this proposition is broken up into several lemmas. In each, we assume the conditions of Proposition 2.4.1 hold.

**Lemma 2.4.2.** *Suppose that  $x, y \in \Gamma \setminus V$  such that  $F_1(x) = F_1(y)$  and  $F_2(x) = F_2(y)$ . Then  $x$  and  $y$  are contained in the same edge  $e$  of  $\Gamma$  and one of the following holds*

1.  $x = y$ ,
2.  $x$  is the reflection of  $y$  about the middle of  $e$ ,
3.  $x, y \in [p_e, q_e]$ .

*Proof.* By reflecting  $x$  or  $y$  about the middle of their respective edges  $e_1$  and  $e_2$  if necessary, we may assume that  $v(e_1)$  and  $v(e_2)$  are the respective closest vertices. Further, if  $x$  is contained in  $[p_{e_1}, q_{e_1}]$ , we may replace it by  $p_{e_1}$  and the same goes for  $y$  and  $p_{e_2}$ .

Now we have to show that after these replacements, we have  $x = y$ . First observe that (S4) and (S5) imply that if at least one of  $e_1, e_2$  is not in  $T$ , then  $F_2(x) = F_2(y)$  imply that either  $e_1 = e_2$  (in which case  $F_1(x) = F_1(y)$  implies  $x = y$ ) or both  $\varphi(x) < \varphi(c_{e_1})$  and  $\varphi(y) < \varphi(c_{e_2})$ —which is the interval on which  $F_2|_e = s(e)F_1|_e$  regardless of whether  $e \in T$  or not.

And now we have

$$d_{e_1}(v(e_1), x) = F_1(x) = F_1(y) = d_{e_2}(v(e_2), x)$$

and

$$s(e_1) d_{e_1}(v(e_1), x) = F_2(x) = F_2(y) = s(e_2) d_{e_2}(v(e_2), x).$$

It follows from these equations that  $s(e_1) = s(e_2)$  and thus  $e_1 = e_2$ . Then the first equation implies  $x = y$ .  $\square$

**Lemma 2.4.3.** *The map  $F|_{\Gamma}: \Gamma \rightarrow \mathbf{R}^3$  is injective.*

*Proof.* Suppose  $x, y \in \Gamma$  and  $F(x) = F(y)$ . If  $F_1(x) = F_1(y) = 0$  then  $x$  and  $y$  are vertices and so  $r(x) = F_3(x) = F_3(y) = r(y)$ . Since  $r$  takes distinct values on distinct vertices, this means  $x = y$ .

Otherwise, if  $F_1(x) = F_1(y) \neq 0$  then  $x$  and  $y$  are not vertices. It now follows from Lemma 2.4.2 that  $x$  and  $y$  lie on the same edge. If  $x, y \in [p_e, q_e]$  then  $x = y$  since  $F_3|_{[p_e, q_e]}$  is injective. Otherwise, Lemma 2.4.2 gives us that  $x = x'$  or  $x$  is  $y$  reflected about the midpoint of its edge. On the other hand,  $F_3$  is antisymmetric on each edge so  $F_3(x) = F_3(y)$  means that  $x = y$ .  $\square$

### 2.4.1 Infinite rays

Table 2.1: Directions of infinite rays and their limit in  $\mathbf{TP}^3$  and  $(\mathbf{TP}^1)^3$ .

Starting Point	Direction	Limit in $\mathbf{TP}^3$	Limit in $(\mathbf{TP}^1)^3$
$c_e; (e \notin T)$	$(0, 1, 0)$	$[-\infty : F_2(c_e) : -\infty : -\infty]$	$(F_1, \infty, F_3)$
$a_e; e \notin T$	$(0, -1, -1)$	$[F_1(a_e) : -\infty : -\infty : 0]$	$(F_1(a_e), -\infty, -\infty)$
$a_e; e \in T$	$(0, 0, -1)$	$[F_1(a_e) : F_2(a_e) : -\infty : 0]$	$(F_1(a_e), F_2(a_e), -\infty)$
$p_e$	$(1, s(e), 0)$	$[-\infty : F_2(p_e) : -\infty : -\infty]$	$(\infty, \infty, F_3(p_e))$
$q_e$	$(1, s(e), 0)$	$[-\infty : F_2(q_e) : -\infty : -\infty]$	$(\infty, \infty, F_3(q_e))$
$b_e; e \in T$	$(0, 0, 1)$	$[-\infty : -\infty : F_3(b_e) : -\infty]$	$(F_1(b_e), F_2(b_e), \infty)$
$b_e; e \notin T$	$(0, -1, 1)$	$[-\infty : -\infty : F_3(b_e) : -\infty]$	$(F_1(b_e), -\infty, \infty)$
$d_e; (e \notin T)$	$(0, 1, 0)$	$[-\infty : F_2(d_e) : -\infty : -\infty]$	$(F_1(d_e), \infty, F_3(d_e))$
$v \in V(G)$	*	$[-\infty : -\infty : F_3(v) : 0]$	$(-\infty, -\infty, F_3(v))$

$$* = \left( -\deg(v), -\sum_{e \ni v} s(e), 0 \right)$$

For each of the points  $a_e, b_e, c_e, d_e, p_e, q_e$  as well as each vertex of  $G$ , we have an infinite ray in  $\Sigma$ . For example the ray from  $a_e$  to  $a'_e$ . Let us refer to each of these rays as  $p$ -rays,  $c$ -rays,  $a$ -rays, etc.

In this section, we prove that image of the  $a, b, c, d, p$ , and  $q$  rays do not intersect each other in  $\mathbf{R}^3$ , or the image of the finite skeleton,  $\Gamma$ . The intersections of these rays at the boundary strata of  $\mathbf{TP}^3$  and  $(\mathbf{TP}^1)^3$  is recorded in Table 2.1.

The direction of each of these rays in the image  $F(\Sigma)$  is given by looking at the sum of the incoming slopes at the point in  $F$ . For reference, these directions are also recorded in Table 2.1.

**Lemma 2.4.4.** *The image of  $[c_e, c'_e)$  or  $[d_e, d'_e)$  under  $F$  intersects the image of  $\Gamma$  only at  $c_e$  or  $d_e$  respectively.*

*Proof.* The first two coordinates of the ray at  $c_e$  and the ray at  $d_e$  are identical, so we will only make a distinction between  $c$ -ray or  $d$ -ray when we start talking about the third coordinate.

A point on  $F([c_e, c'_e))$  or  $F([d_e, d'_e))$  is of the form

$$F(c_e \text{ or } d_e) + \lambda(0, 1, 0)$$

for some  $\lambda \geq 0$ . Suppose that some point of this ray coincides with  $F(x)$  for some  $x \in \Gamma$ , belonging to an edge  $e'$ , which would mean  $F(x) = F(c_e \text{ or } d_e) + (0, \lambda, 0)$ .

First, if  $e' \in T$ , then by (S3),  $F_2(x) < F_2(c_e) \leq F_2(c_e) + \lambda$ . Therefore, we must have  $e' \notin T$ .

Let  $v$  denote the vertex closest to  $x$ . Then we have

$$d_{e'}(v, x) = F_1(x) = F_1(c_e) = d_e(v(e), c_e).$$

By the interval condition, this implies that  $x \in [v, a_{e'}]$  or  $x \in [b_{e'}, w]$ .

Now, looking at the third coordinates, we have

$$r(v) = F_3(x) = F_3(c_e \text{ or } d_e) = r(v(e) \text{ or } w(e)).$$

By (R1) we must have  $v = v(e)$  or  $v = w(e)$ . Since the edges outside  $T$  do not share a vertex, this means  $e = e'$ .

Since  $e = e'$  and  $F_1(x) = F_1(c_e)$ , we either have  $x = c_e$  or  $x = d_e$ . If we started with a  $c$ -ray, then  $F_3(x) = F_3(c_e)$  implies  $x = c_e$  because  $F_3$  is antisymmetric on  $[c_e, d_e]$  and likewise if we started with a  $d$ -ray.  $\square$

**Lemma 2.4.5.** *For  $e \notin T$ , the image of  $[a_e, a'_e)$  and of  $[b_e, b'_e)$  intersects the image of  $\Gamma$  only at  $a_e$  or  $b_e$  respectively.*

*Proof.* As before, the first two coordinates of the  $a_e$  and  $b_e$ -rays are identical, so we will only make a distinction between  $a$ -ray or  $b$ -ray for the third coordinate.

Suppose that  $x \in \Gamma$  and  $F(x) = F(a_e \text{ or } b_e) + \lambda(0, -1, \pm 1)$ . Let  $e'$  be an edge containing  $x$ . Since  $F_1(x) = F_1(a_e)$ , we have  $x \in [c_{e'}, p_{e'}]$  or  $x \in [q_{e'}, d_{e'}]$  by the interval condition. Therefore,  $F_2(x) \in [F_2(c_{e'}), F_2(p_{e'})]$ .

On the other hand, by (S3) or (S4) the distance between  $F_2(x)$  and  $F_2(a_e)$  is quite large if  $e' \neq e$ . Specifically, if  $e' \neq e$  we have

$$\lambda = F_2(a_e) - F_2(x) > \max F_3 - \min F_3 \geq |F_3(a_e \text{ or } b_e) - F_3(x)| = \lambda.$$

See Figure 2.7 for a picture of the situation.

Since this is impossible, we must have  $e' = e$ . Now, from  $F_1(x) = F_1(a_e)$  we have either  $x = a_e$  or  $x = b_e$ , and then we can use  $F_3$  to distinguish between  $a_e$  and  $b_e$ .  $\square$

**Lemma 2.4.6.** *For  $e \in T$ , the image of  $[a_e, a'_e)$  or  $[b_e, b'_e)$  intersects the image of  $\Gamma$  only at  $a_e$  or  $b_e$  respectively.*

*Proof.* Suppose that  $x \in \Gamma$  and  $F(x) = F(a_e \text{ or } b_e) + (0, 0, \pm\lambda)$  for some  $\lambda \in \mathbf{R}_{\geq 0}$ . Then

in particular,  $F_1(x) = F_1(a_e)$  and  $F_2(x) = F_2(a_e)$  so by Lemma 2.4.2 we have  $x = a_e$  or  $x = b_e$ .

For the  $[a_e, a'_e)$ -ray, we have  $F_3(b_e) > F_3(a_e) \geq F_3(a_e) - \lambda = F_3(x)$ . So we can't have  $x = b_e$ , hence we must have  $x = a_e$ .

Likewise, for the  $[b_e, b'_e)$ -ray, we have  $F_3(a_e) < F_3(b_e) \leq F_3(b_e) + \lambda = F_3(x)$ .  $\square$

**Lemma 2.4.7.** *The image of  $[p_e, p'_e)$  or  $[q_e, q'_e)$  intersects the image of  $\Gamma$  only at  $p_e$  or  $q_e$ , respectively.*

*Proof.* Let  $x \in \Gamma$  with  $F(x) = F(p_e \text{ or } q_e) + \lambda(1, s(e), 0)$  and  $\lambda \geq 0$ . Let  $e'$  be an edge that contains  $x$  and  $e \neq e'$ .

Suppose, for now, that  $x$  is closest to  $v(e')$  since this part of the argument is symmetrical.

First, suppose  $e, e' \in T$ . Then  $F_1(x) = F_1(p_e) + \lambda$  means  $F_2(x) = s(e')F_1(x) = s(e')F_1(p_e) + s(e')\lambda$ . But, on the other hand,  $F_2(x) = F_2(p_e) + s(e)\lambda = s(e)F_1(p_e) + s(e)\lambda$ . This is impossible unless  $e = e'$ .

Next, because  $\min\{\varphi(x), \varphi(p_{e'})\} = F_1(x) \geq F_1(p_e) = \varphi(p_e)$ , we have  $\varphi(p_e) \leq \varphi(x) \leq \varphi(q_e)$  by the interval condition. Thus,

$$\lambda = F_1(x) - F_1(p_e) \leq d(p_e, q_e) \leq d(a_e, b_e) \leq \max F_3 - \min F_3.$$

We should think of  $\lambda$  as being small.

If  $e \notin T$  then already  $F_2(p_e) + s(e)\lambda \geq F_2(p_e) > F_2(x)$  for any  $x \in e \notin T$ .

If  $e \in T$  but  $e' \notin T$  then we appeal to (S5) to see that this is impossible.

Thus,  $e = e'$  and from now the argument is no longer symmetric. Next, since  $F_1(p_e) = \max_{y \in e} F_1(y)$ , it must be that  $\lambda = 0$  and  $x \in [p_e, q_e]$ . Since  $F_3$  is injective on this interval, we have  $x = p_e$  or  $x = q_e$  depending on whether we started with a  $p$ -ray or a  $q$ -ray.  $\square$

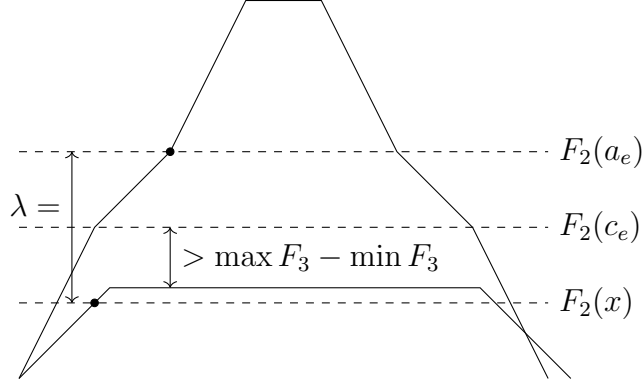

Figure 2.7: Situation in Lemma 2.4.5

### Comparing between rays

*Note.* These proofs are all quite short and just come down to requiring some parameters being distinct.

**Lemma 2.4.8.** *Any pair of distinct  $c$ -rays or pair of distinct  $d$ -rays do not intersect.*

*Proof.* An intersection between two  $c$ -rays has the form  $F(c_e) + (0, \lambda, 0) = F(c_{e'}) + (0, \mu, 0)$  for some  $\lambda$  and  $\mu$ . Because we chose distinct values for  $F_1(c_e) = d_e(c_e, v(e))$ , and  $F_1(c_e) = F_1(c_{e'})$ , therefore  $e = e'$ .

For  $d$ -rays, simply change  $c$  to  $d$  and  $v(e)$  to  $w(e)$ . □

**Lemma 2.4.9.** *Any pair of distinct  $p$ -rays or pair of distinct  $q$ -rays do not intersect.*

*Proof.* Two  $p$ -rays look like  $F(p_e) + (\lambda, s(e)\lambda, 0) = F(p_{e'}) + (\mu, s(e)\mu, 0)$ . Because we chose distinct values of  $F_3(p_e) = r(v(e)) + d_e(p_e, a_e)$ , and  $F_3(p_e) = F_3(p_{e'})$ , therefore  $e = e'$ .

Likewise, we chose distinct values for  $F_3(q_e)$  so no pair of distinct  $q$ -rays can intersect. □

**Lemma 2.4.10.** *Any pair of distinct  $a$ -rays or  $b$ -rays do not intersect.*

*Proof.* The first coordinate of every point in an  $a$ -ray or  $b$ -ray is  $F_1(a_e)$ . By (R2), these quantities are distinct. □

**Lemma 2.4.11.** *No pair of  $a, b, c, d, p,$  or  $q$ -rays intersect, except possibly  $a$  with  $b,$   $c$  with  $d$  and  $p$  with  $q.$*

*Proof.* Note that the first coordinates of these rays are  $F_1(a_e), F_1(c_e)$  and  $F_1(p_e) + \lambda$  respectively. By the interval condition, these are ordered

$$F_1(a_e) < F_1(c_e) < F_1(p_e) \leq F_1(p_e) + \lambda. \quad \square$$

**Lemma 2.4.12.** *An  $a$ -ray cannot intersect a  $b$ -ray.*

*Proof.* Because the values of  $F_1(a_e) = F_1(b_e)$  are distinct, an  $a$ -ray can only possibly intersect the  $b$ -ray belonging to the same edge. But then

$$F_3(a_e) - \lambda \leq F_3(a_e) < F_3(b_e) \leq F_3(b_e) + \mu$$

for all  $\lambda, \mu \geq 0.$  □

**Lemma 2.4.13.** *A  $c$ -ray cannot intersect a  $d$ -ray.*

*Proof.* Because the values of  $F_1(c_e) = F_1(d_e)$  are distinct, a  $c$ -ray can only possibly intersect the  $d$ -ray belonging to the same edge. But then  $F_3(c_e) < F_3(d_e).$  □

**Lemma 2.4.14.** *A  $p$ -ray cannot intersect a  $q$ -ray.*

*Proof.* Because the values of  $F_1(p_e) = F_1(q_e)$  are distinct, a  $p$ -ray can only possibly intersect the  $q$ -ray belonging to the same edge. But then  $F_3(p_e) < F_3(q_e).$  □

**Lemma 2.4.15.** *Two distinct vertex rays do not intersect.*

*Proof.* Note that the third coordinate of a vertex ray is  $F_3(v) = r(v)$  and these values are distinct by (R1). □

**Lemma 2.4.16.** *A vertex ray does not intersect an  $c, d, a, b, p,$  or  $q$ -ray.*



*Proof.* Note that the first coordinate of a vertex ray is

$$F_1(v) - \lambda \deg(v) = -\lambda \deg(v) \leq 0 < F_1(c_e) < F_1(a_e) < F_1(p_e). \quad \square$$

## 2.5 Fully and totally faithfulness

In this section we prove Theorem 2.A from the introduction. The majority of the work was done in the previous section. In this section we show that all the assumptions we made there can actually be achieved. We fix a Mumford curve  $X$ .

**Theorem 2.5.1.** *Let  $Y$  be a proper toric variety of dimension three. Then there exists a morphism  $\varphi: X \rightarrow Y$  such that the induced tropicalization is totally faithful.*

*Proof.* Let  $\Gamma$  be a finite skeleton of  $X$ . By simply adding a leaf edge to  $\Gamma$ , we may assume that  $\Gamma$  has a leaf edge. We pick a graph model  $G = (V, E)$  for the  $\Lambda$ -metric graph  $\Gamma$ , and we chose the points  $c_e, a_e, p_e, q_e, b_e, d_e$  satisfying the interval condition, and we pick values  $r(v)$  such that (R1) and (R2) are satisfied. Now since we assumed that  $\Gamma$  has a leaf edge, Lemma 2.5.2 shows that we can pick  $s(e)$  for  $e \in E$  such that (S1)–(S6) are satisfied.

The rational functions  $f_1, f_2, f_3$  constructed in Propositions 2.2.3, 2.2.4 and 2.2.5 define a rational map  $X \rightarrow \mathbf{G}_m^3$ . Identifying the dense torus of  $Y$  with  $\mathbf{G}_m^3$  and using the fact that both  $X$  and  $Y$  are proper, we obtain a morphism  $\varphi: X \rightarrow Y$ .

By Proposition 2.4.1, the map  $\text{trop}_\varphi|_{\dot{\Sigma}(\varphi)}$  is injective. By Proposition 2.2.6, this means that  $\text{trop}_\varphi$  is totally faithful.  $\square$

**Lemma 2.5.2.** *If  $\Gamma$  has a leaf edge, it is possible to pick  $s(e)$  in a way such that they satisfy (S1)–(S6).*

*Proof.* Let us focus on (S6) first. Pick any set of numbers  $s(e)$  for all  $e \in E$ . We pick a point  $z$  that lies in the interior of an edge and subdivide  $\Gamma$  by introducing  $z$  as a vertex. Let  $v$  and  $w$  be two vertices of  $\Gamma$ , joint by an edge  $e$ . Note that one can always achieve that (S6) holds at  $v$  by changing  $s(e)$  an appropriate amount.

Note further that for any vertex  $v$  except  $z$ , there exists a vertex  $w$  that lies closer to  $z$  than  $v$ . For every  $v$  fix such a choice  $w_v$ . Now working one way closer to  $z$ , by each time changing  $s(e_v)$ , where  $e_v$  is the edge joining  $v$  and  $w_v$ , we get  $S(6)$  to hold for all vertices except  $z$ . We now add a leaf edge  $e$  at  $z$  and are done, since we can pick  $s(e)$  in a way such that (S6) holds at  $z$ .

The other properties can all be achieved by making the  $s(e)$  very large with large differences between them. This can be achieved by adding multiples of  $\prod_{v \in \Gamma} \deg(v)$  to the  $s(e)$ , so they remain coprime.  $\square$

Now let us take a closer look at two particular toric varieties:  $\mathbf{P}^3$  and  $(\mathbf{P}^1)^3$ . The functions  $f_1, f_2, f_3$  are the ones constructed in Propositions 2.2.3, 2.2.4 and 2.2.5 with the parameters chosen as in Section 2.3.

**Proposition 2.5.3.** *Let  $\varphi: X \rightarrow \mathbf{P}^3; x \mapsto [f_1(x) : f_2(x) : f_3(x) : 1]$ . Then the induced tropicalization is not fully faithful.*

**Theorem 2.5.4.** *Let  $\varphi: X \rightarrow (\mathbf{P}^1)^3; x \mapsto (f_1(x), f_2(x), f_3(x))$ . Then the induced tropicalization is fully faithful.*

*Proof.* Both these statements follow from Table 2.1 that lists the endpoints of the rays in the respective compactifications together with the requirements of subsection 2.3.3 that force the endpoints to be distinct.  $\square$

## 2.6 Resolution of singularities

### 2.6.1 A conceptual approach

Throughout this section, we fix a Mumford curve  $X$  and a morphism  $\varphi: X \rightarrow Y$  for a toric variety  $Y$  that induces a fully faithful tropicalization.

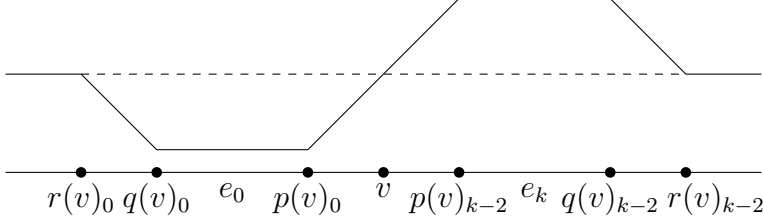

Figure 2.8: The graph of  $F_{e_k}(v)$  along the edges  $e_k(v)$  and  $e_0(v)$ . The function  $F_{e_k}$  is constant 0 on all other edges.

**Definition 2.6.1.** Let  $\text{Trop}_\varphi(X)$  be the corresponding tropical curve in  $\mathbf{R}^n$  and let  $x \in \text{Trop}_\varphi(X)$ . We define the *local degree of non-smoothness* of  $\text{Trop}_\varphi(X)$  at  $x$  to be

$$n_\varphi(x) = \deg(x) - 1 - \max\{k \mid \text{tangent vectors } v_1, \dots, v_k \text{ span a saturated lattice of rank } k\}. \quad (2.1)$$

*Note.* Consider the tropical curve in Figure 2.9. The circled point  $x$  has degree 4, one can find two tangent vectors that span  $\mathbf{Z}^2$ , but any three will still span  $\mathbf{Z}^2$ . We conclude that  $n_\varphi(x) = 1$ .

In general,  $x$  is a smooth point if and only if  $n_\varphi(x) = 0$ .

**Theorem 2.6.2.** *With notation as above, there exists a rational function  $f$  on  $X$  such that if we denote by  $\varphi': X \rightarrow Y \times \mathbf{P}^1, x \mapsto (\varphi(x), f(x))$  the associated embedding,  $\varphi'$  is fully faithful and*

$$n_{\varphi'}(z) = \begin{cases} n_\varphi(z) - 1 & \text{if } n_\varphi(z) > 0 \\ 0 & \text{if } n_\varphi(z) = 0 \end{cases}$$

for all  $z \in \Sigma(\varphi)$ .

*Proof.* For each vertex  $z$  in  $\Sigma_\varphi$  such that  $n_\varphi(z) > 0$ , pick tangent vectors  $e(z)_2, \dots, e(z)_{k+1}$  which span a saturated lattice as in(2.1). Further, fix two other adjacent edges  $e(z)_0$  and  $e(z)_1$ . In both  $e(z)_0$  and  $e(z)_1$  we choose points  $p(z)_i, q(z)_i, r(z)_i \in e(z)_i$  that are close to

$z$ , in the sense that they are closer to  $z$  than to the other vertex of  $e(z)_i$ . Further they should satisfy  $d(p(z)_i, z) = d(q(z)_i, r(z)_i)$ .

We now let

$$D_z = -p(z)_1 - q(z)_1 + r(z)_1 + p(z)_0 + q(z)_0 - r(z)_0 \text{ and}$$

$$D = \sum_{z \in \Sigma, n(z) > 1} D_z.$$

Let  $\Gamma$  be the finite skeleton obtained from  $\Sigma(\varphi)$  that is obtained by removing the infinite edges. Let  $\Gamma'$  be a subdivision of  $\Gamma$  such that all the  $r(v), q(v), p(v)$  are vertices. Now we pick edges  $e_1, \dots, e_g$  of  $\Gamma$  that form the complement of a spanning tree and in each edge we pick points  $s_1^j, s_2^j, s_3^j, s_4^j$  that occur on  $e_j$  in this order and satisfy  $d_{e_j}(s_1^j, s_2^j) = d_{e_j}(s_3^j, s_4^j)$ . Denote by  $P$  the divisor

$$P = \sum_{j=1}^g s_1^j - s_2^j - s_3^j + s_4^j$$

on  $\Gamma$ . Now by the lifting theorem (Theorem 2.2.2), we find lifts of all points in the support of  $D + P$  such that the divisors  $D'$  and  $P'$  satisfy that  $D' + P'$  is principal and  $\tau_* P' = P$  and  $\tau_* D' = D$ .

Let  $f$  be such that  $\text{div}(f) = D' + P'$ . We claim that  $f$  has the required properties. One checks easily that the tropicalization is again fully faithful.

Let  $z$  be a vertex of  $\Sigma(\varphi)$  and  $v_1, \dots, v_{k+1}$  be as above. Then the images of the tangent vectors at  $z$  are now

$$(v_1, 1) (v_2, 0) \dots (v_{k+1}, 0). \tag{2.2}$$

The lattice  $L'$  spanned by the vectors in (2.2) is of rank  $k + 1$ . We have  $\mathbf{Z}^{n+1}/L' \cong \mathbf{Z}^n/L$ , using the map

$$\mathbf{Z}^{n+1} \rightarrow \mathbf{Z}^n; (x_1, \dots, x_n) \mapsto (x_1 - v^1 x_{n+1}, \dots, x_n - v^n x_{n+1}),$$

where  $v_1 = (v^1, \dots, v^n)$ . In particular,  $L'$  is saturated. Since we do not add any edges at  $z$ , we have  $n_{\varphi'}(z) = n_{\varphi}(z) - 1$ .

If  $z$  is a vertex with  $n_{\varphi}(z) = 1$ , then  $\log |f|$  is constant in a neighborhood of  $z$  and thus  $n_{\varphi'}(z) = 1$ .

If  $z$  is one of the points in the support of  $D$ , then it is contained in an edge of  $\Sigma$ . Denote by  $w$  the vector in the direction of  $e$  in  $\text{Trop}_{\varphi}(X)$ . Then  $z$  is of degree 3 in  $\Sigma'$  and the set of direction vectors is either

$$\{(w, 1); (w, 0); (0, -1)\} \text{ or } \{(w, -1); (w, 0); (0, 1)\}.$$

In particular, those span a saturated lattice of rank 2 and  $n_{\varphi'}(z) = 1$ . □

**Corollary 2.6.3.** *Let  $n(\varphi) = \max_{z \in \Sigma} (n_{\varphi}(z))$ . Then there exist  $n(\varphi)$  rational functions  $f_1, \dots, f_{n(\varphi)}$  on  $X$  such that if we denote by*

$$\begin{aligned} \varphi' : X &\rightarrow Y \times (\mathbf{P}^1)^{n(\varphi)}, \\ x &\mapsto (\varphi(x), f_1(x), \dots, f_{n(\varphi)}(x)) \end{aligned}$$

*the associated embedding,  $\text{Trop}'_{\varphi}(X)$  is smooth.*

*Proof.* This follows by applying Theorem 2.6.2 inductively until  $n_{\varphi'}(z) = 0$  for all  $z$ . □

## 2.6.2 Application to our situation

In this section, we prove the following theorem:

**Theorem 2.6.4.** *Let  $X$  be a Mumford curve. Let  $C$  be the maximal degree of a vertex on the minimal skeleton  $\Gamma$  of  $X$ . Then there exists a map  $X \rightarrow (\mathbf{P}^1)^{C+2}$  that induces a smooth tropicalization of  $X$ .*

*Note.* This is 3 more than the optimal bound of  $C - 1$  that is determined by the definition of smoothness in terms of spans of direction vectors (c.f. subsection 2.1.7).

*Proof.* Let  $X \rightarrow (\mathbf{P}^1)^3$  be a map that induces by fully faithful tropicalization, as in Theorem 2.5.4. Note that the maximum degree of a vertex in  $\Sigma(\varphi)$  is  $C + 1$ , as we add one infinite edge at every vertex. Let  $z$  be a vertex of  $\Gamma$  and  $e_1, \dots, e_k$  the adjacent edges. Let  $e_0$  be the adjacent infinite edge in  $\Sigma$ . The tangent vectors in the tropicalization we constructed are of the form

$$(1, s_{e_1}, 0), \dots, (1, s_{e_k}, 0), (k, -\sum s_{e_i}, 0).$$

Unfortunately, no two of these span a saturated lattice of rank 2. We conclude that  $n_\varphi(z) = \deg_\Sigma(x) - 2 = \deg_\Gamma(z) - 1$ .

Since all other  $z \in \Sigma(\varphi)$  are at most trivalent, we conclude that  $n(\varphi) = C - 1$ .

The result now follows from Corollary 2.6.3 and the fact that  $C - 1 + 3 = C + 2$ .  $\square$

**Corollary 2.6.5.** *Let  $X$  be a Mumford curve of genus  $g$ . Then there exists a map  $X \rightarrow (\mathbf{P}^1)^{2g+2}$  that induces a smooth tropicalization of  $X$ .*

*Proof.* The minimal skeleton of a genus  $g$  Mumford curve has first Betti number  $g$ . Any vertex in a graph with genus  $g$  has degree at most  $2g$ . Thus the Corollary follows from Theorem 2.6.4.  $\square$

## 2.7 A genus 2 curve

A construction for tropicalizing certain genus 2 Mumford curves has been given by Wagner [Wag17]. For skeleta consisting of two loops joined at a common point, his construction is pictured in Figure 2.9. In ambient dimension 2, there is an intersection point. Wagner fixes this by adding in a third rational function to resolve the crossing in ambient dimension 3.

Wagner’s construction does not consider the singularity at the four-valent vertex and further analysis is required to show this point can be made smooth.

In this section, we show how to approach such tropicalization questions combinatorially from a rough-draft picture and how resolving this four-valent point comes “for free” with our approach.

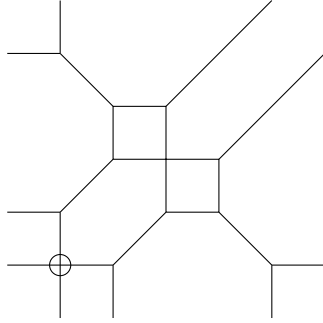

Figure 2.9: First step of Wagner's construction of a tropicalization of a genus two curve with an intersection circled.

### 2.7.1 Picturing the construction

Picturing how the skeleton should be embedded in  $\mathbf{TP}^3$  tells us how to construct the divisors. The first picture we visualize is just two hexagons attached at a common vertex and contained in the planes  $z = 0$  and  $x = y$  respectively. Second, we figure out how all the infinite rays should go so that the rays have directions  $(-1, 0, 0)$  or  $(0, -1, 0)$  or  $(0, 0, -1)$  or  $(1, 1, 1)$  so that we can guarantee that they do not intersect in the boundary strata of  $\mathbf{TP}^3$ . This gives us the picture of Figure 2.10.

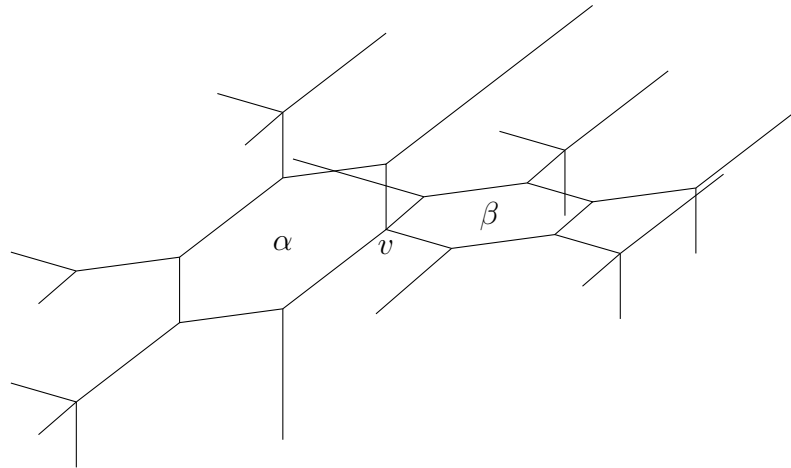

Figure 2.10: First draft of how the genus 2 skeleton is embedded in  $\mathbf{TP}^3$ .

Let  $X^{\text{an}}$  be the analytification of a curve whose skeleton consists of two loops,  $\alpha$  and  $\beta$ , connected at a common point,  $\omega$ .

In order to form the hexagons, we need to choose 5 points spaced equidistant around

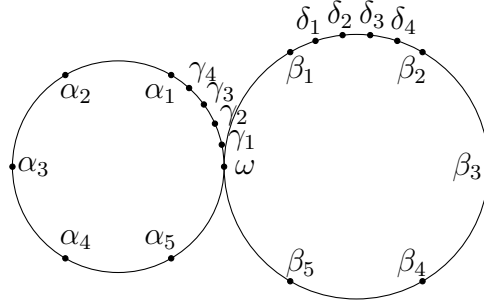

Figure 2.11: Skeleton  $\Gamma$  of  $X$ .

each loop of the skeleton. To that end, let  $\alpha_1, \dots, \alpha_5$  be points spaced equidistant around  $\alpha$  and  $\beta_1, \dots, \beta_5$  equidistant around  $\beta$ . See Figure 2.11.

We will arrange so that  $\alpha$  is the hexagon in the  $x = y$  plane and  $\beta$  is in the  $z = 0$  plane.

For the first divisor, we note that the  $x$ -coordinate stays constant between  $\omega$  and  $\alpha_1$ , then decreases linearly, with slope 1, from  $\alpha_1$  to  $\alpha_3$  and so on. Writing down where the slope changes gives us the divisor

$$\alpha_1 - \alpha_3 - \alpha_4 + \beta_2 + \beta_3 - \beta_5.$$

Doing the same for the  $y$ -coordinate, gives us the divisor

$$\alpha_1 - \alpha_3 - \alpha_4 - \beta_1 + \beta_3 + \beta_4.$$

The  $\alpha$ -hexagon is contained in the  $x = y$  plane, so it makes sense that the first three terms of each divisor are identical. However, this presents a problem because we need the lifting theorem to choose lifts for us on a break-divisor and we don't have any points we can allow the lifting theorem to choose for us on the  $\alpha$ -cycle.

We also need to consider the infinite rays. For example, at  $\alpha_2$  we have a ray going straight up (direction:  $(0, 1, 0)$ ) and then branching in the directions  $(-1, 0, 0)$ ,  $(0, -1, 0)$  and  $(1, 1, 1)$ . Thus we have two rays that have a non-zero  $x$ -coordinate and two rays that have a non-zero  $y$ -coordinate. Therefore, we need to lift  $\alpha_2$  to  $x_{2,0} - x_{2,1}$  and  $x_{2,0} - x_{2,2}$  for



the  $x$  and  $y$  coordinates respectively.

### 2.7.2 A proper construction

In order to construct this embedding properly, we first need to choose 4 points  $\gamma_1, \dots, \gamma_4$  spaced equidistant between two previously marked points, let's say  $\omega$  and  $\alpha_1$  and another four points  $\delta_1, \dots, \delta_4$  spaced equidistant between  $\beta_1$  and  $\beta_2$ . These points provide for us break-divisors which we can feed into Theorem 2.2.2. These points are also pictured in Figure 2.11.

As in section 2.2, we apply Theorem 2.2.2 to the data of Table 2.2 where the break divisors are the sum of the circled quantities. This yields three piecewise-linear function  $F_1, F_2, F_3$  from the extended skeleton to  $\mathbf{TP}^1$ .

Table 2.2: Divisors on  $\Gamma$  and on  $X^{\text{an}}$ . Lifts are chosen first for  $D_1$ , then  $D_2$ , then  $D_3$ .

$\tau_*D_1$	$D_1$	$\tau_*D_2$	$D_2$	$\tau_*D_3$	$D_3$
$+\alpha_1$	$\textcircled{x_1}$	$+\alpha_1$	$x_1$	$+\alpha_1$	$x_1$
	$x_{2,0} - x_{2,1}$		$x_{2,0} - x_{2,2}$	$+\alpha_2$	$x_{2,0}$
$-\alpha_3$	$-x_{3,1}$	$-\alpha_3$	$-x_{3,2}$	$-\alpha_4$	$-x_{4,3}$
$-\alpha_4$	$-x_{4,1}$	$-\alpha_4$	$-x_{4,2}$	$-\alpha_5$	$-\textcircled{x_5}$
$+\beta_2$	$\textcircled{y_{2,0}}$	$-\beta_1$	$-\textcircled{y_1}$		$y_{2,0} - y_{2,3}$
$+\beta_3$	$y_{3,0}$		$y_{2,0} - y_{2,2}$		$y_{3,0} - y_{3,3}$
	$y_{4,0} - y_{4,1}$	$+\beta_3$	$y_{3,0}$		$y_{4,0} - y_{4,3}$
$-\beta_5$	$-y_5$	$+\beta_4$	$y_{4,0}$		$u_{2,0} - u_{2,3}$
	$u_{2,0} - u_{2,1}$	$-\gamma_1$	$-\textcircled{u_1}$		$u_{3,0} - u_{3,3}$
	$u_{3,0} - u_{3,1}$	$+\gamma_2$	$u_{2,0}$	$-\delta_1$	$-\textcircled{v_1}$
	$v_{2,0} - v_{2,1}$	$+\gamma_3$	$u_{3,0}$	$+\delta_2$	$v_{2,0}$
	$v_{3,0} - v_{3,1}$	$-\gamma_4$	$-u_4$	$+\delta_3$	$v_{3,0}$
			$v_{2,0} - v_{2,2}$	$-\delta_4$	$-v_4$
			$v_{3,0} - v_{3,2}$		

Here the notation for the lifts is as follows:

- $x$ 's correspond to  $\alpha$ 's,  $y$ 's to  $\beta$ 's,  $u$ 's to  $\gamma$ 's and  $v$ 's to  $\delta$ 's
- lifts with a single subscript are the unique lift of that point in  $X^{\text{an}}$  (and this lift is consistent for each divisor)

- for a lift with two subscripts, e.g.  $x_{i,j}$ , the first subscript represents the index of the corresponding point of  $\Gamma$  (so  $x_{i,j}$  is a lift of  $\alpha_i$ ). The second subscript corresponds to which divisor the lift is for (e.g.  $x_{i,j}$  is a lift for  $D_j$ ). If the second subscript is 0, the lift appears in all three of  $D_1, D_2, D_3$  (and again, the lift is consistent).

We choose multiple lifts of the same point of  $\Gamma$  in order to ensure the resulting tropicalization is “injective at infinity” i.e. we have an embedding in  $\mathbf{TP}^3$ . This is achieved by choosing the lifts in such a way that all the infinite rays have directions  $(-1, 0, 0)$ ,  $(0, -1, 0)$ ,  $(0, 0, -1)$  or  $(1, 1, 1)$ .

Having done this, we need to ensure smoothness, and this requires us to choose the lifts over a point  $p$  to share a common initial segment of length  $\ell(p)$  as in Figure 2.12.

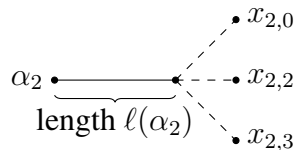

Figure 2.12:  $\alpha_2$  and its lifts (dashed lines are infinite).

**Proposition 2.7.1.** *The data in Table 2.2 allows us, via Theorem 2.2.2, to find rational functions  $f_1, f_2, f_3$  on  $X^{\text{an}}$  whose divisors are  $D_1, D_2, D_3$  and such that  $\text{div}(\log |f_i|) = \tau_* D_i$  for all  $i$ . As before, we let  $F = (F_1, F_2, F_3)$ .*

*For convenience, we will assume that  $F(v) = (0, 0, 0)$ .* □

### 2.7.3 Injective, smooth and fully-faithful

The goal of this section is to explain why this construction is smooth and fully-faithful and how to choose the appropriate parameters to make the construction injective.

First, we will explain how the picture we started with (Figure 2.10) does not have any crossings. After that, we will explain how to choose the data corresponding to  $\gamma_1, \dots, \gamma_4, \delta_1, \dots, \delta_4$  to get an injective lift.

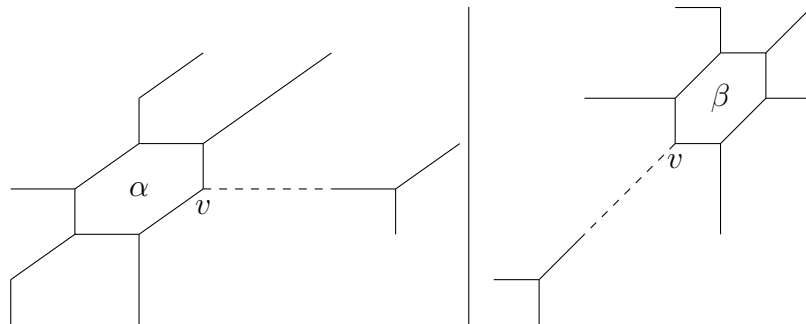

Figure 2.13: The  $x = y$  and  $z = 0$  planes in our construction. Dashed lines represent where the other hexagons are (outside the planes).

The following Proposition is included for completeness, to show that we have a crossing-free tropical variety in Figure 2.10. If the reader is sufficiently convinced by the image in Figure 2.10, they may prefer to continue reading the proof in Proposition 2.7.3.

**Proposition 2.7.2.** *The rough draft in Figure 2.10 does not contain any crossings.*

*Proof.* To start: the two hexagons do not cross each other because they are separated by the plane  $x + y = 0$ .

Second, the rays starting at the hexagons do not cross the hexagons. These rays can all be separated by a plane that contains one of the edges of the hexagon at the vertex where the ray originates.

Also, the rays starting at the hexagons do not intersect other such rays. We can see this in Figure 2.13 or by writing down the rays.

For example, the rays of the  $\beta$  hexagon have  $z = 0$  and do not have a chance of intersecting most of the rays of the  $\alpha$  hexagon. If we extend the lines of the  $\beta$  hexagon to infinity in Figure 2.13, they separate all the rays, including the one ray of the  $\alpha$  hexagon.

Lastly, we have all the infinite rays that branch off of another ray. Let us first consider those rays in the direction  $(-1, 0, 0)$ . Of course, none of these rays will intersect each other because they are parallel.

Neither will they intersect the rays in the direction  $(0, -1, 0)$  since every ray in the direction  $(-1, 0, 0)$  lies on one side of the plane  $x = y$  and every ray in the direction

$(0, -1, 0)$  on the other.

Nor will they intersect the hexagons or the rays coming off of the hexagons which we can see by examining the position of each of the rays with respect to the planes  $x = y$ ,  $z = 0$  or  $x + y = 0$ . Figure 2.13 gives some insight to this.

For example, at  $\alpha_2$ , the ray in the  $(-1, 0, 0)$  direction has  $z > 0$  and  $x \leq y$ . So it will not intersect anything with  $z \leq 0$ , nor anything with  $x > y$ , and it only intersects the plane  $x = y$  at one point. This excludes everything. In fact, by checking each ray, we see that these three planes ( $x = y$ ,  $z = 0$  and  $x + y = 0$ ) are enough to separate each ray.

The rays in the direction  $(0, -1, 0)$  are just the mirror image of those in the direction  $(-1, 0, 0)$  after reflecting in the  $x = y$  plane. So anything we said about the  $(-1, 0, 0)$ -rays holds for the  $(0, -1, 0)$  rays.

The story is the similar for the rays in the direction  $(1, 1, 1)$  and  $(0, 0, -1)$ . For example, rays in the direction  $(1, 1, 1)$  all start with  $z \geq 0$  and rays in the direction  $(0, 0, -1)$  all start with  $z \leq 0$ . So these types of rays don't intersect each other, nor the hexagons, nor the rays coming directly off of the hexagons.

Finally, there is no intersection between infinite rays in any direction as we can see by checking the position with respect to various planes at each ray. Namely, the planes  $x = y$ ,  $z = 0$ ,  $x + y = 0$  work. □

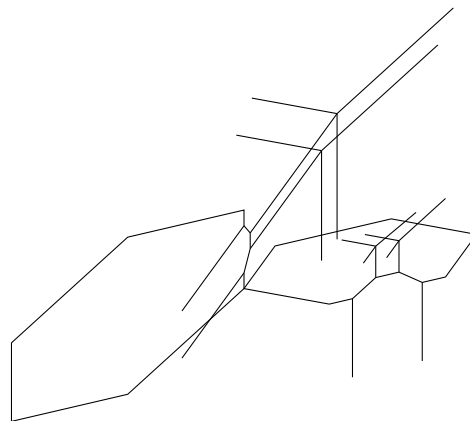

Figure 2.14: Position of the new rays added from the rough draft.

Now let us look at the construction in Table 2.2 which has some extra bits added to it, pictured in Figure 2.14. The bumps at  $\delta_1, \dots, \delta_4$  and  $\gamma_1, \dots, \gamma_4$  are small enough that they should not impact injectivity. But we can also make the bumps arbitrarily small if we are concerned by decreasing the distances between  $\delta_1$  and  $\delta_2$  and between  $\gamma_1$  and  $\gamma_2$ .

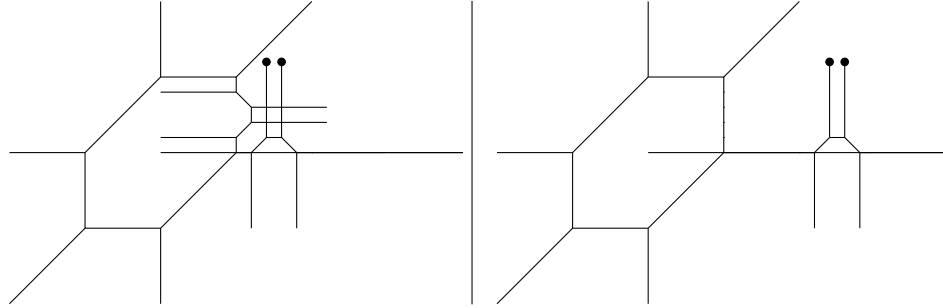

Figure 2.15: Where the rays in  $-x$  and  $-y$  direction originate at  $\gamma_2, \gamma_3$ . Projection onto the  $x = 0$  and  $y = 0$  planes.

The idea, which one can see in Figure 2.15, is that there is some compact set (possibly even finite) of lengths that would cause an intersection and outside which, all other lengths work.

**Proposition 2.7.3.** *We can choose the lengths  $\ell(\delta_2), \ell(\delta_3), \ell(\gamma_2), \ell(\gamma_3)$  to get an injective embedding of our curve.*

*Proof.* First, project onto the plane  $z = 0$ . Here you can see that the infinite rays at  $\delta_1, \delta_4$  do not intersect any part of the rough draft.

Similarly, in the projection onto  $x = 0$ , we can see that the rays at  $\gamma_1, \gamma_4$  do not intersect any part of the rough draft.

Now, consider the finite rays at  $\delta_2, \delta_3$ . These point in the  $+y$  direction and, in fact, all other rays that point in the  $+y$  direction are finite. Meaning if  $\ell(\delta_2)$  and  $\ell(\delta_3)$  are large enough, then there are no more rays parallel to the  $\delta_2$  and  $\delta_3$  rays.

Therefore, after a certain threshold, when we start three infinite rays in the directions  $(-1, 0, 0), (0, 0, -1)$  and  $(1, 1, 1)$ , there are only finitely many lengths that would cause an intersection with any part of the rough draft.

On the other hand, the ray at  $\delta_3$  going in the  $-z$  direction will intersect the finite ray at  $\delta_2$  if  $\ell(\delta_3) \leq \ell(\delta_2)$ . If we assert that  $\ell(\delta_2) < \ell(\delta_3)$ , there are no issues.

For the rays at  $\gamma_2, \gamma_3$ , it is the same picture: a bounded set of lengths that would cause an intersection, afterwards the only issue is that the ray in the  $(1, 1, 1)$  direction at  $\gamma_2$  might intersect the finite ray at  $\gamma_3$ . So again, we assert that  $\ell(\gamma_3) < \ell(\gamma_2)$ .

By construction, the infinite rays have directions  $(-1, 0, 0)$ ,  $(0, -1, 0)$ ,  $(0, 0, -1)$  or  $(1, 1, 1)$ . It is easy to see that rays in these directions intersect at infinity in  $\mathbf{TP}^3$  if and only if they intersect in  $\mathbf{R}^3$ . □

Proposition 2.7.3 is the hard part. Afterwards, smoothness and fully-faithfulness come for free from how we constructed the rough draft.

**Proposition 2.7.4.** *If we choose the lengths  $\ell(\delta_2), \ell(\delta_3), \ell(\gamma_2), \ell(\gamma_3)$  such that the tropicalization is injective it is also smooth and fully faithful.*

*Proof.* Since the map is injective, and along each edge the gcd of the slopes of the functions  $F_1, F_2, F_3$  is 1 (by construction), thus the weight of every edge is 1. Therefore, the map is fully-faithful.

For smoothness (which is also by construction), we simply have to check all the vertices. For example, at  $\alpha_1$  the outgoing directions are, according to Table 2.2,

- $(1, 1, 1)$  along the ray towards infinity,
- $(0, 0, -1)$  along the ray towards  $v$ ,
- $(-1, -1, 0)$  along the ray towards  $\alpha_2$ .

The lattice spanned by these three rays is  $\{(x, y, z) \in \mathbf{Z}^3 \mid x - y = 0\}$ . This is clearly of rank 2 and saturated.

At  $v$ , the rays are

$(0, 0, 1)$  along the ray towards  $\gamma_1$ ,

$(0, 1, 0)$  along the ray towards  $\beta_1$ ,

$(1, 0, 0)$  along the ray towards  $\beta_5$ ,

$(-1, -1, -1)$  along the ray towards  $\alpha_5$ .

The lattice spanned here is  $\mathbf{Z}^3$ .

All other vertices can be checked similarly. Therefore, the tropicalization is smooth.  $\square$

## **Part II**

# **Multiplicities over Hyperfields**



## CHAPTER 3

### TROPICAL EXTENSIONS AND BAKER-LORSCHIED MULTIPLICITIES FOR IDYLLS

Let  $P$  be a polynomial over a field  $K$ , where  $K$  has some additional structure like an absolute value or a total order. Two classical problems are determining the relationship between the absolute values or the signs of the coefficients and those of the roots. Newton's rule describes the relationship between a non-Archimedean valuation of the coefficients and of the roots. Descartes's rule describes the number of positive roots or negative roots with respect to the pattern of signs of the coefficients.

Recently, Matthew Baker and Oliver Lorscheid [BL21a] put these kinds of questions into a common framework known as hyperfields, which are algebras<sup>1</sup> which capture the arithmetic of signs or of absolute values. For instance,  $\mathbf{S} := \mathbf{R}/\mathbf{R}_{>0} = \{[0], [1], [-1]\}$  is the hyperfield of signs. Multiplication and addition in  $\mathbf{S}$  come from the quotient. I.e.  $[a][b] = [ab]$  and addition of equivalence classes is given by  $\sum[a_i] = \{[\sum a'_i] : a'_i \in [a_i]\}$ . For example,  $[1] + [1] = \{[1]\}$  and  $[1] + [-1] = \{[0], [1], [-1]\}$ .

Let us look at some example questions which Baker and Lorscheid's framework addresses.

**Example 3.0.1.** Consider the polynomial

$$F(x) = (x + 3)(x - 4)(x - 6) = 2^3 \cdot 3^2 - 2 \cdot 3x - 7x^2 + x^3.$$

The sign sequence of the coefficients is  $+, -, -, +$  and the signs of the roots are  $-, +, +$ . Descartes's rule of signs says that after removing any zeroes from the coefficient sequence, the number of positive roots we should expect is equal to the number of adjacent pairs of

---

<sup>1</sup>The term "algebra" is used in this chapter in the broad sense of a set with some distinguished elements, operations and relations.

opposite signs in the coefficient sequence.

For the number of negative roots, we look at  $F(-x)$ . So if there are no zero coefficients, then the number of negative roots we expect is equal to the number of adjacent pairs of identical signs in the coefficient sequence. Moreover, this bound is sharp so long as all the roots are real.

Baker and Lorscheid consider this question over the hyperfield of signs. Specifically, if we take the polynomial  $f = [1] + [-1]x + [-1]x^2 + [1]x^3$  over the hyperfield of signs, then their multiplicity operator (3.0.13) gives  $\text{mult}_{[1]}^{\mathbf{S}}(f) = 2$  and  $\text{mult}_{[-1]}^{\mathbf{S}}(f) = 1$ .  $\diamond$

**Example 3.0.2.** Next, consider the same polynomial but with the 2-adic or 3-adic valuation. Here we make a scatter plot of  $(c, v_p(c))$  for each coefficient  $c$  and  $p \in \{2, 3\}$  and then take the lower convex hull as shown in Figure 3.1.

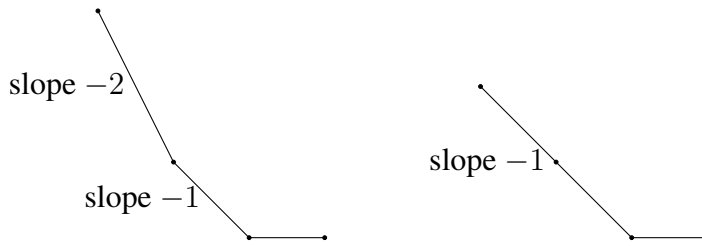

Figure 3.1: Newton polygons of  $(x + 3)(x - 4)(x - 6)$  in  $\mathbb{Q}_2$  and  $\mathbb{Q}_3$  respectively

Newton's Polygon Rule says that the number of roots  $r$  with  $v_p(r) = k$  is equal to the horizontal width the edge with slope  $-k$  (i.e. its length after projecting to the  $x$ -axis). Thus, for  $p = 2$ , the valuations of the roots are 0, 1, 2 and for  $p = 3$  they are 0, 1, 1.

Likewise, if we consider the polynomials  $3 + 1x + 0x^2 + 0x^3$  and  $2 + 1x + 0x^2 + 0x^3$  over the tropical hyperfield ( $\mathbf{T}$ ), Baker and Lorscheid's multiplicity operator,  $\text{mult}^{\mathbf{T}}$ , gives the numbers above. For example,  $\text{mult}_1^{\mathbf{T}}(2 + 1x + 0x^2 + 0x^3) = 2$ .  $\diamond$

In this chapter, we will look at how their multiplicity operator works in the context of a tropical extension. The most common and natural examples of tropical extension are as follows: take  $K/G$  to be a hyperfield coming from a quotient, and form a field of series over  $K$  (e.g. Laurent or Puiseux series). Then quotient by the group of series whose leading

coefficient belongs to  $G$ . For example, if the hyperfield is  $\mathbf{R}/\mathbf{R}_{>0}$ , then the equivalence classes in this tropical extension are  $[0]$  and  $\{[\pm t^n] : n \in \Gamma\}$ , where the ordered group  $\Gamma$  depends on what sort of series we use. Arithmetic in this hyperfield is a combination of the arithmetic of signs and of non-Archimedean absolute values and is described in detail in [Gun22a].

We also address so-called *stringent* hyperfields—a term introduced by Nathan Bowler and Ting Su [BS21]. A hyperfield is stringent if  $a \boxplus b$  is a singleton whenever  $a \neq -b$ . Stringent hyperfields are the next simplest form of hyperfields after fields. We show that for a polynomial over a stringent hyperfield, the sum of the multiplicities of all roots is bounded by the polynomial’s degree (Corollary 3.E).

### 3.0.1 Structure of the chapter and a rough statement of the results

In this chapter, the primary type of algebra are *idylls*—a generalization of fields which consists of a monoid  $B^\bullet$  describing multiplication and a proper ideal  $N_B \subseteq \mathbf{N}[B^\bullet]$  describing addition. To describe these algebras, it will be convenient to talk about the larger category of ordered blueprints introduced by Lorscheid [Lor18c; Lor18a; Lor12; Lor18b; Lor15] which describe addition through a preorder on  $\mathbf{N}[B^\bullet]$ . An Euler diagram of the relationships between these categories is show in Figure 3.2.

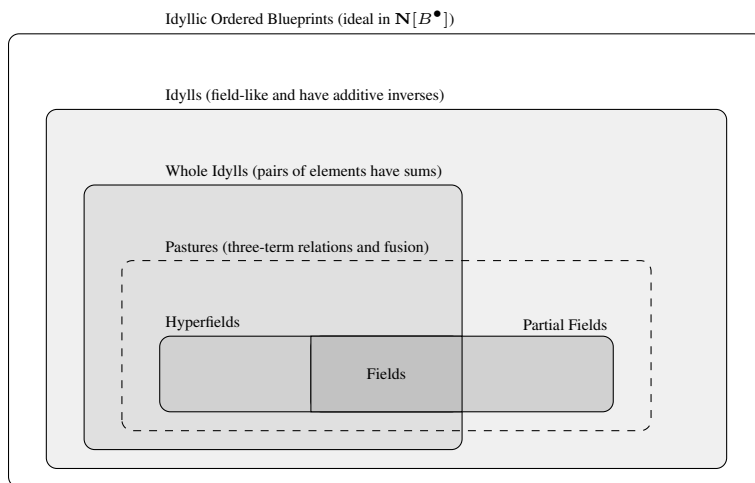

Figure 3.2: Euler diagram of relationships between sub-categories of ordered blueprints

We will first state some rough definitions and results here, giving as many definitions as we reasonably can. A more thorough description of ordered blueprints and idylls is given in section 3.1. In section 3.2, we define polynomial extensions and tropical extensions and discuss Newton polygons and initial forms. In section 3.3, we finish describing the theory of polynomials and multiplicities, factorization and multiplicities. In section 3.4, we show that tropical extensions for hyperfields (after Bowler and Su [BS21]) are a special case of tropical extensions of idylls. In section 3.5, we prove Theorems A, B, C which concern initial forms and lifting. In section 3.6, we give some examples and corollaries connecting this work to previous results and prove Theorem D and Corollary E concerning the degree bound. In Appendix A, we record some division algorithms which have appeared in [BL21a], [Gun22a] and [AL21].

Let us begin with a description of an *ordered blueprint*. This is an algebraic structure consisting of two parts: a multiplicative and additive structure. Multiplication is defined by a monoid  $(B^\bullet, 0_B, 1_B, \cdot_B)$  with identity  $1_B$  and an absorbing element  $0_B$ . The additive structure is defined by an additive and multiplicative preorder among formal sums over  $B^\bullet$  [Lor15].

Within the category of ordered blueprints, one has what are named here *idyllic* ordered blueprints, for which this preorder is entirely described by an ideal  $N_B := \{\sum a_i \in \mathbf{N}[B^\bullet] : 0 \leq \sum a_i\}$ . The category of idyllic ordered blueprints is, morally speaking, the smallest category containing hyperfields, partial fields, and polynomial extensions. We work entirely within this category, and often within the sub-subcategory of field-like objects which we call idylls.

**Definition 3.0.3.** An *idyll*  $B$ , is a pair  $(B^\bullet, N_B)$ , which consists of a monoid  $B^\bullet = (B^\bullet, 0_B, 1_B, \cdot_B)$  together with a proper ideal  $N_B$  of  $\mathbf{N}[B^\bullet]$ , which is “field-like” in the sense that:

- $0_B \neq 1_B$ ,

- $B^\times := B^\bullet \setminus \{0_B\}$  is a group,
- there exists a unique  $\epsilon_B \in B^\bullet$  such that  $\epsilon_B^2 = 1$  and  $1 + \epsilon_B \in N_B$ .

$N_B$  is called the *null-ideal* of  $B$  and  $B^\bullet$  and  $B^\times$  are called the *underlying monoid* and *group of units*, respectively.

A first example of an idyll is the idyll associated to a field.

**Example 3.0.4.** Let  $K$  be a field and let  $K^\bullet = (K, 0_K, 1_K, \cdot_K)$  be the multiplicative monoid of  $K$ . Then we can define  $N_K$  as the ideal of all formal sums whose evaluation in  $K$  is 0. ◇

Next, we have the idylls associated to the rules of Descartes and Newton. More examples of idylls will be given in section 3.1.

**Example 3.0.5.** The *idyll of signs* or *sign idyll*,  $\mathbf{S}$ , has underlying monoid  $\mathbf{S}^\bullet = \{0, 1, -1\}$  with the standard multiplication. The null-ideal of  $\mathbf{S}$  is the set consisting of the empty sum, together with all formal sums that include at least one 1 and at least one  $-1$ . In other words, a formal sum of signs  $\sum s_i$  is in  $N_{\mathbf{S}}$  if and only if there exists real numbers  $x_i$  such that  $\text{sign}(x_i) = s_i$  and  $\sum x_i = 0$  in  $\mathbf{R}$ . ◇

**Example 3.0.6.** The *tropical idyll*,  $\mathbf{T}$ , is the idyll whose underlying monoid is  $(\mathbf{R} \cup \{\infty\}, \infty, 0, +)$ , where  $\infty$  is an absorbing element for the monoid. The null-ideal,  $N_{\mathbf{T}}$ , is the set of all formal sums where the minimum term (in the usual ordering) appears at least twice in the sum. In other words, a formal sum of valuations  $\sum \gamma_i$  is in  $N_{\mathbf{T}}$  if and only if there is a valued field  $(K, v)$  containing elements  $x_i$  such that  $v(x_i) = \gamma_i$  and  $\sum x_i = 0$  in  $K$ .

More generally, to every ordered abelian group  $\Gamma$ , we associate an idyll  $\Gamma^{\text{idyll}}$  by the same construction. For instance,  $\mathbf{T} = \mathbf{R}^{\text{idyll}}$ . ◇

We now introduce the concept of a *tropical extension*. The classical analogue of this is to take a field  $K$  and form the field of Laurent series or Puiseux series in  $t$  over  $K$ . This

gives us a  $t$ -adic valuation where the residue field is  $K$ . Likewise, we are here forming a larger idyll with a valuation and whose “residue idyll” is the idyll we start with. We leave some categorical constructions to subsection 3.1.3.

**Definition 3.0.7.** If  $B$  is an idyll with multiplicative group  $B^\times$ , then a *tropical extension* of an ordered Abelian group  $\Gamma$  by  $B$  is an idyll  $C$  with some additional properties. First, there are morphisms  $B \xrightarrow{\iota} C \xrightarrow{v} \Gamma^{\text{idyll}}$  which induce a short exact sequence of groups:

$$1 \rightarrow B^\times \xrightarrow{\iota^\bullet} C^\times \xrightarrow{v^\bullet} \Gamma \rightarrow 1.$$

Second, the exactness of the sequence of groups must extend to the ordered blueprints, i.e.  $\text{im}(\iota) = \text{eq}(v, 1)$ . Lastly, we require that  $N_C$  has the property that  $\sum c_i \in N_C$  if and only if  $\sum_I c_i \in N_C$ , where  $I = \{i : v^\bullet(c_i) \text{ is minimal}\}$ .

With a slight abuse of notation, we will write  $C \in \text{Ext}^1(\Gamma, B)$  to mean that  $C$  is a tropical extension of  $\Gamma$  by  $B$ .

**Remark 3.0.8.** *Tropical extensions appear in the work of Akian, Gaubert, and Guterman for semirings with a symmetry (negation) [AGG14] as well as in the work of Rowan concerning the more general setting of “semiring systems” [Row22].*

*For (skew) hyperfields, tropical extensions appear in the work of Bowler and Su as a semidirect product [BS21]. Some examples of this are as follows.*

**Example 3.0.9.** The most basic example of a tropical extension is the tropical idyll itself, which fits into an exact sequence

$$1 \rightarrow \mathbf{K}^\times \rightarrow \mathbf{T}^\times \xrightarrow{\sim} \mathbf{R} \rightarrow 1. \quad \diamond$$

**Example 3.0.10.** More generally, let  $\mathbf{T}_m = (\mathbf{R}^m, \leq_{\text{lex}})^{\text{idyll}}$  be the rank- $m$  tropical idyll, which is defined the same way as  $\mathbf{T}$  but using  $(\mathbf{R}^m, \leq_{\text{lex}})$  in place of  $(\mathbf{R}, \leq)$ . For all  $m, n$ ,

we have a tropical extension

$$1 \rightarrow \mathbf{T}_m^\times \rightarrow \mathbf{T}_{m+n}^\times \rightarrow \mathbf{R}^n \rightarrow 1. \quad \diamond$$

**Example 3.0.11.** The tropical real idyll,  $\mathbf{TR}$ , is the extension

$$1 \rightarrow \mathbf{S}^\times \rightarrow \mathbf{TR}^\times \rightarrow \mathbf{R} \rightarrow 1.$$

Here  $\mathbf{TR}^\bullet = \{\pm t^\gamma : \gamma \in \mathbf{R}\} \cup \{0\}$  with multiplication given by  $s_1 t^{\gamma_1} \cdot s_2 t^{\gamma_2} = (s_1 s_2) t^{\gamma_1 + \gamma_2}$  where  $s_i \in \{\pm 1\}$  are signs that multiply in the usual way.

The null-ideal,  $N_{\mathbf{TR}}$ , is the set of all formal sums  $\sum s_i t^{\gamma_i}$  such that if  $I = \{i : \gamma_i \text{ is minimal}\}$  then  $\sum_I s_i \in N_{\mathbf{S}}$ . I.e. among the coefficients  $\{s_i : i \in I\}$ , there is at least one  $+1$  and at least one  $-1$ . The tropical real idyll is described further in [Gun22a].  $\diamond$

Similar to tropical extensions, we can define polynomial extensions over idylls and define a recursive multiplicity operator for roots of these polynomials.

**Definition 3.0.12.** We say that  $f$  factors into  $(x - a)g$  if  $f - (x - a)g$  belongs to the null ideal of  $B[x]$ . This is equivalent to saying that the degree  $d$  terms of  $f - (x - a)g$  belong to  $x^d N_B$  for all  $d$ .

We have the following definition of a multiplicity operator for idylls, which appears as Definition 1.5 of [BL21a] for polynomials over hyperfields.

**Definition 3.0.13.** Let  $B$  be an idyll, let  $f \in B[x]$  be a polynomial and let  $a \in B^\bullet$ . The *multiplicity of  $f$  at  $a$*  is

$$\text{mult}_a^B(f) = 1 + \max \text{mult}_a^B(g),$$

where the maximum is taken over all factorizations of  $f$  into  $(x - a)g$ , or  $\text{mult}_a^B(f) = 0$  if there are no such factorizations.

We will define a generalization of leading coefficients and initial forms for tropical extensions. Specifically, we generalize two operators from the classical setting. First,

if  $c = \sum a_i t^i \in \mathbf{C}((t))^\times$  is a nonzero Laurent series, then  $\text{lc}^\bullet(c) = a_{i_0} \in \mathbf{C}$ , where  $i_0 = \min\{i : a_i \neq 0\}$ . Second, if  $f = \sum c_i x^i \in \mathbf{C}((t))[x]$  and  $w \in \mathbf{Z}$ , then  $\text{in}_w(f) = \sum_I \text{lc}^\bullet(c_i) x^i \in \mathbf{C}[x]$ , where  $I = \{i : v_t(c_i) + iw \text{ is minimal}\}$  and  $v_t : \mathbf{C}((t)) \rightarrow \mathbf{Z} \cup \{\infty\}$  is the  $t$ -adic valuation.

For the main theorems, we need one more axiom. We define a *whole idyll* to be an idyll for which every pair of elements  $a, b \in B^\bullet$  has at least one ‘sum’  $c \in B^\bullet$  for which  $a + b - c \in N_B$ . The class of whole idylls includes fields and hyperfields, but excludes partial-fields which are not themselves fields. Additionally, let us be clear that a ‘polynomial’ in this chapter is not allowed to have multiple terms with the same degree, so  $x + x^2 + x^5$  is a polynomial but  $x + x + x$  is not.

With this in mind, the main theorem for split extensions (having a splitting  $\Gamma \rightarrow C^\times, \gamma \mapsto t^\gamma$ ) is the following.

**Theorem 3.A.** *Let  $B$  be a whole idyll and let  $C = B[\Gamma]$  be a split tropical extension of  $\Gamma$  by  $B$ . Then for every polynomial  $f \in C[x]$  and  $a \in C^\bullet$  with valuation  $\gamma$ ,*

$$\text{mult}_a^C(f) = \text{mult}_{\text{lc}^\bullet(a)}^B(\text{in}_\gamma(f)).$$

With some slight modification to the ideas of initial forms, we extend this result to the non-split case as follows.

**Theorem 3.B.** *Let  $B$  be a whole idyll and let  $C \in \text{Ext}^1(\Gamma, B)$  be a tropical extension of  $\Gamma$  by  $B$ . Let  $f \in C[x]$  be a polynomial and let  $a \in C^\bullet$  be a root of  $f$ . Then*

$$\text{mult}_a^C(f) = \text{mult}_{\text{lc}^\bullet(a)}^B(\text{in}_a(f)).$$

In proving this theorem, we will show the following result. Notation is the same as in the previous theorem.



**Theorem 3.C.** Any factorization of  $\text{in}_a f$  into  $(x - 1)g$  can be lifted to a factorization of  $f$  into  $(x - a)\tilde{g}$  such that  $\text{in}_a \tilde{g} = g$ .

**Example 3.0.14.** If  $f$  is a tropical polynomial, then its multiplicity at  $w \in \mathbf{T}^\times$  is the same as the multiplicity of the initial form  $\text{in}_w f$ , and we will see in Example A.0.1 that this is the horizontal length of the edge in the Newton polygon of  $f$  with slope  $-w$ , as described in Example 3.0.2.  $\diamond$

This example shows how one of Baker and Lorscheid's theorems [BL21a, Theorem D] is a special case of ours, and this will also provide an alternative proof of their theorem which we will see in section 3.6.

**Example 3.0.15.** The ordinary generating function of the Catalan numbers satisfies the equation  $f(C) = 1 - C + xC^2 = 0$ . This is a polynomial in  $C$  with coefficients in  $\mathbf{R}[x] \subset \mathbf{R}((x))$ . The two initial forms of  $f$  are  $\text{in}_0 f = 1 - C$  and  $\text{in}_{-1} f = -C + C^2 = -C(1 - C)$ .

The initial form  $\text{in}_0 f$  has one positive root, and therefore Theorem 3.A tells us to expect one positive root with valuation 0. Likewise,  $\text{in}_{-1} f = -C + C^2$  has one positive root and therefore we should also expect one positive root with valuation  $-1$ . This all agrees with the explicit solutions we can compute:

$$C_1 = 1 + x + 2x^2 + 5x^3 + \dots, C_2 = \frac{1}{x} - 1 - x - 2x^2 - \dots. \quad \diamond$$

In section 3.6, we show that tropical extension preserves the property of having the sum of multiplicities be bounded by  $\deg f$  for all polynomials  $f \in B[x]$ . This gives some partial understanding to a question asked by Baker and Lorscheid about which hyperfields have this property.

**Definition 3.0.16.** We say that a whole idyll  $B$  satisfies the degree bound if for every polynomial  $f \in B[x]$ ,

$$\sum_{b \in B^\bullet} \text{mult}_b^B f \leq \deg f.$$

**Theorem 3.D.** *If  $B$  satisfies the degree bound and  $C \in \text{Ext}^1(\Gamma, B)$ , then  $C$  satisfies the degree bound.*

Finally, Bowler and Su have a classification of stringent hyperfields [BS21, Theorem 4.10]. A hyperfield is *stringent* if every sum  $a \boxplus b$  is a singleton unless  $b = -a$ . Bowler and Su’s classification says that a hyperfield is stringent if and only if it is a tropical extension of a field, of  $\mathbf{K}$ , or of  $\mathbf{S}$ . This gives us the following corollary.

**Corollary 3.E.** *Every stringent hyperfield satisfies the degree bound.*

By [BL21a, Proposition B], a corollary of this degree bound is that if  $\varphi : K \rightarrow C$  is a morphism from a field  $K$  to  $C$ , then

$$\text{mult}_c^C f = \sum_{a \in \varphi^{-1}(c)} \text{mult}_a^K F$$

for all polynomials  $f \in C[x]$ . In particular, this is true for every stringent hyperfield (Corollary 3.6.5).

### 3.0.2 Relationship to other papers

There are two papers which have a close relationship with this chapter. First is the author’s previous paper [Gun22a], which proves Theorems 3.A and 3.C but only for the real tropical hyperfield  $\mathbf{TR} = \mathbf{S}[\mathbf{R}]$ . The current chapter was developed in the editing and revision process for that paper and generalizes the previous paper.

Specifically, here we consider tropical extensions of any rank as well as extensions of any (whole) idyll, not just the extension  $\mathbf{S} \rightarrow \mathbf{TR}$ . Theorems 3.A, 3.B, 3.C generalize one of the main theorems of this previous paper [Gun22a, Theorem A]. Theorem 3.D and Corollary 3.E are entirely new to this chapter. On the other hand, there are a few things covered in the first paper but not in the current chapter:

1. The first paper spends more time discussing properties of  $\mathbf{TR}$  and what it means to

have a morphism from a field  $K$  to  $\mathbb{T}\mathbb{R}$  (i.e. to have a compatible valuation and total order on  $K$ ) [Gun22a, Section 2.2.1].

2. The first paper gives a proof of the multiplicity formula for fields with a morphism to  $\mathbb{T}\mathbb{R}$  in the language of fields—in particular without using the result for the hyperfield  $\mathbb{T}\mathbb{R}$  [Gun22a, Section 3].
3. There is a weak lifting theorem given a polynomial over  $\mathbb{T}\mathbb{R}$  to a polynomial over the field of Hahn series  $\mathbb{R}[[t^{\mathbb{R}}]]$  having the same number of roots whose leading coefficient is real and positive [Gun22a, Theorem 5.4].

The second paper that has close similarities is that of Marianne Akian, Stéphane Gaubert and Hanieh Tavakolipour [AGT23]. They also consider more general tropical extensions than just  $\mathbb{S} \rightarrow \mathbb{T}\mathbb{R}$ . In their paper, they work with a class of algebras introduced by Rowan, called *semiring systems* [Row22]. These bear some similarities to ordered blueprints, but the translation is opaque. Akian, Gaubert and Rowan give some comments about the differences and similarities [AGR22, Section 5.1], but no direct translation has yet been described. Both frameworks have interest, as well as different connections and potential future development.

Within Rowan’s framework, Akian, Gaubert, and Tavakolipour prove a version of Theorems 3.A and 3.B using similar techniques (initial forms) [AGT23, Theorem 5.11]. Their paper also greatly extends the weak lifting theorem [Gun22a, Theorem 5.4] by proving that multiplicities over semiring systems analogous to the idylls  $\mathbb{S}[\Gamma]$  can be lifted to any real closed field [AGT23, Theorem 7.8] (and the roots are real rather than just having a series whose leading coefficient is real).

### 3.0.3 Acknowledgements

I thank the anonymous reviewer of the previous paper for their comments. I thank Matt Baker for his suggestions and support in finishing this paper. I thank Oliver Lorscheid for corrections and other helpful comments. I thank James Maxwell for some discussion of an

early draft of this paper. I thank Marianne Akian, Stéphane Gaubert and Hanieh Tavakolipour for explaining some of the literature on semirings with a symmetry and semiring systems, as well as other helpful comments.

I again thank all the people who talked with me about the ideas in the previous paper and/or for suggesting edits: Matt Baker, Marcel Celaya, Tim Duff, Oliver Lorscheid, Yoav Len and Josephine Yu.

### 3.1 Idylls and Ordered Blueprints

Several interrelated ring-like and field-like algebraic theories have been used as a framework for  $\mathbf{F}_1$  geometry [Lor18a], matroid theory [BB19; BL21b], and polynomial multiplicities [BL21a] among other uses. One such field-like algebra is a *hyperfield*, wherein the sum of two elements is a nonempty set. Hyperfields have a lot of axioms which largely mirror their classical counterparts and these are described in [BL21a] as well as the author's previous paper [Gun22a].

In this chapter, we work with a generalization of fields and hyperfields called *idylls*, which also have simpler axioms than their hyperfield counterparts. To start, fix a monoid  $B^\bullet$  which one can think of as generalizing the multiplicative structure of a ring.

**Definition 3.1.1.** For us, monoids have two distinguished elements: 0 and 1, and the following axioms:

- multiplication is commutative and associative,
- 1 is a unit:  $1 \cdot x = x$  for all  $x$ ,
- 0 is absorbing:  $0 \cdot x = 0$  for all  $x$ .

These are also called *pointed monoids* or *monoids-with-zero* in the literature.

Second, we form the free semiring,  $\mathbf{N}[B^\bullet]$ , which is a quotient of the semiring of finitely

supported formal sums by the ideal  $\langle 0 \rangle$ . I.e.

$$\mathbf{N}[B^\bullet] := \frac{\{\sum_{i=1}^n x_i : x_i \in B^\bullet\}}{\{0, 0 + 0, 0 + 0 + 0, \dots\}}.$$

**Definition 3.0.3.** An *idyll*  $B$ , is a pair  $(B^\bullet, N_B)$ , which consists of a monoid  $B^\bullet = (B^\bullet, 0_B, 1_B, \cdot_B)$  together with a proper ideal  $N_B$  of  $\mathbf{N}[B^\bullet]$ , which is “field-like” in the sense that:

- $0_B \neq 1_B$ ,
- $B^\times := B^\bullet \setminus \{0_B\}$  is a group,
- there exists a unique  $\epsilon_B \in B^\bullet$  such that  $\epsilon_B^2 = 1$  and  $1 + \epsilon_B \in N_B$ .

$N_B$  is called the *null-ideal* of  $B$  and  $B^\bullet$  and  $B^\times$  are called the *underlying monoid* and *group of units*, respectively.

**Remark 3.1.2.** For some purposes, it is enough to just assume that  $N_B$  is closed under multiplication by elements in  $B^\bullet$  rather than requiring it to be an ideal. Such algebras are called *tracts* and are used, for instance, in the work of Baker and Bowler on matroids [BB19].

### 3.1.1 Ordered Blueprints

One reason to prefer the stronger notion of idylls is because these are special cases of Oliver Lorscheid’s theory of ordered blueprints [Lor18c; Lor18a; Lor12; Lor18b; Lor15]. We can think about these null-ideals as a “1-sided relation”  $0 \leq x_1 + \dots + x_n$  where we say which sums should be “null” (although this does not mean we are considering the quotient by  $N_B$ ). Ordered blueprints expand this 1-sided relation by allowing any preorder on  $\mathbf{N}[B^\bullet]$  which is closed under multiplication and addition. The next definition makes this precise.

**Definition 3.1.3.** An *ordered blueprint*  $B = (B^\bullet, \leq)$  consists of an underlying monoid  $B^\bullet$  and a preorder or *subaddition*  $\leq$  on  $\mathbf{N}[B^\bullet]$  satisfying for all  $a, b \in B^\bullet$  and  $w, x, y, z \in \mathbf{N}[B^\bullet]$

- $a \leq a$  (reflexive on  $B^\bullet$ )
- $a \leq b$  and  $b \leq a$  implies  $a = b$  (antisymmetric on  $B^\bullet$ )
- $x \leq y$  and  $y \leq z$  implies  $x \leq z$  (transitive)
- $x \leq y$  implies  $x + z \leq y + z$  (additive)
- $w \leq x$  and  $y \leq z$  implies  $wy \leq xz$  (multiplicative)
- $0 \leq (\text{empty sum})$  and  $(\text{empty sum}) \leq 0$

The notation  $x \in B$  means  $x \in \mathbf{N}[B^\bullet]$ .

**Remark 3.1.4.** *The relation  $\leq$  is only necessarily antisymmetric on  $B^\bullet$ . If we identify all formal sums  $x, y \in \mathbf{N}[B^\bullet]$  such that  $x \leq y$  and  $y \leq x$ , the quotient is a new semiring which is denoted  $B^+$ . The subaddition  $\leq$  descends to a partial order (antisymmetric) on  $B^+$  [Lor18c, Section 5.4].*

*An equivalent theory of ordered blueprints can be described in terms of a partial order on a semiring  $B^+$  which is generated by  $B^\bullet$ —meaning  $B^+$  is a quotient of  $\mathbf{N}[B^\bullet]$ . In this chapter, most of our generating relations will be of the form  $0 \leq y$  so our preorders will usually be partial orders as well.*

*Baker and Lorscheid define idylls as a partial order on  $B^+$  and take as an axiom that the quotient map  $\mathbf{N}[B^\bullet] \rightarrow B^+$  is a bijection [BL21b, Definition 2.18]. Since idylls are the primary class of objects for us, we will work with  $\mathbf{N}[B^\bullet]$  directly.*

**Definition 3.1.5.** We say that a preorder is *generated* by a collection  $S = \{x_i \leq y_i : i \in I\}$  if it is the smallest preorder containing  $S$ .

**Remark 3.1.6.** *There is a natural embedding of the category of idylls in the category of ordered blueprints by letting  $\leq$  be the preorder generated by  $0 \leq \sum a_i$  for every  $\sum a_i \in N_B$ . We will use both ideal and preorder notation in what follows.*

We can also generalize idylls to a larger (but still proper) subcategory of ordered blueprints. If idylls are field-like then *idyllic* ordered blueprints are their ring-like cousins. We do not assume that idyllic ordered blueprints have additive inverses for the sole reason that it allows us to call  $\mathbf{F}_1$ —which we will define shortly—an idyllic blueprint.

**Definition 3.1.7.** An ordered blueprint is *idyllic* if it is generated by relations of the form  $0 \leq \sum x_i$ . The *idyllic part* of an ordered blueprint  $B$ , is an ordered blueprint  $B^{\text{idyll}}$  obtained by restricting to the relation generated by relations of the form  $0 \leq \sum x_i$  in  $B$ . We will sometimes drop the word “ordered” to be less wordy and simply call these “idyllic blueprints.”

If  $B$  is idyllic, we will again call  $N_B = \{\sum x_i \in \mathbf{N}[B^\bullet] : 0 \leq \sum x_i\}$  the *null-ideal* of  $B$  and call  $\leq$  a *subaddition*. This gives us a common language to talk about idylls and idyllic blueprints.

**Remark 3.1.8.** *There are other notions of positivity for ordered blueprints. In the language of a partial order on a semiring  $B^+$  (Remark 3.1.4), an ordered blueprint is purely positive if it is generated by relations of the form  $0 \leq \sum x_i$  [BL21b, Definition 2.18]. In this language, an idyllic ordered blueprint is a purely positive ordered blueprint for which the map  $\mathbf{N}[B^\bullet] \rightarrow B^+$  is a bijection.*

**Remark 3.1.9.** *There are two ways to embed a ring or a field  $R$  into the category of ordered blueprints. For both embeddings, the underlying monoid is  $R^\bullet = (R, 0_R, 1_R, \cdot_R)$ . First, we can embed  $R$  as  $R^{\text{oblpr}}$  where the relation is given by  $\sum x_i \leq \sum y_i$  if the evaluation of those sums in  $R$  are equal. The second embedding is  $R^{\text{idyll}} = (R^{\text{oblpr}})^{\text{idyll}}$ , where we restrict to relations of the form  $0 \leq \sum y_i$ .*

In other words, there is one embedding into the category of ordered blueprints and a different embedding into the category of idyllic blueprints.

**Example 3.1.10.** The ordered blueprint  $\mathbf{F}_1$  has  $\mathbf{F}_1^\bullet = \{0, 1\}$  as its underlying monoid, with the usual multiplication. The relation on  $\mathbf{F}_1$  is equality (equivalently it has an empty

generating set).  $\mathbf{F}_1$  is the initial object in the category of idyllic ordered blueprints and its null-ideal is  $\{0\}$ .  $\diamond$

**Example 3.1.11.** The *Krasner idyll*  $\mathbf{K}$  on  $\{0, 1\}$  is the idyll with null-ideal  $\mathbf{N}[\mathbf{B}^\bullet] \setminus \{1\} = \{1 + 1, 1 + 1 + 1, \dots\}$ . The Krasner idyll is the terminal object in the category of idylls.  $\diamond$

**Definition 3.1.12.** If  $R$  is a ring or field and  $G$  is a subgroup of  $R^\times$ , then there is an idyll on  $G^\bullet = G \cup \{0\}$  which we call a *partial field idyll*. The null-ideal of  $G$  is the set of formal sums whose image in  $R$  is zero.

These are called “partial” fields because the sum of two elements of  $G^\bullet$  may or may not be in  $G^\bullet$  as well. Therefore addition is only partially defined.

**Example 3.1.13.** If  $G = \{1, -1\} = \mathbf{Z}^\times$  then  $N_G = \langle 1 + (-1) \rangle$ . This is called the regular partial field (idyll) and is denoted either  $\mathbf{F}_{1^2}$  or  $\mathbf{F}_1^\pm$  in the literature.

More generally, if  $G = \mu_n \subset \mathbf{C}^\times$  is the group of  $n$ -th roots of unity, then  $G$  forms an idyllic ordered blueprint called  $\mathbf{F}_{1^n}$ . This lacks additive inverses if  $n$  is odd, but is still field-like.  $\diamond$

**Definition 3.1.14.** If  $K$  is a field and  $G$  is a subgroup of  $K^\times$  then there is an idyll on  $K/G$  called a *hyperfield idyll*. The null-ideal  $N_{K/G}$  is the set of sums of equivalence classes  $[a_1] + \dots + [a_n]$  for which there exists representatives  $x_i \in [a_i], i = 1, \dots, n$  for which  $x_1 + \dots + x_n = 0$  in  $K$ .

**Remark 3.1.15.** *Partial fields and hyperfields are also thought about in terms of the sum sets  $a \boxplus b := \{c : a + b - c \in N_B\}$ . For partial fields, every sum is either empty or a singleton. For hyperfields, every sum is non-empty. Fields, therefore, are the intersection of partial fields and hyperfields.*

**Remark 3.1.16.** *All of the hyperfield (idyll)s named in this chapter are quotients of some field by a multiplicative group, however there are hyperfields which are not of this form.*



Christos Massouros was the first to construct an example of such [Mas85]. For the purposes of this chapter, it is sufficient to think only about quotient hyperfields.

For quotients, the sum sets defined in the previous remark can also be defined for an arbitrary number of summands by

$$\bigsqcup_i [a_i] = \{a'_i : a'_i \in [a_i]\}.$$

If the hyperfield is not a quotient, then we need to define repeated hyperaddition monadically:

- identify  $a$  with  $\{a\}$ ,
- flatten sums, so

$$a_0 \boxplus (a_1 \boxplus \cdots \boxplus a_n) = \bigcup \{a_0 \boxplus t : t \in a_1 \boxplus \cdots \boxplus a_n\}.$$

Defining hyperfields as idylls (Definition 3.4.1) skips having to talk about the monadic laws.

The monadic laws are closely related to a fissure rule (Remark 3.3.6) for pastures, which we will define later on. We will also reference the monadic laws in section 3.4 where we define hyperfields as special kinds of pastures.

**Example 3.1.17.** As an example, the Krasner idyll  $\mathbf{K}$  is a quotient  $K/K^\times$  for any field  $K$  other than  $\mathbf{F}_2$ . The idyll of signs  $\mathbf{S}$  is the quotient  $\mathbf{R}/\mathbf{R}_{>0}$ . The tropical idyll is the quotient of a valued field  $K$  with value group  $\mathbf{R}$  by the group of elements with valuation 0.

More generally, if the value group of  $K$  is any ordered Abelian group  $\Gamma$ , then the same quotient  $K/v^{-1}(0)$  gives an idyll structure on  $\Gamma$  which we will see again in Definition 3.1.25. This is a tropical idyll but not *the* tropical idyll—a term reserved for  $\Gamma = \mathbf{R}$ . Instead, we will call these *OAG idylls*. ◇

**Example 3.1.18.** The *idyll of phases* or *phase idyll*  $\mathbf{P}$ , is the hyperfield idyll on the quotient  $\mathbf{C}/\mathbf{R}_{>0}$ . A sum of phases  $\sum e^{i\theta_k}$  belongs to  $N_{\mathbf{P}}$  if there are magnitudes  $a_k \in \mathbf{R}_{>0}$  for which

$\sum a_k e^{i\theta_k} = 0$ . Equivalently, we can define the null-ideal using convex hulls as

$$N_{\mathbf{P}} = \left\{ \sum_k e^{i\theta_k} : 0 \in \text{int} \left( \text{conv}_k(e^{i\theta_k}) \right) \right\},$$

where  $\text{int}(\text{conv}_k(e^{i\theta_k}))$  is the interior of the convex hull relative to its dimension. E.g. if the convex hull is a line segment, then the interior is a line segment without the endpoints.  $\diamond$

**Remark 3.1.19.** *As Bowler and Su point out in a footnote [BS21, page 674], there are actually two phase idylls/hyperfields: the quotient  $\mathbf{P} = \mathbf{C}/\mathbf{R}_{>0}$  as defined above, and the one that Viro originally defined [Vir10]. The difference is in whether you require 0 be in the interior of  $\text{conv}_k(e^{i\theta_k})$  (our definition) or if it is allowed to lie on the boundary (Viro's definition).*

### 3.1.2 Morphisms of Ordered Blueprints

**Definition 3.1.20.** If  $B, C$  are two ordered blueprints, a (homo)morphism  $f : B \rightarrow C$  consists of a morphism of monoids  $f^\bullet : B^\bullet \rightarrow C^\bullet$  such that the induced map  $f : B \rightarrow C$  is order-preserving. In particular, for all  $x, y, x_i, y_i \in B^\bullet$

- $f^\bullet(xy) = f^\bullet(x)f^\bullet(y)$
- $f^\bullet(0_B) = 0_C$
- $f^\bullet(1_B) = 1_C$
- if  $\sum x_i \leq \sum y_i$  then  $f(\sum x_i) \leq f(\sum y_i)$

**Definition 3.1.21.** A morphism of idylls is a morphism of their corresponding ordered blueprints. I.e. it is a morphism of monoids such that  $f(N_B) \subseteq N_C$ .

#### Valuations

Classically, a (rank-1) valuation on a field  $K$  is a map  $v : K \rightarrow \mathbf{R} \cup \{\infty\}$  such that

- $v(0) = \infty$ ,
- $v$  restricts to a group homomorphism  $F^\times \rightarrow (\mathbf{R}, +)$ ,
- and for every  $a, b \in F$ , we have  $v(a + b) \geq \min\{v(a), v(b)\}$ .

In our language, a valuation in this sense is simply a morphism from a field  $K$  (viewed as an idyll) to the tropical idyll  $\mathbf{T}$ .

We can also substitute  $\mathbf{R}$  with any ordered Abelian group (OAG).

**Definition 3.1.22.** An *ordered Abelian group* (OAG) is an Abelian group  $(\Gamma, +)$  with a total order  $\leq$  for which  $a \leq b$  implies  $a + c \leq b + c$  for all  $a, b, c$ .

**Example 3.1.23.** On  $\mathbf{R}^n$ , there is a *lexicographic* or *dictionary* order  $\leq_{\text{lex}}$  defined inductively by  $(a_1, \dots, a_n) \leq_{\text{lex}} (b_1, \dots, b_n)$  if either  $a_1 < b_1$  or  $a_1 = b_1$  and  $(a_2, \dots, a_n) \leq_{\text{lex}} (b_2, \dots, b_n)$ . We will make use of this order in subsection 3.2.2  $\diamond$

**Definition 3.1.24.** The *rank* of an OAG  $\Gamma$ , is the smallest number  $n$  such that  $\Gamma$  admits an order-preserving embedding in  $(\mathbf{R}^n, \leq_{\text{lex}})$ . The term “higher-rank” means any rank greater than 1.

**Definition 3.1.25.** The idyll  $\Gamma^{\text{idyll}}$  is the idyll on  $\Gamma^\bullet = \Gamma \cup \{\infty\}$  where

- $\infty$  is the absorbing element
- 0 is the unit element (writing things additively)
- $\sum a_i \in N_\Gamma$  if and only if the minimum term appears at least twice

We will call this an *OAG idyll*.

**Definition 3.1.26.** In our framework, a *valuation*  $v$  on an idyllic ordered blueprint  $B$ , is a morphism  $v : B \rightarrow \Gamma^{\text{idyll}}$  for some ordered Abelian group  $\Gamma$ . The letter  $v$  will be reserved for a valuation of some kind and usually for the valuation  $C \rightarrow \Gamma^{\text{idyll}}$  which appears in the definition of a tropical extension.

Now we will check that valuations as we have just defined, agree with the usual notion of a Krull valuation as well as illustrate some properties of valuations.

**Proposition 3.1.27.** *If  $R$  is a ring and  $v : R^{\text{idyll}} \rightarrow \Gamma^{\text{idyll}}$  is a valuation, then*

(V1)  $v^\bullet : R^\bullet \rightarrow \Gamma^\bullet$  is a monoid homomorphism,

(V2)  $v^\bullet(0_R) = \infty$ ,

(V3) if  $u^n = 1_R$  for some  $n \geq 1$  then  $v^\bullet(u) = 0$ ,

(V4)  $v^\bullet(a +_R b) \geq \min\{v^\bullet(a), v^\bullet(b)\}$  for all  $a, b \in R$ .

(V5) if  $v^\bullet(a) \neq v^\bullet(b)$  then  $v^\bullet(a +_R b) = \min\{v^\bullet(a), v^\bullet(b)\}$ .

Conversely, a map  $v^\bullet : R^\bullet \rightarrow \Gamma^\bullet$  with these properties induces a valuation  $v : R^{\text{idyll}} \rightarrow \Gamma^{\text{idyll}}$ .

*Proof.* Properties (V1) and (V2) follow by definition and Property (V3) follows from Property (V1).

For Property (V4), if  $c = a +_R b$  in  $R$ , then  $0 \leq_R a + b - c$  in  $R^{\text{idyll}}$ . Therefore,  $v(a + b - c) = v^\bullet(a) + v^\bullet(b) + v^\bullet(c) \in N_\Gamma$  and this, by definition, means that the minimum of  $v^\bullet(a), v^\bullet(b), v^\bullet(c)$  occurs at least twice. It is impossible therefore, to have  $v^\bullet(c) < \min\{v^\bullet(a), v^\bullet(b)\}$ .

Property (V5) follows because if the minimum of  $v^\bullet(a), v^\bullet(b), v^\bullet(a +_R b)$  needs to occur at least twice and  $v^\bullet(a) \neq v^\bullet(b)$ , then  $v^\bullet(a +_R b)$  must be equal to the minimum of  $v^\bullet(a), v^\bullet(b)$ .

Conversely, suppose  $v^\bullet$  satisfies these properties and  $0 \leq \sum x_i$  in  $R^{\text{idyll}}$ —meaning  $\sum_R x_i = 0_R$  in  $R$  and we may assume that at least one of the  $x_i$ 's are nonzero or else there is nothing to show. Given this, we know that the minimum of the quantities  $v^\bullet(x_i)$  occurs at least twice because otherwise  $v^\bullet(\sum_R x_i) = \min v^\bullet(x_i)$  by property (V5). But  $v^\bullet(\sum_R x_i) = v^\bullet(0_R) = \infty \neq \min\{v^\bullet(x_i)\}$ . So we conclude that the minimum occurs at least twice and hence  $0 \leq \sum v^\bullet(x_i)$  in  $\Gamma^{\text{idyll}}$ .  $\square$

**Remark 3.1.28.** *A more general definition of valuations exists where the source and target can be any ordered blueprint [Lor15, Section 3], [Lor18c, Chapter 6].*

### 3.1.3 Images, Equalizers and Subblueprints

We will now define a few categorical constructions which are useful in our constructions—particularly for describing tropical extensions.

**Definition 3.1.29.** *A subblueprint  $B$  of an ordered blueprint  $C$  is a submonoid  $B^\bullet \subseteq C^\bullet$ , such that if  $\sum x_i \leq \sum y_i$  in  $B$  then  $\sum x_i \leq \sum y_i$  in  $C$ . The subblueprint is *full* if the converse holds: if  $\sum x_i$  and  $\sum y_i \in B$  then  $\sum x_i \leq \sum y_i$  in  $C$  if and only if  $\sum x_i \leq \sum y_i$  in  $B$ .*

**Remark 3.1.30.** *A full subblueprint is determined entirely by the submonoid  $B^\bullet \subseteq C^\bullet$  and we will call this an induced subblueprint.*

**Definition 3.1.31.** *If  $f : B \rightarrow C$  is a morphism of ordered blueprints, its *image* is the subblueprint  $\text{im}(f)$  on the monoid  $\text{im}(f)^\bullet = f(B^\bullet) \subseteq C^\bullet$ , where  $\sum f^\bullet(x_i) \leq \sum f^\bullet(y_i)$  in  $\text{im}(f)$  if and only if  $\sum x_i \leq \sum y_i$  in  $B$ .*

**Definition 3.1.32.** *Given two maps  $f, g : B \rightarrow C$ , their *equalizer*,  $\text{eq}(f, g)$ , is the induced subblueprint of  $B$  on  $\text{eq}(f, g)^\bullet = \{x \in B^\bullet : f(x) = g(x)\}$ .*

**Definition 3.1.33.** *If  $v : C \rightarrow \Gamma^{\text{idyll}}$  is a valuation on an idyll  $C$ , we define a morphism  $1 : C \rightarrow \Gamma^{\text{idyll}}$  by  $1^\bullet(x) = 1_{\Gamma^{\text{idyll}}}$  if  $x \neq 0_C$  and  $1^\bullet(0_C) = 0_{\Gamma^{\text{idyll}}}$ . This is a morphism because idylls have proper null-ideals, meaning if  $\sum x_i \in N_C$  then there are at least two nonzero  $x_i$ 's, and so  $1(\sum x_i) \in N_\Gamma$  since the minimum occurs at least twice.*

We can also describe the morphism  $1$  as the composition of the sequence  $C \xrightarrow{v} \Gamma^{\text{idyll}} \rightarrow \mathbf{K} \rightarrow \Gamma^{\text{idyll}}$ .

### 3.2 Polynomial and Tropical Extensions

Let us turn our attention next to generalizing polynomial rings to polynomials over idylls. Remember that additive relations in idylls are encoded by an ideal in some free semiring. The terms in those additive relations form a monoid. This suggests the following definition.

**Definition 3.2.1.** Let  $B$  be an idyll with monoid  $B^\bullet$  and null-ideal  $N_B \subset \mathbf{N}[B^\bullet]$ . The *polynomial extension* of  $B$  is an idyllic ordered blueprint, which we call  $B[x]$ . Its underlying monoid is

$$B[x]^\bullet = \{bx^n : b \in B^\bullet, n \in \mathbf{N}\} / \langle 0x^n \equiv 0 : n \in \mathbf{N} \rangle$$

with multiplication given by  $(bx^m)(cx^n) = (bc)x^{m+n}$ . The null-ideal of  $B[x]$  is the ideal in  $\mathbf{N}[B[x]^\bullet]$  which is generated by  $N_B$ .

**Definition 3.2.2.** When we say a *polynomial*, we mean that which might otherwise be called a *pure polynomial*. A (pure) polynomial is an element of  $\mathbf{N}[B[x]^\bullet]$  for which there is at most one term in each degree. E.g.  $x + x^2 + x^5$  is a polynomial but  $x + x + x$  is not.

**Remark 3.2.3.** *The idea to use ordered blueprints as a framework for polynomial algebras was mentioned in Baker and Lorscheid's work [BL21a, Appendix A]. The ordered blueprint construction rectifies some shortcomings that arise from trying to create algebras over hyperfields naively such as failing to be associative or free.*

A related construction to polynomial extensions is that of a split tropical extension.

**Definition 3.2.4.** Let  $B$  be an idyll and let  $\Gamma$  be an OAG. Form the pointed group

$$B[\Gamma]^\bullet = \{bt^\gamma : b \in B^\bullet, \gamma \in \Gamma\} / \langle 0t^\gamma \equiv 0 : \gamma \in \Gamma \rangle$$

with multiplication given by  $(b_1t^{\gamma_1})(b_2t^{\gamma_2}) = (b_1b_2)t^{\gamma_1\gamma_2}$ .

The null-ideal of  $B[\Gamma]$  is the set of all formal sums  $\sum a_i t^{\gamma_i}$  such that if we let  $I = \{i : \gamma_i \text{ is minimum}\}$  then  $\sum_I a_i \in N_B$ .

Split tropical extensions come with a natural valuation map  $v : B[\Gamma] \rightarrow \Gamma^{\text{idyll}}$  given by  $v^\bullet(bt^\gamma) = \gamma$ . For split tropical extensions, there is a splitting  $\Gamma \rightarrow B[\Gamma]^\times$  given by  $\gamma \mapsto t^\gamma$ .

**Remark 3.2.5.** *Going forward, we will often drop the ‘t’ from the notation and simply write  $b^\gamma$  instead of  $bt^\gamma$  and  $1^\gamma$  instead of  $t^\gamma$ . This helps avoid confusing  $B[\Gamma]$  with a polynomial extension since  $B[\Gamma]$  has some additional relations on it beyond those of just polynomials.*

More generally, a tropical extension is any idyll which fits into an exact sequence with  $B$  and  $\Gamma$  and with similar rules about the null-ideal as for split extensions.

**Definition 3.0.7.** If  $B$  is an idyll with multiplicative group  $B^\times$ , then a *tropical extension* of an ordered Abelian group  $\Gamma$  by  $B$  is an idyll  $C$  with some additional properties. First, there are morphisms  $B \xrightarrow{\iota} C \xrightarrow{v} \Gamma^{\text{idyll}}$  which induce a short exact sequence of groups:

$$1 \rightarrow B^\times \xrightarrow{\iota^\bullet} C^\times \xrightarrow{v^\bullet} \Gamma \rightarrow 1.$$

Second, the exactness of the sequence of groups must extend to the ordered blueprints, i.e.  $\text{im}(\iota) = \text{eq}(v, 1)$ . Lastly, we require that  $N_C$  has the property that  $\sum c_i \in N_C$  if and only if  $\sum_I c_i \in N_C$ , where  $I = \{i : v^\bullet(c_i) \text{ is minimal}\}$ .

With a slight abuse of notation, we will write  $C \in \text{Ext}^1(\Gamma, B)$  to mean that  $C$  is a tropical extension of  $\Gamma$  by  $B$ .

**Remark 3.2.6.** *From subsection 3.1.3, to say that  $\text{im}(\iota) = \text{eq}(v, 1)$  means that  $0 \leq \sum x_i$  in  $B$  if and only if  $0 \leq \sum \iota^\bullet(x_i)$  in  $\text{eq}(v, 1) \subseteq C$ . I.e.  $\text{im}(\iota)$  is a full subblueprint of  $C$ . Because of this, we can safely make the assumption that  $B^\bullet \subseteq C^\bullet$  and  $\iota$  is the identity.*

**Remark 3.2.7.** *Tropical extensions of idylls are closely related to tropical extensions for semiring with a symmetry [AGG14] or for semiring systems [Row22; AGT23]. For hypergroups and (skew) hyperfields, tropical extensions appear as a semidirect product in the work of Bowler and Su [BS21].*

**Remark 3.2.8.** Tropical extensions have “levels”  $B^\gamma = \{c \in C : v^\bullet(c) = \gamma\}$ , which are not-necessarily-canonically isomorphic to  $B^\times$ , and  $B^0$  which is canonically isomorphic to  $B^\times$ . The relations on  $B^\gamma$  are uniquely determined by the torsor action  $B^0 \times B^\gamma \rightarrow B^\gamma$ . (See also subsection 3.2.2.)

Additionally, to say that a relation  $\sum a_i \in N_C$  holds if and only if it holds among the minimal valuation terms, means that if we have a sum like  $a - a \in N_C$  then  $a - a + b \in N_C$  for any element  $b$  of larger valuation. In other words, the sum set  $a \boxplus (-a)$  from Remark 3.1.15 contains every element whose valuation is strictly larger than  $v^\bullet(a)$ .

These properties about levels and sum sets are the basis for how Bowler and Su describe their semidirect product. We will give a formal proof of this equivalence in section 3.4.

**Remark 3.2.9.** By Bowler and Su’s classification [BS21, Theorem 4.17], if  $B$  is either  $\mathbf{K}$  or  $\mathbf{S}$  then every tropical extension by  $B$  is split.

**Example 3.2.10.** The tropical idyll  $\mathbf{T} = \mathbf{K}[\mathbf{R}]$  is a split tropical extension of  $\mathbf{R}$  by  $\mathbf{K}$ . The only caveat is a slight change of notation: we defined elements of  $\mathbf{T}^\times$  as real numbers but we defined elements of  $\mathbf{K}[\mathbf{R}]^\times$  as being of the form  $1^\gamma$  where  $\gamma$  is a real number.

For instance, the sum  $0 + 0 + 1$  in  $N_{\mathbf{T}}$  corresponds to  $1^0 + 1^0 + 1^1$  in  $\mathbf{K}[\mathbf{R}]$ . This is in  $N_{\mathbf{K}[\mathbf{R}]}$  because if we take the sum of the coefficients of the minimum terms, we get  $1 + 1 \in N_{\mathbf{K}}$ . ◇

**Example 3.2.11.** Every OAG idyll is a tropical extension in a natural way:  $\Gamma^{\text{idyll}} = \mathbf{K}[\Gamma]$  (again with a change of notation). For example, we have higher-rank tropical idylls such as  $\mathbf{T}_n := (\mathbf{R}^n, \leq_{\text{lex}})^{\text{idyll}} = \mathbf{K}[\mathbf{R}^n]$ . Moreover, there is a natural isomorphism  $\mathbf{T}_m[\mathbf{R}^n] = \mathbf{T}_{m+n}$  (Example 3.0.9). ◇

**Example 3.2.12.** Extensions by  $\mathbf{S}$  give signed tropical extensions. For instance,  $\mathbf{TR} = \mathbf{S}[\mathbf{R}]$  is the tropical real idyll/hyperfield which was first introduced by Oleg Viro [Vir11].

The null-ideal of  $\mathbf{TR}$  is given by sums where the minimum terms appear at least twice and with at least one positive and one negative term among them. E.g.  $t + (-1)t + t^2$  has



one positive minimum term,  $t$ , and one negative minimum term,  $(-1)t$ .  $\diamond$

**Example 3.2.13.** Extensions by  $\mathbf{P}$  give phased tropical extensions. For example,  $\mathbf{TP} = \mathbf{TC} = \mathbf{P}[\mathbf{R}]$  is the tropical phase idyll or tropical complex idyll. This was also introduced as a hyperfield by Viro (*ibid.*).  $\diamond$

**Remark 3.2.14.** For the tropical reals, there is a map  $\text{sign} : \mathbf{TR} \rightarrow \mathbf{S}$  which gives the sign of the leading coefficient. It is tempting to think that  $\mathbf{TR}$  is isomorphic to the pullback

$$\begin{array}{ccc} \mathbf{S} \times_{\mathbf{K}} \mathbf{T} & \longrightarrow & \mathbf{S} \\ \downarrow & & \downarrow \\ \mathbf{T} & \longrightarrow & \mathbf{K} \end{array}$$

but this is not the case. In  $\mathbf{S} \times_{\mathbf{K}} \mathbf{T}$ , we have the relation  $0 \leq 1^0 + 1^0 + (-1)^1$  because its images in  $\mathbf{S}$  and  $\mathbf{T}$  are relations. However, this is not a relation in  $\mathbf{TR}$  since among the terms of minimal valuation, they are all positive.

See [Lor18c, Section 5.5] for a discussion of various (co)limits in the category of ordered blueprints.

### 3.2.1 Newton Polygons and Initial forms

#### *Newton Polygons*

Associated to polynomials over a tropical extension or over a valued field, is an object called the Newton polygon. To define this, we require a rank-1 valuation  $v : B \rightarrow \mathbf{T}$ .

**Definition 3.2.15.** We define a *lower inequality* on  $\mathbf{R}^2$  to be an inequality of the form  $\langle u, x \rangle \geq c$  for some  $c \in \mathbf{R}$  and some  $u$  is in the upper half plane:  $u \in \{(u_1, u_2) : u_2 \geq 0\}$ . Every lower inequality creates a halfspace  $H(u, c) = \{x : \langle u, x \rangle \geq c\}$ .

Given a set of points  $S \subset \mathbf{R}^2$ , its *Lower Convex Hull* is defined as the intersection of the halfspaces containing  $S$ , where  $u = (u_1, u_2)$  is in the upper half plane:

$$\text{LCH}(S) = \bigcap \{H(u, c) : S \subseteq H(u, c), u_2 \geq 0\}.$$

**Definition 3.2.16.** Let  $v : B \rightarrow \mathbf{T}$  be a valuation on  $B$  and let  $f \in B[x], f = \sum_I b_i x^i$  be a polynomial. The *Newton polygon* of  $f$  is

$$\text{Newt}(f) = \text{LCH}(\{(i, v^\bullet(b_i)) : i \in I\}).$$

Additionally, by an *edge* of the Newton polygon, we will always mean a bounded edge.

**Example 3.2.17.** Consider the polynomial  $f = 2 + 1x + 0x^2 + 0x^3 + 2x^4 + 1x^5 \in \mathbf{T}[x]$ , where  $v : \mathbf{T} \rightarrow \mathbf{T}$  is the identity. The Newton polygon of  $f$  is shown in Figure 3.3.  $\diamond$

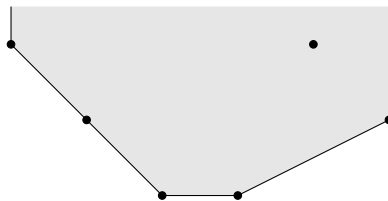

Figure 3.3: Newton polygon of  $f$  in Example 3.2.17

### 3.2.2 Initial Forms

Now we will define a “leading coefficient” and initial form operator for tropical extensions. First, for split extensions, we take the following definition.

**Definition 3.2.18.** For the split extension  $B[\Gamma]$ , define  $\text{lc}^\bullet : B[\Gamma]^\bullet \rightarrow B^\bullet$  by  $\text{lc}^\bullet(b^\gamma) = b$ .

This does not induce a morphism of ordered blueprints (c.f. Remark 3.2.14).

If  $\gamma \in \Gamma$ , define  $\text{in}_\gamma : B[\Gamma][x] \rightarrow B[x]$  by

$$\text{in}_\gamma \left( \sum b_i^{\gamma_i} x^i \right) = \sum_I \text{lc}^\bullet(b_i^{\gamma_i}) x^i$$

where  $I = \{i : \gamma_i + i\gamma \text{ is minimal}\}$ .

**Example 3.2.19.** Consider the polynomial  $f = 2 + 1x + 0x^2 + 0x^3 + 2x^4 + 1x^5 \in \mathbf{T}[x]$  from Example 3.2.17, whose Newton polygon is shown in Figure 3.3.

The Newton polygon of  $f$  has edges of slope  $-1, 0, \frac{1}{2}$  and the corresponding initial forms are  $\text{in}_1 f = 1 + x + x^2$ ,  $\text{in}_0 f = x^2 + x^3$  and  $\text{in}_{-1/2} f = x^3 + x^6 \in \mathbf{K}[x]$ . All other initial forms of  $f$  are monomials.  $\diamond$

### *Newton Polygons for Higher-Rank*

Consider a polynomial  $f = \sum b_i x^i$  with coefficients in  $\mathbf{T}_n = \mathbf{K}[\mathbf{R}^n] = (\mathbf{R}^n, \leq_{\text{lex}})^{\text{idyl}}$ , where  $\leq_{\text{lex}}$  is the lexicographic order from Example 3.1.23. Or, more generally, we could have coefficients in  $B$ , where  $B$  is equipped with a valuation  $v : B \rightarrow \mathbf{T}_n$ . In the previous section, we gave a definition of an initial form  $\text{in}_\gamma(f)$  which covers this, but the connection to Newton polygons is less clear. To figure out how to define this, we are going to consider a sequence of rank-1 valuations using the natural identity  $\mathbf{T}_n = \mathbf{T}_{n-1}[\mathbf{R}]$ .

Define  $v_n : \mathbf{T}_n \rightarrow \mathbf{T}$  as the valuation on  $\mathbf{T}_{n-1}[\mathbf{R}]$ . Explicitly, given  $\gamma = (\gamma_1, \dots, \gamma_n) \in (\mathbf{R}^n, \leq_{\text{lex}})$ , we have  $v_n(\gamma) = \gamma_1$ . Let  $\text{in}_\gamma^v$  denote the initial form operator with respect to an extension  $B[\Gamma] \xrightarrow{v} \Gamma$ . So, for example,  $\text{in}_{\gamma_1}^{v_n}$  means we are considering  $\mathbf{T}_n$  as an extension of  $\mathbf{R}$  by  $\mathbf{T}_{n-1}$  rather than as an extension of  $\mathbf{R}^n$  by  $\mathbf{T}_0 = \mathbf{K}$ . With this, we have the following lemma.

**Lemma 3.2.20.** *With the notation as above, we have*

$$\text{in}_\gamma^v(f) = \text{in}_{\gamma_n}^{v_1}(\dots \text{in}_{\gamma_2}^{v_{n-1}}(\text{in}_{\gamma_1}^{v_n}(f))).$$

Therefore, when we consider a higher-rank valuation, we are thinking about a sequence of Newton polygons rather than one Newton polytope.

*Proof.* This is an inductive statement, so to simplify notation, we will use  $n = 2$  to illustrate.

Let  $f = \sum (a_i, b_i)x^i \in \mathbf{T}_2[x]$  and let  $\gamma = (\lambda, \mu) \in \mathbf{T}_2^\times$ . Let  $I = \{i : (a_i, b_i) + i(\lambda, \mu) \text{ is minimal}\}$  and let that minimal value be  $(\lambda_0, \mu_0)$ . Next, let  $I_1 = \{i : a_i + i\lambda \text{ is minimal}\}$  and let that minimal value be  $\lambda'_0$ . First, we claim that  $\lambda'_0 = \lambda_0$ .

If not, then we must have  $\lambda'_0 < \lambda_0$  or else  $\lambda_0$  would be minimal minimal for  $I_1$  as well. Now if  $(\lambda_0, \mu_0) = (a_{i_0}, b_{i_0}) + i_0(\lambda, \mu)$  and  $\lambda'_0 = a_{i_1} + i_1\lambda$ , then by definition (Example 3.1.23), it must be that  $\lambda'_0 \geq \lambda_0$  or else  $(a_{i_1}, b_{i_1}) + i_1(\lambda, \mu) <_{\text{lex}} (\lambda_0, \mu_0)$  and this contradicts minimality.

Now define  $I_2 = \{i \in I_1 : b_i + i\mu \text{ is minimal}\}$ , and we have likewise that this minimal value is  $\mu_0$ . I.e. we have  $I_2 = I$ . Putting this together, we have

$$\text{in}_{(\lambda, \mu)}^v f = \sum_I x^i = \text{in}_{\mu}^{v_2} \left( \sum_{I_1} b_i x^i \right) = \text{in}_{\mu}^{v_2} (\text{in}_{\lambda}^{v_1}(f)). \quad \square$$

If the coefficients were in  $B[\mathbf{R}^n]$  rather than  $\mathbf{T}_n = \mathbf{K}[\mathbf{R}^n]$ , then everything works the same by changing notation from  $\sum \gamma_i x^i = \sum (\mathbf{1}_{\mathbf{K}})^{\gamma_i} x^i$  to  $\sum c_i^{\gamma_i} x^i$ .

**Remark 3.2.21.** *Lemma 3.2.20 demonstrates that we can apply Theorem 3.A inductively by considering a sequence of rank-1 extensions.*

### The Non-Split Case

If  $C \in \text{Ext}^1(\Gamma, B)$  is a non-split extension, then the leading coefficient map is no longer well defined because we can no longer simply divide by  $t^\gamma$ . Instead, for every fixed element  $c_0 \in C^\times$  with  $v^\bullet(c) = \gamma$ , we get a map  $\{c \in C^\times : v^\bullet(c) = \gamma\} \rightarrow B^\times$  by dividing by  $c_0$  and this map depends on the choice of  $c_0$ , i.e. this is a torsor for  $B^\times$ .

**Definition 3.2.22.** Let  $C \in \text{Ext}^1(\Gamma, B)$  be a tropical extension. Because the sequence  $B^\times \rightarrow C^\times \rightarrow \Gamma$  is exact, there is a natural identification of  $B^\times$  with the group  $B^0 := \{c \in C^\times : v^\bullet(c) = 0\}$ . More generally, let us define  $B^\gamma = \{c \in C^\times : v^\bullet(c) = \gamma\}$  and  $B^\infty = \{0_C\}$ . This gives a grading  $C^\bullet = \bigcup_{\gamma \in \Gamma} B^\gamma$  where multiplication is graded:  $\cdot : B^\gamma \times B^{\gamma'} \rightarrow B^{\gamma+\gamma'}$ . In particular, the pairing  $B^0 \times B^\gamma \rightarrow B^\gamma$  makes  $B^\gamma$  into a  $B^0$ -torsor.

We will define the leading coefficient map  $\text{lc}^\bullet : C^\bullet \rightarrow \bigcup_{\gamma \in \Gamma} B^\gamma$  which literally is the identity, but we give a name to this to keep the notation consistent. This also helps remind us that the output is in a specific torsor for  $B$ .

So now, instead of having initial forms with coefficients in  $B$ , the coefficients will be in one of these torsors.

**Definition 3.2.23.** Let  $C \in \text{Ext}^1(\Gamma, B)$  be a tropical extension and let  $f = \sum c_i x^i \in C[x]$  be a polynomial. Let  $a \in C$  be a root of  $f$  with valuation  $\gamma_1$  and let  $\gamma_0 = \min\{v^\bullet(c_i) + i\gamma_1\}$ . We will say that  $a$  corresponds to the line  $\ell = \{\gamma_0 - i\gamma_1 : i \in \mathbf{N}\}$ .

Let  $I = \{i : v^\bullet(c_i) = \gamma_0 - i\gamma_1\}$ . We define the initial form with respect to  $a$  (rather than with respect to  $\gamma_1$ ) as

$$\text{in}_a(f) = \sum_{i \in I} \text{lc}^\bullet(c_i)(ax)^i \in B^{\gamma_0}[x].$$

**Remark 3.2.24.** For split extensions, we have two initial forms. First, we have  $\text{in}_\gamma f \in B[x]$  from Definition 3.2.18. Second, we have  $\text{in}_a f \in B^{\gamma_0}[x]$  from Definition 3.2.23. These two polynomials are related via the natural identification  $B^\times = B^0$  and the identity

$$\text{in}_\gamma f = 1^{-\gamma_0} \text{in}_{1^\gamma} f.$$

Additionally, if  $a = b^\gamma$ , then

$$\text{in}_{b^\gamma} f(x) = \text{in}_{1^\gamma} f(bx).$$

### 3.3 Factoring Polynomials and Multiplicities over Idylls

We now investigate factoring and multiplicities. First, we will do this for  $B[x]$  and show that these notions are an extension to idylls of the Baker-Lorscheid multiplicity operator for hyperfields. Second, we will define this for  $B^{\gamma_0}[x]$  and we will see that all the ways to identify  $B^{\gamma_0} \cong B$  lead to the same multiplicities and factors.

#### 3.3.1 Roots of Polynomials

There are two serviceable definitions of what it means for a polynomial to have a root. Classically, we can say that  $f(x)$  has a root  $a$  if  $f(a) = 0$  or if  $(x - a) \mid f(x)$ . For idylls, we

will take the latter as the definition and explain in which context the two definitions agree.

**Definition 3.3.1.** Let  $f(x) = \sum_{i=0}^n c_i x^i$  be a polynomial over an idyll  $B$  and let  $a \in B^\bullet$ . We will say that  $a$  is a *root* of  $f$  if there exists a *factorization*  $0 \leq f(x) - (x - a)g(x)$  for some polynomial  $g(x) = \sum d_i x^i$ . I.e. if  $0 \leq c_i - d_{i-1} + ad_i$  for all  $i$  (treating the coefficients as infinite sequences with a finite support).

**Definition 3.3.2.** It will be convenient to define a relation  $\preceq$  by  $x \preceq y$  if  $0 \leq -x + y$ . So we will write factorizations as  $f(x) \preceq (x - a)g(x)$  and  $c_i \preceq d_{i-1} - ad_i$ .

There is a context in which Definition 3.3.1 is equivalent to  $0 \leq f(a)$ , called *pastures*. There are a few equivalent definitions of pastures in the literature, we give one of them here.

**Definition 3.3.3.** An ordered blueprint is *reversible* if it contains an element  $\epsilon = \epsilon_B$  such that  $\epsilon^2 = 1$ , we have the relation  $0 \leq 1 + \epsilon$ , and such that if  $a, b \in B^\bullet, x \in \mathbf{N}[B^\bullet]$  then  $a \leq b + x$  implies  $eb \leq \epsilon a + x$ . By [Lor18c, Lemma 5.6.34],  $\epsilon$  is unique and so is any additive inverse of  $a$  for any  $a \in B^\bullet$ . As with idylls, we will write  $-1$  and  $-a$  instead of  $\epsilon$  and  $\epsilon a$ .

A *pasture* is a reversible ordered blueprint generated by relations of the form  $a \leq b + c$  with  $a, b, c \in B^\times$  as well as the relation  $0 \leq 1 + (-1)$ .

**Remark 3.3.4.** If  $B$  is a pasture, its idyllic part  $B^{\text{idyll}}$  satisfies an axiom known as *fusion* where if  $a \in B^\bullet$  and  $x, y \in \mathbf{N}[B^\bullet]$  then  $0 \leq x + a$  and  $0 \leq y - a$  implies  $0 \leq x + y$ .

*Proof.* By reversibility,  $0 \leq x + a$  implies  $-a \leq x$  and  $0 \leq y - a$  implies  $a \leq y$ . Adding these together, we have

$$0 \leq (-a) + a \leq x + y. \quad \square$$

**Remark 3.3.5.** The fusion rule is discussed in detail in a paper of Baker and Zhang [BZ23]. It is possible to define a pasture as an idyll generated by three-term relations  $0 \leq a + b + c$  and fusion (the idyllic part of what we have just defined). Just looking at idylls generated by

three-term relations but without the fusion axiom gives a nonequivalent definition of pasture such as [BL21b, Definition 6.19].

**Remark 3.3.6.** *If  $B$  is a pasture, then we can break apart longer relations into three-term relations inductively. This procedure is known as fissure. If  $a_i \in B^\bullet$  and  $a_0 \leq a_1 + \dots + a_n$  then there exists a  $t \in B^\bullet$  for which  $a_0 \leq a_1 + t$  and  $t \leq a_2 + \dots + a_n$ . A consequence of fissure is that  $0 \leq a + b + c$  if and only if  $-a \leq b + c$ . A consequence of that consequence is that we can recover a pasture from its idyllic part.*

*Because of this, we can also view pastures as a subcategory of idylls. Moreover, the relation  $\preceq$  is the same as  $\leq$  for pastures.*

For pastures, the two definitions of “ $a$  is a root of  $f$ ” are equivalent. The proof of this is a translation of Lemma A in [BL21a] to the language of pastures.

**Proposition 3.3.7.** *If  $B$  is a pasture and  $f \in B[x]$  is a polynomial, then for any  $a \in B^\bullet$ ,  $0 \leq f(a)$  if and only if there exists a polynomial  $g \in B[x]$  for which  $f(x) \leq (x - a)g(x)$ .*

*Proof.* First, if  $a = 0$  then  $f(0) = a_0$  and we have  $f(0) = a_0 \geq 0$  if and only if each term in  $f(x)$  is a multiple of  $x$  and we can factor  $f(x) = xg(x)$ .

Second, if  $a \neq 0$ , then by Remark 3.3.6,  $f(a) \geq 0$  means that there exists a sequence  $t_1, t_2, \dots, t_n$  where  $t_n = a^n$  and

$$0 \leq b_0 + t_1 \text{ and } t_i \leq b_i a^i + t_{i+1}, \text{ for } i = 1, \dots, n - 1. \quad (3.1)$$

In particular, we have the following sequence of inequalities:

$$0 \leq b_0 + t_1 \leq b_0 + b_1 a + t_2 \leq \dots \leq b_0 + b_1 a + \dots + b_{n-1} a^{n-1} + a^n. \quad (3.2)$$

Now, let us define a sequence  $c_0, \dots, c_{n-1}$  by the equations  $-a^i c_i = t_{i+1}$  for  $i =$

$0, \dots, n - 1$ . Then the inequalities in (3.1) say

$$0 \leq b_0 - c_0, \text{ and } -a^{i-1}c_{i-1} \leq b_i a^i - a^i c_i \iff b_i \leq c_i - a c_{i-1}.$$

These are exactly the inequalities which say that  $f(x) \leq (x - a)g(x)$  where  $g(x) = \sum c_i x^i$ .

Conversely, if we know that  $f(x) \leq (x - a)g(x)$ , then we can go backwards and construct a sequence  $t_i$  such that the chain of inequalities in (3.2) hold.  $\square$

### 3.3.2 Multiplicities

Let us return back to idylls and recall the definition of multiplicities.

**Definition 3.0.13.** Let  $B$  be an idyll, let  $f \in B[x]$  be a polynomial and let  $a \in B^\bullet$ . The *multiplicity of  $f$  at  $a$*  is

$$\text{mult}_a^B(f) = 1 + \max \text{mult}_a^B(g),$$

where the maximum is taken over all factorizations of  $f$  into  $(x - a)g$ , or  $\text{mult}_a^B(f) = 0$  if there are no such factorizations.

Examples of factorizations are given in Appendix A.

#### *Morphisms and multiplicities*

The next task is to show that morphisms preserve factorizations and hence multiplicities cannot decrease after applying a morphism. Additionally, we will verify that under isomorphism, multiplicities are the same, and we will apply this to define multiplicities for initial forms.

**Proposition 3.3.8.** Let  $\varphi : B \rightarrow B'$  be a morphism between two idylls. Let  $f = \sum b_i x^i \in B[x]$  be a polynomial, let  $a \in B^\bullet$  and let  $a' = \varphi(a)$ ,  $b'_i = \varphi(b_i)$ . Then

$$\text{mult}_a^B(f) \leq \text{mult}_{a'}^{B'}(\varphi(f)),$$



where  $\varphi(f) = \sum b'_i x^i \in B'[x]$ .

**Lemma 3.3.9.** *A morphism  $\varphi : B \rightarrow B'$  induces a morphism  $\varphi : B[x] \rightarrow B'[x]$  which is multiplicative. I.e. if  $f \preceq gh$  then  $\varphi(f) \preceq \varphi(g)\varphi(h)$ .*

*Proof.* Let us use the notation  $a'$  for  $\varphi(a)$ . It is a simple exercise to verify that  $(ax^n)' := a'x^n$  is a morphism between the two polynomial extensions  $B[x]$  and  $B'[x]$ .

To see that this morphism is multiplicative, first break apart the relation on  $B[x]$  into a collection of relations on  $B$  as follows:

$$\sum a_k x^k \preceq \left( \sum b_i x^i \right) \left( \sum c_j x^j \right) \iff a_k \preceq \sum_{i+j=k} b_i c_j \text{ for all } k.$$

Now apply  $\varphi$  everywhere to obtain

$$a'_k \preceq \sum_{i+j=k} b'_i c'_j \text{ for all } k \implies \sum a'_k x^k \preceq \left( \sum b'_i x^i \right) \left( \sum c'_j x^j \right). \quad \square$$

This result was first stated for hyperfields in [Gun22a, Lemma 3.1]. Proposition 3.3.8 follows by applying this lemma to a sequence of factorizations of  $f$  of maximal length.

Next, we look at how monomial transformations interact with multiplicities.

**Lemma 3.3.10.** *Let  $\varphi : B[x] \rightarrow B[x]$  be a monomial transformation given by  $x \mapsto cx$ . Then for any polynomial  $f \in B[x]$  and  $a \in B$ ,*

$$\text{mult}_a^B(\varphi(f)) = \text{mult}_{ac}^B(f).$$

*Proof.* The proof of this lemma is similar to the proof of Proposition 3.3.8. First, we see that a factorization  $f(x) \preceq (x - ca)g(x)$  yields a factorization

$$f(cx) \preceq (cx - ca)g(cx) = (x - a)[cg(cx)].$$

Then, we apply induction to obtain  $\text{mult}_{ac}^B(f) \leq \text{mult}_c^B(\varphi(f))$ . The opposite inequality

follows by considering the inverse transformation  $x \mapsto c^{-1}x$ .  $\square$

**Definition 3.3.11.** Let  $C \in \text{Ext}^1(\Gamma, B)$ , let  $f \in C[x]$  be a polynomial, and let  $a \in C^\bullet$  be a root of  $f$  with valuation  $\gamma_1$  and corresponding to the line  $\ell = \{\gamma_0 - i\gamma_1 : i \in \mathbf{N}\}$ .

We have  $\text{in}_a f \in B^{\gamma_0}[x]$  and by Lemma 3.3.10, the monomial substitution  $x \mapsto ax$  in the definition of  $\text{in}_a f$  (3.2.23) does not affect the multiplicity. Additionally, for any  $c \in B^{\gamma_0}$ , multiplication by  $c^{-1}$  gives an isomorphism  $B^{\gamma_0} \rightarrow B^0 = B^\times$  which again preserves multiplicity. Therefore, the quantity

$$\text{mult}_{\text{lc}^\bullet(a)}^B(\text{in}_a f) := \text{mult}_1^C(c^{-1} \text{in}_a f)$$

is well-defined. We take this as the general definition of a multiplicity for an initial form.

For split extensions, this multiplicity agrees with the multiplicity of the initial form defined in 3.2.18. This extends Remark 3.2.24.

**Proposition 3.3.12.** *If  $C = B[\Gamma]$  is a split extension, and  $a \in C^\bullet$  has valuation  $\gamma$ , then  $\text{mult}_{\text{lc}^\bullet(a)}^B(\text{in}_a f)$  as defined in 3.3.11 is equal to  $\text{mult}_{\text{lc}^\bullet(a)}^B(\text{in}_\gamma f)$  as defined in 3.0.13.*

*Proof.* From Remark 3.2.24, if  $a = b^\gamma$ , then

$$\text{in}_a f(x) = \text{in}_{1^\gamma} f(bx) = 1^{\gamma_0} \text{in}_\gamma f(bx).$$

Next, from Definition 3.3.11, we defined

$$\text{mult}_{\text{lc}^\bullet(a)}^B(\text{in}_a f) = \text{mult}_1^{B[\Gamma]}(1^{-\gamma} \text{in}_{1^\gamma} f(bx)) = \text{mult}_1^{B[\Gamma]}(\text{in}_\gamma f(bx)).$$

We want to check that computing this multiplicity in  $B[\Gamma][x]$  rather than in  $B[x]$  makes no difference.

First, since  $B$  embeds in  $B[\Gamma]$ , we have an inequality

$$\text{mult}_1^B(\text{in}_\gamma f(bx)) \leq \text{mult}_1^{B[\Gamma]}(\text{in}_\gamma f(bx))$$

by Proposition 3.3.8.

Second, suppose we have some factorization  $\text{in}_\gamma f(bx) \leq (x-1)g(x)$  in  $B[\Gamma][x]$ . And now remember that by definition of  $N_{B[\Gamma]}$  (3.2.4), a relation holds if and only if it holds among just the terms of smallest valuation. I.e. if we let  $\tilde{g}(x)$  be obtained from  $g(x)$  by throwing out any higher order terms, then we have the relation  $\text{in}_\gamma f(bx) \preceq (x-1)\tilde{g}(x)$  in  $B[x]$ . Therefore, by induction, we have

$$\text{mult}_1^B(\text{in}_\gamma f(bx)) = \text{mult}_1^{B[\Gamma]}(\text{in}_\gamma f(bx)).$$

We finish by observing that

$$\text{mult}_1^B(\text{in}_\gamma f(bx)) = \text{mult}_b^B(\text{in}_\gamma f(x)) = \text{mult}_{1c \bullet (a)}^B(\text{in}_\gamma f). \quad \square$$

### 3.4 Hyperfields

We defined hyperfields as idylls in Definition 3.1.14. Or, more specifically, we defined idylls of *quotient* hyperfields. In this section, we make use of the language of pastures from the previous section to describe hyperfields in more detail. Then we will explain how our definition of tropical extension generalizes the semidirect product of Bowler and Su [BS21].

**Definition 3.4.1.** A hyperfield is a pasture  $H$ , such that the *hypersum*  $a \boxplus b := \{c : c \leq a+b\}$  is always nonempty and the operation  $\boxplus$  is associative:

$$(a \boxplus b) \boxplus c = \bigcup_{t \in a \boxplus b} t \boxplus c = \bigcup_{t \in b \boxplus c} a \boxplus t = a \boxplus (b \boxplus c).$$

Here we are using the monadic laws discussed in (Remark 3.1.16).

**Example 3.4.2.** The tropical hyperfield is the hyperfield on  $\mathbf{R} \cup \{\infty\}$  where  $a \in b \boxplus c$  if the minimum of  $a, b, c$  occurs at least twice. The tropical idyll is the idyllic part of this pasture. ◇

**Example 3.4.3.** The sign hyperfield is the hyperfield on  $\mathbf{S}^\bullet = \{0, 1, -1\}$  and where addition is defined by

$\boxplus$	0	1	-1
0	0	1	-1
1	1	1	$\mathbf{S}^\bullet$
-1	-1	$\mathbf{S}^\bullet$	-1

The sign idyll is the idyllic part of this pasture. ◇

**Definition 3.4.4.** A hypergroup  $H$  is a set  $H$  together with a distinguished element  $0$  and hypersum operation  $\boxplus$  from  $H \times H$  to the powerset of  $H$  such that for all  $x, y, z \in H$ :

- $\boxplus$  is commutative and associative,
- $0 \boxplus x = \{x\}$ ,
- there exists a unique element  $-x$  such that  $0 \in x \boxplus (-x)$ ,
- $x \in y \boxplus z$  if and only if  $-y \in (-x) \boxplus z$ .

**Remark 3.4.5.** *Another definition (the standard one) of a hyperfield is that it is a hypergroup with a multiplication which distributes over hypersums and which has multiplicative inverses. I.e. hyperfields are monoids in the category of hypergroups.*

We now describe Bowler and Su's semidirect product construction in a slightly-modified language. Because we work in a commutative setting, we can simplify some conditions required by non-commutativity.

**Definition 3.4.6.** Let  $B$  be a hyperfield, let  $H = (H, 1, \cdot)$  be an Abelian group written multiplicatively, and let  $\Gamma$  be an OAG. Suppose we have an exact sequence

$$1 \rightarrow B^\times \xrightarrow{\iota} H \xrightarrow{v} \Gamma \rightarrow 1, \tag{3.3}$$

and we will assume that  $\iota$  is the identity.

Define  $H^\bullet = H \cup \{0\}$  to be the monoid obtained by formally adding an absorbing element 0 to  $H$ . Next, for each  $\gamma \in \Gamma$ , let  $B^\gamma = v^{-1}(\gamma)$  as in Definition 3.2.22.

If  $x, y \in B^\gamma \cup \{0\}$  and  $c \in B^\gamma$ , we can define  $x \boxplus_\gamma y = \{z \in B^\gamma \cup \{0\} : (c^{-1}z) \in (c^{-1}x) \boxplus (c^{-1}y) \text{ in } B\}$ . This hypersum is independent of  $c$ , because if  $c_1, c_2 \in B^\gamma$  then multiplication by  $c_1 c_2^{-1}$  is an automorphism of  $B$ . This defines a hypersum on  $B_\gamma := B^\gamma \cup \{0\}$  and makes  $B_\gamma$  into a hypergroup.

The  $\Gamma$ -layering  $B \rtimes_{H,v} \Gamma$  of  $B$  along this short exact sequence is a hyperfield whose underlying monoid is  $H^\bullet$  and where  $y \boxplus z$  is

- (H1)  $\{y\}$  if  $v(y) < v(z)$ ,
- (H2)  $\{z\}$  if  $v(z) < v(y)$ ,
- (H3)  $y \boxplus_\gamma z$  if  $v(y) = v(z) =: \gamma$  and  $0 \notin y \boxplus_\gamma z$ ,
- (H4)  $y \boxplus_\gamma z \cup \{x : v(x) > \gamma\}$  if  $0 \in y \boxplus_\gamma z$ .

**Proposition 3.4.7.** *The Bowler-Su semidirect product  $C := B \rtimes_{H,v} \Gamma$  is a tropical extension in the sense of Definition 3.0.7.*

*Proof.* Since the underlying monoid of  $C$  is  $H^\bullet$ , the short exact sequence in equation (3.3) is the same as

$$1 \rightarrow B^\times \xrightarrow{\iota} C^\times \xrightarrow{v} \Gamma \rightarrow 1$$

in Definition 3.0.7.

Next, let us check that  $\text{im}(\iota) = \text{eq}(v, 1)$ , i.e. that  $B$  is a full subblueprint of  $C$ . By construction, we have  $B^\bullet = \text{eq}(v, 1)^\bullet$  as monoids. We need to check relations. If  $x, y, z \in B^\bullet$ , then we can take  $c = 1_C$  in the definition of  $\boxplus_0$  to see that  $x \in y \boxplus z$  in  $B$  if and only if  $x \in y \boxplus_0 z$  in  $C$  if and only if  $x \in y \boxplus z$  in  $C$  (compare (H3)). Therefore  $\text{im}(\iota)$  is a full subblueprint and hence equal to  $\text{eq}(v, 1)$ .

Finally, we need to check that  $x \in y \boxplus z$  if and only if this holds when looking at just the terms of minimal valuation.

- If  $v(x) = v(y) < v(z)$  then  $x \in y \boxplus z$  if and only if  $x \in y \boxplus 0$  by (H1).
- If  $v(x) = v(z) < v(y)$  then  $x \in y \boxplus z$  if and only if  $x \in 0 \boxplus z$  by (H2).
- If  $v(y) = v(z) < v(x)$  then  $x \in y \boxplus z$  if and only if  $0 \in y \boxplus z$  by (H4).
- If the minimum valuation does not occur at least twice, then vacuously there are no  $x, y, z$  such that  $x \in y \boxplus z$  and neither do we have any the relations  $0 \in y \boxplus 0, 0 \in 0 \boxplus z$  or  $x \in 0 \boxplus 0$ .

So we conclude that  $C$  is a tropical extension. □

### 3.5 Lifting Theorem for Multiplicities

We have defined tropical extensions, initial forms and multiplicities and seen that our definitions agree with each other. Now we are ready to prove the main theorem, and we will do this over the course of this section. First, let us recall the definition of *wholeness* from the introduction.

**Definition 3.5.1.** An idyll  $B$  is *whole* if for every pair of elements  $a, b \in B^\bullet$ , there exists at least one element  $c$  such that  $c \preceq a + b$ .

Recall that in language of hyperfields or partial fields, we have a notion of sum sets:  $a \boxplus b = \{c : c \preceq a + b\}$  (Remark 3.1.15). A pasture is whole if every sum is non-empty. So hyperfields and fields are always whole, but partial fields are only whole if they are fields. Whole idylls are closely related therefore to hyperfields.

**Remark 3.5.2.** *If  $B$  is whole, then any tropical extension by  $B$  is also whole. We have two cases. First, if  $v^\bullet(a) = v^\bullet(b)$ , then both  $a$  and  $b$  live in some torsor  $B^\gamma$ . Now take  $c \in B^\gamma$  and consider  $c^{-1}a, c^{-1}b \in B^0 = B^\times$ . Since  $B$  is whole, we can find an element  $c'$  such that  $c' \preceq c^{-1}a + c^{-1}b$  and then multiply both sides by  $c$  to get  $cc' \preceq a + b$ .*

*Otherwise, if  $v^\bullet(a) < v^\bullet(b)$ , say, then  $a \preceq a + b$  because this relation is true among the minimum valuation terms.*

This brings us to the main theorem. Let us recall.

**Theorem 3.B.** *Let  $B$  be a whole idyll and let  $C \in \text{Ext}^1(\Gamma, B)$  be a tropical extension of  $\Gamma$  by  $B$ . Let  $f \in C[x]$  be a polynomial and let  $a \in C^\bullet$  be a root of  $f$ . Then*

$$\text{mult}_a^C(f) = \text{mult}_{\text{lc}^\bullet(a)}^B(\text{in}_a(f)).$$

Theorem 3.A, which describes the split case, is a direct corollary of this theorem in light of Proposition 3.3.12.

**Lemma 3.5.3.** *Let  $C \in \text{Ext}^1(\Gamma, B)$  and define the idyllic subblueprint  $\mathcal{O}_C$  of  $C$  to be the induced subblueprint corresponding to the submonoid  $\{c \in C^\bullet : v^\bullet(c) \geq 0\}$ . Let  $\text{ev}_0 : \mathcal{O}_C \rightarrow B$  be the map which “evaluates  $t$  at 0” meaning*

$$\text{ev}_0^\bullet(c) = \begin{cases} c & \text{if } c \in B^0, \\ 0 & \text{if } c \in B^\gamma, \gamma > 0. \end{cases}$$

*Then  $\text{ev}_0$  is a morphism.*

The language of “evaluating  $t$  at 0” comes from the split case, wherein  $\text{ev}_0^\bullet(bt^\gamma) = bt^\gamma$  with the usual convention that  $0^0 = 1$ .

*Proof.* Simple case checking shows that  $\text{ev}_0 : \mathcal{O}_C \rightarrow B^\bullet$  is a morphism. It is left then to check that  $\text{ev}_0(N_{\mathcal{O}_C}) \subseteq N_B$ .

Given  $\sum c_i \in N_{\mathcal{O}_C}$ , there are two cases. First, if every  $c_i$  has a positive valuation, then  $\text{ev}_0(\sum c_i) = 0_B \in N_B$ . Second, suppose that  $I = \{i : v^\bullet(c_i) = 0\}$  is non-empty. Then by definition of  $N_C$ , we must have  $\sum_I c_i \in N_{\mathcal{O}_C} \subset N_C$  since 0 is the minimum valuation. But  $\sum_I c_i$  also lives in  $B^0 = B^\times$ , so we get  $\sum_I c_i = \text{ev}_0(\sum c_i) \in N_B$ .  $\square$

**Lemma 3.5.4.**  $\text{mult}_a^C(f) \leq \text{mult}_{\text{lc}^\bullet(a)}^B(\text{in}_a(f))$ .

*Proof.* Recall that the initial form of a polynomial  $f = \sum c_i x^i \in C[x]$  is defined as

$$\text{in}_a(f) = \sum_I \text{lc}^\bullet(c_i)(ax)^i \in B^{\gamma_0}[x],$$

where  $I = \{i : v^\bullet(c_i a^i) \text{ is minimal}\}$  and  $\gamma_0$  is that minimum value. In other words, this initial form is obtained from the polynomial  $g(x) = f(ax)$  by restricting the sum to  $I$ . Observe that by Lemma 3.3.10, we have  $\text{mult}_1^C g = \text{mult}_a^C f$ .

Next, choose any  $c \in B^{\gamma_0}$ . By Proposition 3.3.8, and the fact that multiplication by  $c$  is invertible, we have  $\text{mult}_1^C c^{-1}g = \text{mult}_1^C g$ , independent of the choice of  $c$ .

Now observe that  $c^{-1}g \in \mathcal{O}_C[x]$  and  $\text{ev}_0(c^{-1}g) = c^{-1} \text{in}_a(f)$ . So because  $\text{ev}_0$  is a morphism (Lemma 3.5.3), we must have

$$\text{mult}_1^C c^{-1}g \leq \text{mult}_1^B c^{-1} \text{in}_a(f).$$

By what we have said, the left side of this inequality is  $\text{mult}_a^C(f)$  and the right side is  $\text{mult}_{\text{lc}^\bullet(a)}^B(\text{in}_a(f))$ . □

**Lemma 3.5.5.** *In proving Theorem 3.B, we may assume that  $\Gamma = \mathbf{R}$ .*

*Proof.* We would like to appeal to Lemma 3.2.20 and induction, but in order to do so, we need a finite-rank hypothesis. We can get this by considering the subgroup generated by the coefficients.

Specifically, let  $f \preccurlyeq (x - a)g_0$  and  $g_k \preccurlyeq (x - a)g_{k+1}$  be a sequence of factorizations of maximal length. Let  $\Gamma'$  be the subgroup generated by the coefficients of  $f, g_0, g_1, \dots$ . If we define  $C' = \bigcup_{\gamma \in \Gamma'} B^\gamma$ , then  $\text{mult}_a^C f = \text{mult}_a^{C'} f$  and  $\text{rank } \Gamma' < \infty$ . □

We now have everything in hand to prove the lifting theorem.

**Theorem 3.C.** *Any factorization of  $\text{in}_a f$  into  $(x - 1)g$  can be lifted to a factorization of  $f$  into  $(x - a)\tilde{g}$  such that  $\text{in}_a \tilde{g} = g$ .*



*Proof.* First, by making monomial substitutions  $x \mapsto ax$  or  $x \mapsto a^{-1}x$  in the appropriate places, we are going to assume that  $a = 1$ . Also, by multiplying by  $c$  or  $c^{-1}$  for some  $c \in B^{\gamma_0}$ , we are going to assume that the minimal valuation of the terms in  $f$  or  $\text{in}_1 f$  is exactly 0. As a consequence, we now have the identity  $\text{in}_1 f = \text{ev}_0 f \in B[x]$ , and by the last half of the proof of Proposition 3.3.12 regarding factorization in  $B$  versus in  $B[\Gamma]$ , there is no loss of generality treating this as a polynomial over  $B$  rather than over  $C$ .

From Lemma 3.5.5, we can assume that  $\Gamma = \mathbf{R}$ , and this will allow us to consider the Newton polygon as defined in subsection 3.2.1. We will break up the polynomial's support into three intervals. Let  $i_0 = \min\{i : v^\bullet(c_i) = 0\}$  and  $i_1 = \max\{i : v^\bullet(c_i) = 0\}$ . Let  $I_L = \{i : i < i_0\}$  be the *left* interval, let  $I_M = \{i : i_0 \leq i \leq i_1\}$  be the *middle* interval, let  $I_R = \{i : i > i_1\}$  be the *right* interval, and as always, we define  $I = \{i : v^\bullet(c_i) = 0\}$ . See Figure 3.4 for a visual.

So suppose we have  $\text{in}_1 f \preccurlyeq (x - 1)g$ , where  $f = \sum c_i x^i$  and  $g = \sum d_i x^i$ . In what follows, we will treat the coefficients as infinite sequences by defining the terms not appearing in the sum to be 0. Then, we will modify the coefficients of  $g$  by redefining them in such a way that if  $\tilde{g}$  is obtained from  $g$  by redefining some  $d_i$ 's then  $\text{in}_1 \tilde{g} = \text{ev}_0 \tilde{g} = g$ . In particular, if  $d_i$  is non-zero then we do not touch it and if  $d_i = 0$  then it might be redefined to another element of positive valuation.

**Claim 1.** *The support of  $g$  is contained in  $i_0, \dots, i_1 - 1$  and  $d_{i_0} \neq 0$  and  $d_{i_1-1} \neq 0$ .*

These facts are the same as for polynomials over a field. For instance, we know that  $\deg g = \deg(\text{in}_1 f) - 1$  because there are no zero-divisors in an idyll. For the smallest non-zero coefficient, we can write  $f = x^{d_0} f_0$  and  $g = x^k g_0$  where  $k$  is maximal. If  $k \neq d_0$  then we can divide both sides of  $\text{in}_1 f \preccurlyeq (x - 1)g$  by  $x^{\min\{k, d_0\}}$  and set  $x = 0$  (i.e. consider the relation in degree 0) to get a contradiction.  $\diamond$

Next, let us describe how to lift  $g$  on each of the left, middle and right parts of the Newton polygon. We will start with the middle since  $\text{in}_1 f$  is supported there.

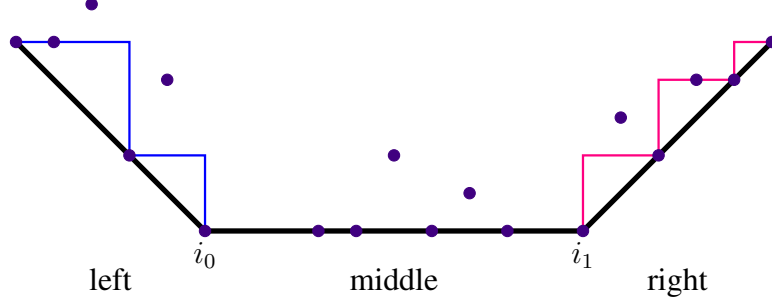

Figure 3.4: Newton polygon describing the construction

**Claim 2.** We have  $\sum_{I_M} c_i x^i \preccurlyeq (x-1)g$  (with no changes to  $g$ ).

To say that  $\text{in}_1 f \preccurlyeq (x-1)g$  means that  $c_i \preccurlyeq d_{i-1} - d_i$  for  $i \in I$ . But it also means that  $0 \leq d_{i-1} - d_i$  for  $i \in I_M \setminus I$ . Now, if  $c \in C^\bullet$  has a positive valuation, then we also have  $c \preccurlyeq d_{i-1} - d_i$ , since by definition of  $N_C$ , a relation holds in  $C$  if and only if it holds among just the terms of minimal valuation. Therefore  $c_i \preccurlyeq d_{i-1} - d_i$  for all  $i \in I_M$ .  $\diamond$

Next we look at  $I_L$ . Here, we will begin by redefining  $d_0 = -c_0$ . After that, there are three kinds of points in the Newton polygon/indices  $i$ . First, there are the points where  $v^\bullet(c_i) < \min\{v^\bullet(c_k) : k < i\}$  (in the diagram these are where the blue staircase on the left descends). Second, there are points where  $v^\bullet(c_i) = \min\{v^\bullet(c_k) : k < i\}$  (points along the flats of the staircase). Then finally, there are points where  $v^\bullet(c_i) > \min\{v^\bullet(c_k) : k < i\}$  (points above the staircase).

For the points where the staircase descends, we define  $d_i = -c_i$ . For the points on or above the flats of the staircase, inductively define  $d_i$  to be any element for which  $d_i \preccurlyeq d_{i-1} - c_i$  (making use of the wholeness axiom). Note that because  $v$  is a valuation,  $v^\bullet(d_i) \geq \min\{v^\bullet(d_{i-1}), v^\bullet(c_i)\}$  and so these have a positive valuation if  $i < i_0$ . We make these redefinitions for all  $i \in I_L$ .

**Claim 3.** We have  $\text{in}_1 \tilde{g} = g$  and  $\sum_{I_L \cup I_M} c_i x^i \preccurlyeq (x-1)\tilde{g}$ .

For the first part of the claim, we note that based on how we have redefined  $d_i$ , any time we changed a value, it was a zero value becoming a value with a positive valuation.

We need to check that  $c_i \preceq d_{i-1} - d_i$  for  $i = 1, \dots, i_0 - 1$ . We have already verified this for  $i = i_0, \dots, i_1$  with the exception that now for  $i_0$ , we have  $d_{i_0-1} \neq 0$ , this change is handled below in Case 1.

To start, the relation  $c_0 \preceq 0 - d_0$  holds by definition. From there, we proceed by induction.

Case 1: if we are at a point where the staircase descends, then we have  $v^\bullet(c_i) = v^\bullet(d_i) < v^\bullet(d_{i-1})$ . Here the relation  $c_i \preceq d_{i-1} - d_i$  holds because it holds among the minimal valuation terms:  $c_i \preceq -d_i$ .

Case 2: if we are on or above one of the flats, then the definition  $d_i \preceq d_{i-1} - c_i$  is equivalent to  $c_i \preceq d_{i-1} - d_i$ .  $\diamond$

Lastly, we need to define  $d_i$  for  $i \in I_R$  and also  $d_{i_1}$ . We will start by defining another staircase function:  $j(i) = \min\{k : v^\bullet(c_k) \text{ is minimal and } k > i\}$ . In the diagram,  $j(i)$  is the next  $x$ -coordinate along the **pink staircase** on the right. When  $j(i-1) \neq j(i)$ , we will define  $d_{i-1} = c_i$ . Otherwise, we let  $d_i$  be any element satisfying  $d_i \preceq d_{i-1} + c_{i+1}$ .

**Claim 4.** We have  $\text{in}_1 \tilde{g} = g$  and  $\sum c_i x^i \preceq (x-1)\tilde{g}$ .

As with the last claim, the first part just comes down to verifying that any time we have redefined a zero-valued  $d_i$ , the new value has a positive valuation. This is true here because  $v^\bullet(c_i) > 0$  for any  $i > i_1$  by definition of  $i_1$ .

Now we need to check that  $c_i \preceq d_{i-1} - d_i$  for  $i = i_1 - 1, i_1, i_1 + 1, \dots$ . The indices in  $I_L \cup I_M$  have already been checked except for  $i_1$ , since we have given a new value to  $d_{i_1}$ . Again we have two cases:

Case 1: if  $j(i-1) \neq j(i)$  then that is because  $v^\bullet(c_i) < v^\bullet(c_k)$  for any  $k > i$ . Here we have  $d_{i-1} = c_i$  and  $v^\bullet(d_i) > v^\bullet(d_{i-1})$ . Thus  $c_i \preceq d_{i-1} - d_i$  because the minimal valuation part of this relation is  $c_i \preceq d_{i-1}$ .

Case 2: if  $j(i-1) = j(i)$  then we proceed by induction. The sequence  $j(i)$  is non-decreasing and as a base case, we know that  $c_i \preceq d_{i-1} - d_i$  every time  $j(i-1) < j(i)$ .

Given  $c_i \preceq d_{i-1} - d_i$  and  $j(i-1) = j(i)$ , we will check that  $c_{i+1} \preceq d_i - d_{i+1}$ . Indeed, this is exactly how we defined  $d_{i+1}$ , so that this relation would hold.  $\square$

Finally, we finish the proof of Theorem 3.B. We do what we have done before: take a factorization sequence of  $\text{in}_1 f$  of maximal length and lift it to a factorization sequence of  $f$ . That gives us

$$\text{mult}_a^C(f) \geq \text{mult}_{\text{lc}^\bullet(a)}^B(\text{in}_a f).$$

Combining this with Lemma 3.5.4, we obtain Theorem 3.B.

### 3.6 Examples and Connections

Theorems 3.A and 3.B imply some results of previous papers. First of all, it gives a new proof of Theorem D from Baker and Lorscheid's paper [BL21a].

**Corollary 3.6.1.** *Let  $f \in \mathbf{T}[x]$  and for  $a \in \mathbf{R}$ , define  $v_a(f)$  to be  $j - i$  if the edge in the Newton polygon of  $f$  with slope  $-a$  has endpoints  $(i, c_i)$  and  $(j, c_j)$ . If there is no such edge, define  $v_a(f) = 0$ .*

*Given this, we have  $\text{mult}_a^{\mathbf{T}}(f) = v_a(f)$ .*

*Proof.* By Theorem 3.A, we have  $\text{mult}_a^{\mathbf{T}}(f) = \text{mult}_1^{\mathbf{K}}(\text{in}_a f)$  and  $\text{in}_a f$  is the sum of  $x^k$  over all  $k$  such that  $(k, c_k)$  is in the edge of slope  $-a$ . And for the Krasner idyll, we have  $\text{mult}_1^{\mathbf{K}}(x^i + \cdots + x^j) = j - i$  (Example A.0.1).  $\square$

Next, let us have a look at the extension  $\mathbf{TR} = \mathbf{S}[\mathbf{R}] \in \text{Ext}^1(\mathbf{R}, \mathbf{S})$  which was the main focus of [Gun22a].

**Corollary 3.6.2.** *Let  $f \in \mathbf{TR}[x]$  and  $a = (+1)^\gamma \in \mathbf{TR}^\bullet$ . Then  $\text{mult}_a^{\mathbf{TR}} f$  equals the number of sign changes among the coefficients corresponding to points in  $\text{Newt } f$  inside the edge of slope  $-\gamma$ .*

*Proof.* By Theorem 3.A, we have  $\text{mult}_a^{\mathbf{R}} f = \text{mult}_{+1}^{\mathbf{S}} \text{in}_\gamma f$ , where with the notation we have been using,  $\text{in}_\gamma f = \sum_I \text{lc}^\bullet(c_i)x^i$  and  $I$  is the set of all  $i$  such that  $(i, v^\bullet(c_i))$  is contained in the edge of  $\text{Newt } f$  with slope  $-\gamma$ .

Next, by [BL21a, Theorem C],  $\text{mult}_{+1}^{\mathbf{S}} \text{in}_\gamma f$  is equal to the number of sign changes in the sequence  $(\text{lc}^\bullet(c_i) : i \in I)$ —ignoring zeroes.  $\square$

**Remark 3.6.3.** *The next place to look would be at multiplicities over  $\mathbf{TC}$ . We still have that  $\text{mult}_a^{\mathbf{TC}} f = \text{mult}_{\text{lc}^\bullet(a)}^{\mathbf{P}} \text{in}_{v^\bullet(a)} f$  but there is no existing simple description of  $\text{mult}^{\mathbf{P}}$ . In fact, polynomials over  $\mathbf{P}$  have some pathologies as pointed out by Philipp Jell [BL21a, Remark 1.10]: the polynomial  $x^2 + x + 1 \in \mathbf{P}[x]$  has a root at  $e^{i\theta}$  for all  $\pi/2 < \theta < 3\pi/2$ . In contrast, polynomials over  $\mathbf{K}$  or  $\mathbf{S}$  or tropical extensions thereby, can only have finitely many roots.*

### 3.6.1 Higher rank

Combining Lemma 3.2.20 with the main theorem, tells us how to compute multiplicities of polynomials in the context of a higher-rank valuation.

**Example 3.6.4.** Consider the following polynomial over  $\mathbf{C}(s, t)$  with valuation  $v^\bullet(s^m t^n) = (m, n) \in (\mathbf{R}^2, \leq_{\text{lex}})$ :

$$\begin{aligned} f &= (x - t)(x - s)(x - st)(x - 2st) \\ &= x^4 \\ &\quad - (t + s + 3st)x^3 \\ &\quad + (st + 3st^2 + 3s^2t + 2s^2t^2)x^2 \\ &\quad - (3s^2t^2 + 2s^2t^3 + 2s^3t^2)x \\ &\quad + 2s^3t^3. \end{aligned}$$

Suppose we want to know how many roots of  $f$  have valuation  $(1, 1)$ . I.e. what is

$\text{mult}_{(1,1)}^{\mathbf{T}_2} \text{trop}(f)$  where

$$\text{trop}(f) = (3, 3) + (2, 2)x + (1, 1)x^2 + (0, 1)x^3 + x^4 \in \mathbf{T}_2[x]$$

By Lemma 3.2.20, we start by considering the  $s$ -valuation  $v_s(s^m t^n) = m$  and draw a

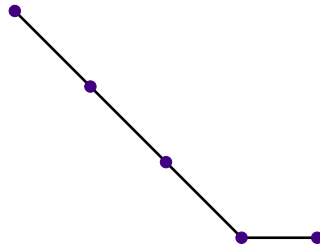

Figure 3.5: Newton polygon of  $f$  with respect to  $v_s$  in Example 3.6.4

Newton polygon based on the first coordinate of each coefficient (Figure 3.5). Then, we pick out the line segment of slope  $-1$  to create the initial form

$$\text{in}_1 \text{trop}(f) = 3 + 2x + 1x^2 + 1x^3 \in \mathbf{T}[x].$$

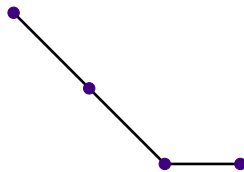

Figure 3.6: Newton polygon of  $\text{in}_1 \text{trop}(f)$  in Example 3.6.4

Next, we draw the Newton polygon of this initial form with respect to the  $t$ -valuation (Figure 3.6). Here we can take another initial form to get  $\text{in}_1(\text{in}_1 \text{trop}(f)) = 1 + x + x^2 \in \mathbf{K}[x]$ . So  $\text{mult}_{(1,1)}^{\mathbf{T}_2} \text{trop}(f) = 2$ .  $\diamond$

### 3.6.2 Connection to polynomials over fields

Let us summarize what is known about a question which has been discussed before in [BL21a] and [Gun22a]: given a morphism  $\varphi$  from a field  $K$  to an idyll  $B$ , and a polynomial  $F \in K[x]$  lying over  $f \in B[x]$ , what can we say about multiplicities in  $K$  compared to in  $B$ ?

There are two questions here: local and global. Locally, we have the following inequality [BL21a, Proposition B]:

$$\text{mult}_b^B f \geq \sum_{a \in \varphi^{-1}(b)} \text{mult}_a^K F. \quad (3.4)$$

Globally, we know that the sum of the multiplicities in  $B$  might be infinite (Remark 3.6.3).

Here we will give a partial answer to the question that Baker and Lorscheid asked about when a hyperfield satisfies the degree bound, which in Definition 3.0.16 we defined as:

$$\sum_{b \in B} \text{mult}_b^B f \leq \deg f$$

for all polynomials  $f \in B[x]$ . By their Proposition B, a corollary of this bound is that (3.4) becomes an equality.

**Theorem 3.D.** *If  $B$  satisfies the degree bound and  $C \in \text{Ext}^1(\Gamma, B)$ , then  $C$  satisfies the degree bound.*

*Proof.* Let  $f \in C[x]$  be a polynomial. Since any one polynomial only requires a finite-rank value group to define, we are going to again assume that  $\Gamma = \mathbf{R}$ , use induction to extend to any finite-rank value group, and then use the fact that any polynomial lives in a finite-rank sub-extension.

With this reduction, consider the polynomial  $v(f) \in \mathbf{T}[x]$  via the morphism  $v : C \rightarrow \mathbf{T}$ . The Newton polygon will have a finite number of edges and hence a finite number of non-monomial initial forms, say  $\text{in}_{\gamma_k} v(f)$  for  $k = 1, \dots, d$ . Now, let  $a_k \in B^{\gamma_k} \subseteq C$  be a representative of  $\gamma_k$ . Each initial form is not-necessarily-canonically isomorphic to a polynomial in  $B[x]$ , and we are going to use the degree bound in  $B$  to get a bound in  $C$ .

First of all, we partition the roots of  $f$  by valuation so

$$\sum_{a \in C} \text{mult}_a^C f = \text{mult}_0^C f + \sum_{k=1}^d \sum_{a \in B^{\gamma_k}} \text{mult}_a^C f.$$

Next, we will show that

$$\sum_{a \in B^{\gamma_k}} \text{mult}_a^C f \leq \deg \text{in}_{a_k} f - \text{mult}_0^C \text{in}_{a_k} f. \quad (3.5)$$

This will suffice to prove the theorem, because

$$\sum_{k=1}^d (\deg \text{in}_{a_k} f - \text{mult}_0^C \text{in}_{a_k} f) = \deg f + \text{mult}_0^C f.$$

This holds because the width of the Newton polygon is equal to the sum of the widths of each edge in the polygon.

To show (3.5), apply some transformation  $c_k^{-1} f(a_k x)$  to get a polynomial in  $\mathcal{O}_C[x]$ . Then apply  $\text{ev}_0$  to get a polynomial in  $B[x]$ . By Theorem 3.B and Theorem 3.C, there is an equality between multiplicities of valuation 0 roots of  $c_k^{-1} f(a_k x)$  and non-zero roots of  $\text{ev}_0(c_k^{-1} f(a_k x)) \in B[x]$ . This shows (3.5).  $\square$

Since we know that the Krasner and sign hyperfields satisfy the degree bound, we have the following corollary.

**Corollary 3.6.5.** *If  $B$  is either a field or  $\mathbf{K}$  or  $\mathbf{S}$ , and  $C \in \text{Ext}^1(\Gamma, B)$  then  $C$  satisfies the degree bound. For example, this applies to  $C = \mathbf{K}, \mathbf{S}, \mathbf{T}, \mathbf{TR}$  and the higher-rank versions  $\mathbf{T}_n = \mathbf{K}[\mathbf{R}^n]$  and  $\mathbf{S}[\mathbf{R}^n]$ .*

*Proof.* Combine Theorem 3.D with [BL21a, Proposition B].  $\square$

Based on a classification of Bowler and Su, we can conclude that so-called *stringent* hyperfields satisfy the degree bound.

**Definition 3.6.6.** A hyperfield (idyll) is *stringent* if the sum-set  $a \boxplus b = \{c : c \preceq a + b\}$  is a singleton whenever  $a \neq b$ .

**Corollary 3.E.** *Every stringent hyperfield satisfies the degree bound.*



*Proof.* Combine Corollary 3.6.5 with Bowler and Su’s classification of stringent hyperfields [BS21, Theorem 4.10]. □

*Some open questions*

Corollary 3.E leads to several interesting questions.

**Question.** *Is there a more direct proof of Corollary 3.E which does not rely on Bowler and Su’s classification?*

**Question.** *Is the converse of Corollary 3.E true? I.e. if a hyperfield satisfies the degree bound, is it necessarily stringent?*

**Question.** *Baker and Zhang show that a hyperfield is stringent if and only if its associated idyll satisfies a “strong-fusion axiom” [BZ23, Proposition 2.4]. If the previous question has a positive answer, can we extend that to pastures or idylls with an additional axiom like strong-fusion?*

## CHAPTER 4

### FACTORIZING MULTIVARIATE POLYNOMIALS OVER HYPERFIELDS AND THE MULTIVARIABLE DESCARTES' PROBLEM

*Joint work with Andreas Gross.*

Famously, Descartes' Rule of Signs states that the number of positive solutions of a polynomial

$$f(x) = a_0 + a_1x + \cdots + a_nx^n \in \mathbf{R}[x]$$

is bounded above by the number of sign changes of the sequence of coefficients  $a_0, \dots, a_n$ . Numerous proofs have been found since Descartes' original work [Kri63; Alb43], some of which are extremely short [Wan04; Kom06]. There are several generalizations of Descartes' Rule of Signs as well: the Budan–Fourier theorem and Sturm's theorem give estimates of the number of solutions of real polynomials in a given interval in terms of the number of sign changes of suitable sequences of real numbers. Laguerre proved, using Rolle's theorem, that Descartes' rule also holds if the exponents appearing in  $f$  are arbitrary real numbers, and the problem of finding and characterizing more general functions satisfying Descartes' rule has received some attention [HT11; Tok11; Cur18]. Descartes' bound (in the polynomial setting) is also known to be sharp [Gra99].

In multiple variables, one possible generalization of Descartes' rule considers a single polynomial  $f(\mathbf{x})$  in several variables and asks on how many components of the complement of its vanishing set the polynomial  $f(\mathbf{x})$  can be positive, given the signs of its coefficients [FT22]. Another generalization considers systems of real polynomial equations  $0 = f_1(\mathbf{x}) = f_2(\mathbf{x}) = \cdots$  and asks how many solutions with only positive entries such a system can have, given the signs of the coefficients of each of the  $f_i$ . This latter formulation was first studied by Itenberg and Roy [IR96], who made a conjecture for a sharp upper bound of positive

solutions in terms of Newton polytopes and mixed subdivisions. Popularized by a \$500 bounty by Bernd Sturmfels, the conjecture received some attention and was later disproven [LW98]. More recently, Bihan-Dickenstein and Bihan-Dickenstein-Forsgård gave a sharp upper bound for the number of positive solutions of systems of polynomials supported on a circuit [BD17; BDF21]. The general case is still wide open.

**Example 4.0.1.** With multiple variables, it is possible to have a family of equations with consistent signs but whose solutions have varying signs. This phenomenon does not happen in one variable where, if the coefficients change  $k$  times, Descartes' rule tells us that there will always be exactly  $k$  positive roots assuming all the roots are real. For example, consider the system

$$\begin{aligned}x^2 + y^2 &= 1, \\ax + by &= 1, \\a, b &> 0.\end{aligned}$$

The space of real solution sets consists of four open components as shown in Figure 4.1.  $\diamond$

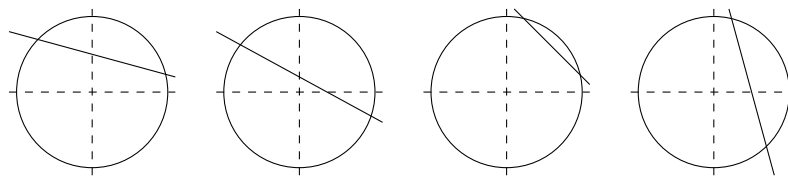

Figure 4.1: Possible sign patterns which arise from intersecting a line with the unit circle.

#### 4.0.1 Descartes' rule and hyperfields

Hyperfields are generalizations of fields, where addition may be multivalued. These appear naturally when looking at the quotient of a field by a multiplicative group. For instance, we can take the real numbers and quotient by the group of absolute values ( $\mathbf{R}_{>0}$ ) to obtain the hyperfield of signs  $\mathbf{S} = \{+1, -1, 0\}$ . The arithmetic of signs has rules such as  $1 + 1 = 1$

(the sum of two positive numbers is always positive) and  $1 + (-1) = \mathbf{S}$  (the sum of a positive and negative number may have any sign). Similarly, if we quotient  $\mathbf{R}$  by  $\{\pm 1\}$ , we get a hyperfield which encapsulates the arithmetic of absolute values. Arithmetic of non-Archimedean absolute values is often used in tropical geometry. We call this hyperfield the *tropical hyperfield*,  $\mathbf{T}$ . This hyperfield is an enrichment of the tropical semifield. We can also combine signs and non-Archimedean absolute values with the so-called real tropical hyperfield  $\mathbf{TR}$ , which is a sort of semidirect product of  $\mathbf{S}$  and  $\mathbf{T}$ . This hyperfield is useful to describe real tropical geometry [JSY22].

In their recent paper [BL21a], Baker and Lorscheid have given a proof of Descartes' Rule of Signs using hyperfields. What they show is that given a real polynomial  $f(x) \in \mathbf{R}[x]$  with  $n$  positive roots, its image  $f^{\text{sign}}$  in  $\mathbf{S}[x]$  must be divisible by  $x - 1 \in \mathbf{S}[x]$  at least  $n$  times. The multiplicity  $\text{mult}_{x-1}^{\mathbf{S}}(f^{\text{sign}})$  of  $x - 1$  as a factor of  $f^{\text{sign}}$  therefore bounds the number of positive roots of  $f$  from above. Moreover, Baker and Lorscheid show that the maximal number of times one can factor out  $x - 1$  (i.e.  $\text{mult}_{x-1}^{\mathbf{S}}(f^{\text{sign}})$ ) is exactly the number of sign alterations as in Descartes' rule. Their theory also applies to the tropical hyperfield [BL21a] as well as other hyperfields like those associated to higher rank valuations or combining valuations and signs [Gun22a; Gun22b]. Akian-Gaubert-Tavikalipour have also carried out similar factorization results for polynomials over Rowan's "semiring systems" [AGT23].

#### 4.0.2 Linear factors of multivariate polynomials

An analogous formulation of Descartes' rule that has, so far, received little attention asks the following: given a polynomial  $f(\mathbf{x})$  in *several* variables with given support and coefficients with prescribed signs, what is the sharp upper bound for the number of its linear factors with a prescribed sign pattern? There is some relationship between this problem and the system-of-equation problem because the sparse resultant of a system of equations yields a single polynomial whose linear factors correspond (with multiplicity!) to the common solutions of the system. However, as shown in the example above, the signs of the resultant

are not uniquely determined from the signs of the system.

We approach the linear factor problem with the same strategy used by Baker and Lorscheid [BL21a] in the univariate case: for a real multivariate polynomial  $f(\mathbf{x}) \in \mathbf{R}[\mathbf{x}]$  and a “signed” degree-1 polynomial  $l = s_0 + \sum s_i x_i \in \mathbf{S}[\mathbf{x}]$ , we define  $\text{mult}_{\text{sign}^{-1}\{l\}}^{\mathbf{R}}(f)$  as the maximal number of degree-1 polynomials  $k$  with  $k^{\text{sign}} = l$  that we can factor out of  $f$ . Similarly, we define  $\text{mult}_l^{\mathbf{S}}(f^{\text{sign}})$  as the maximal number of times that we can factor  $l$  out of  $f^{\text{sign}}$  (as pointed out by Baker and Lorscheid [BL21a], one has to be careful here since quotients are not unique; see Definition 4.3.1).

**Theorem 4.A** (= Lemma 4.3.5). *We have*

$$\text{mult}_{\text{sign}^{-1}\{l\}}^{\mathbf{R}}(f) = \sum_k \text{mult}_k^{\mathbf{R}}(f) \leq \text{mult}_l^{\mathbf{S}}(f^{\text{sign}}),$$

where we sum over a set of representatives  $k$  of the image of  $\text{sign}^{-1}\{l\}$  in  $\mathbf{R}[\mathbf{x}]/\mathbf{R}^*$ , using unique factorization in  $\mathbf{R}[\mathbf{x}]$ .

Even in the one variable case, a real polynomial might have complex roots, meaning its observed number of positive roots could be less than the maximum allowed by its sign configuration. We define the relative multiplicity (with respect to sign) of  $l$  in a polynomial  $g \in \mathbf{S}[\mathbf{x}]$ , by

$$\text{mult}_l^{\text{sign}}(g) = \max\{\text{mult}_{\text{sign}^{-1}\{l\}}^{\mathbf{R}}(f) : f^{\text{sign}} = g\}.$$

Then the problem of finding the sharp upper bound for the number of linear factors with prescribed sign pattern in a polynomial with coefficients of prescribed signs becomes the question of determining the relative multiplicities  $\text{mult}_l^{\text{sign}}(g)$ . As an immediate consequence of the Theorem 4.A, we obtain the following corollary.

**Corollary 4.B** (= Proposition 4.3.29). *For  $l \in \mathbf{S}[\mathbf{x}]$  of degree 1 and  $g \in \mathbf{S}[\mathbf{x}]$  arbitrary we have*

$$\text{mult}_l^{\text{sign}}(g) \leq \text{mult}_l^{\mathbf{S}}(g).$$

Note that we prove Corollary 4.B in much greater generality, where  $\text{sign}$  is replaced by an arbitrary morphism of hyperfields.

**Example 4.0.2.** Let

$$f = (x - 1)(x - 2)(x^2 + 2) = x^4 - 3x^3 + 4x^2 - 6x + 4 \in \mathbf{R}[x].$$

Then  $f^{\text{sign}} = x^4 - x^3 + x^2 - x + 1 \in \mathbf{S}[x]$ . By Descartes' rule [BL21a, Theorem C], we have  $\text{mult}_{x-1}^{\mathbf{S}}(f^{\text{sign}}) = 4$  (the number of sign changes) but

$$\text{mult}_{\text{sign}^{-1}\{x-1\}}^{\mathbf{R}}(f) = \text{mult}_{x-1}^{\mathbf{R}} f + \text{mult}_{x-2}^{\mathbf{R}} f = 2.$$

On the other hand,  $\text{mult}_{x-1}^{\text{sign}}(f^{\text{sign}}) = 4$  since, for example,  $(x - 1)^4$  is a real polynomial in  $\text{sign}^{-1}\{f^{\text{sign}}\}$  with 4 positive roots.  $\diamond$

The sharpness in Descartes' rule of signs for univariate polynomials means precisely that  $\text{mult}_l^{\text{sign}}(g) = \text{mult}_l^{\mathbf{S}}(g)$  for any  $g \in \mathbf{S}[x]$ . In more than one variable, this is not true.

**Theorem 4.C** (= Example 4.3.31). *There exists a degree-3 polynomial  $g \in \mathbf{S}[x, y]$  and a degree-1 polynomial  $l \in \mathbf{S}[x, y]$  with*

$$\text{mult}_l^{\text{sign}}(g) < \text{mult}_l^{\mathbf{S}}(g).$$

In addition to not being a sharp bound for the relative multiplicity, we do not have a combinatorial description for the multiplicity  $\text{mult}_l^{\mathbf{S}}(g)$  like in the univariate case. This makes the multiplicity hard to compute. In practice, it is often sufficient to work with what we call the boundary multiplicity  $\partial\text{-mult}_l^{\mathbf{S}}(g)$ , which is the maximum of the multiplicities obtained after setting one of the variables to 0.

### 4.0.3 Subdivisions, Geometry and Multiplicities

Something that makes factoring tropical polynomials easier than factoring sign polynomials is that there is a geometry associated to tropical polynomials. A linear factor of a tropical polynomial corresponds to a tropical hyperplane within the tropical hypersurface defined by that polynomial. For a polynomial over  $\mathbb{TR}$ , we define enriched tropical hypersurfaces and consider the multiplicities of enriched linear hyperplanes. We call this the (*enriched*) *geometric multiplicity*. See Figure 4.5 for a demonstration of this idea.

Looking the opposite way, if we have a polynomial over  $\mathbf{S}$ , then we can try to perturb the coefficients a little bit to yield a polynomial over  $\mathbb{TR}$ . Where the geometric multiplicity tells us to exploit an existing subdivision of the Newton polytope, here we *impose* a subdivision by perturbing coefficients. We call this the *perturbation multiplicity*,  $\epsilon\text{-mult}_l^{\mathbf{S}}(g)$ . The perturbation multiplicity is a lower bound on the hyperfield multiplicity because factoring with respect to an imposed subdivision is stricter than factoring irrespective of a subdivision. Moreover, it is also a lower bound on the relative multiplicity because the factors with the imposed subdivision can be lifted to, say, the real Puiseux series.

**Theorem 4.D** (= Corollary 4.3.35, Proposition 4.3.29, Corollary 4.3.7, Theorem 4.3.42). *If  $f \in \mathbf{S}[\mathbf{x}]$  is dense—meaning every monomial of degree  $\leq \deg f$  has a non-zero coefficient—and  $l \in \mathbf{S}[\mathbf{x}]$  has degree 1, then we have*

$$\epsilon\text{-mult}_l^{\mathbf{S}}(f) \leq \text{mult}_l^{\text{sign}}(f) \leq \text{mult}_p^{\mathbf{S}}(f) \leq \partial\text{-mult}_p^{\mathbf{S}}(f).$$

*If  $f$  is dense of degree two in two variables, then we have equality everywhere.*

#### 4.0.4 Systems of equations

Let  $\varphi: K \rightarrow H$  be a morphism from a field  $K$  to a hyperfield  $H$ . Given polynomials  $g_1, \dots, g_n \in H[x_1, \dots, x_n]$  and  $\mathbf{h} \in (H^*)^n$  we denote by

$$N_{\mathbf{h}}^{\varphi}(g_1, \dots, g_n)$$

the maximal number of solutions  $\mathbf{x}$  with  $\varphi(\mathbf{x}) = \mathbf{h}$  that a system  $f_1(\mathbf{x}) = \dots = f_n(\mathbf{x}) = 0$  of equations over  $K$  with finite solution set (in  $\overline{K}$ ) and  $f_i^{\text{sign}} = g_i$  can have. For  $K = \mathbf{C}$  and  $H = \mathbf{K}$ , the answer is given by the Bernstein-Khovanskii-Kushnirenko (BKK) theorem. For  $\varphi = \text{sign}: \mathbf{R} \rightarrow \mathbf{S}$  these are precisely the numbers studied by Itenberg and Roy [IR96]. Let  $f_i \in K[\mathbf{x}]$  with  $f_i^{\varphi} = g_i$ . Introducing an auxiliary linear form  $l = 1 + y_1x_1 \dots y_nx_n$  with indeterminate coefficients and taking the (mixed sparse) resultant  $R_{f_1, \dots, f_n} \in K[\mathbf{y}]$  of  $f_1, \dots, f_n, l$ , finding solutions to the system of equations

$$f_1(\mathbf{x}) = \dots = f_n(\mathbf{x}) = 0$$

is equivalent to finding linear factors of  $R$ . More precisely, if the coefficients of  $f_1, \dots, f_n$  are generic, then we have

$$R_{f_1, \dots, f_n} \propto \prod_{\mathbf{a} \in V(f_i) \subset (\overline{K}^*)^n} (1 + a_1y_1 + \dots + a_ny_n),$$

with the proportionality being up to a unit. The polynomial  $R_{f_1, \dots, f_n}$  is a specialization of a polynomial  $R_{A_1, \dots, A_n} \in \mathbf{Z}[\mathbf{y}]$  which is determined just by the support sets  $A_i = \text{supp}(f_i)$ . Resultants allow us to apply our techniques to systems of equations:

**Theorem 4.E** (=Theorem 4.4.10). *Let  $R_{g_1, \dots, g_n} \subseteq H[\mathbf{y}]$  be the set of polynomials obtained by evaluating the resultant  $\tilde{R}_{A_1, \dots, A_n} \in \mathbf{Z}[\mathbf{y}]$  at the coefficients of the  $g_i$ , where  $A_i = \text{supp}(g_i)$ .*



Moreover, let  $l_{\mathbf{h}} = 1 + \sum h_i y_i$ . Then we have

$$N_{\mathbf{h}}^{\varphi}(g_1, \dots, g_n) \leq \max\{\text{mult}_{l_{\mathbf{h}}}^H(r) : r \in R_{g_1, \dots, g_n}\}.$$

We observe in several examples that the bound is far from sharp. However, applying the theorem to the counterexample to the Itenberg-Roy conjecture given by Li and Wang [LW98] yields the correct bound and shows that Li and Wang have in fact chosen an example where the number of positive solutions is maximal for the given choices of supports and signs.

We also study the numbers  $N_{\mathbf{h}}^{\varphi}(g_1, \dots, g_n)$  when  $\varphi$  is a valuation and  $H = \mathbf{T}$  or  $H = \mathbf{TR}$ , depending on whether  $K$  is algebraically closed or real closed. In this case each of the  $g_i$  defines a tropical hypersurface  $V(g_i)$  and we study the case where the intersection  $\bigcap_{i=1}^n V(g_i)$  is transverse at the image of  $\mathbf{h}$  in  $\mathbf{R}^n$  (this means that if  $H = \mathbf{TR}$  we apply the projection  $\mathbf{TR} \rightarrow \mathbf{T}$  coordinate-wise). Using a result by Sturmfels on initial forms of resultants [Stu94a], we prove the following result.

**Theorem 4.F** (= Theorem 4.4.6). *Assume that  $H = \mathbf{T}$ , that  $\varphi$  is a valuation, and that  $\bigcap_{i=1}^n V(g_i)$  meets transversely at  $\mathbf{h}$ . Then  $N_{\mathbf{h}}^{\varphi}(g_1, \dots, g_n)$  equals the multiplicity of the tropical intersection product  $V(g_1) \cdots V(g_n)$  at  $\mathbf{h}$ . If  $H = \mathbf{TR}$  and  $\varphi$  is the “signed valuation”, then  $N_{\mathbf{h}}^{\varphi}(g_1, \dots, g_n)$  equals 1 if  $\mathbf{h}$  is an alternating point of  $V(g_1) \cdots V(g_n)$  and 0 otherwise (see page 171 for a definition of alternating).*

Combining Theorem 4.F with the completeness of the theory of real closed fields, we obtain a combinatorial multiplicity  $\epsilon\text{-}N_{\mathbf{h}}^{\text{sign}}(g_1, \dots, g_n)$  in terms of transverse tropical intersections or, dually, mixed Newton subdivisions. It is analogous to the combinatorial multiplicities  $\epsilon\text{-}\text{mult}_l(g)$  and agrees with the numbers appearing in the conjecture of Itenberg and Roy. Our methods allow us to reprove Itenberg and Roy’s lower bound.

**Corollary 4.G** ([IR96], Corollary 4.4.8). *For  $g_1, \dots, g_n \in \mathbf{S}[x_1, \dots, x_n]$  and  $\mathbf{h} \in (\mathbf{S}^*)^n$  we*

have

$$\epsilon\text{-}N_{\mathbf{h}}^{\text{sign}}(g_1, \dots, g_n) \leq N_{\mathbf{h}}^{\text{sign}}(g_1, \dots, g_n).$$

#### 4.0.5 Acknowledgement

We thank Matt Baker and Josephine Yu for numerous insightful discussions. We thank Matt Baker and Oliver Lorscheid for providing comments on an earlier draft.

This project has received funding from the Deutsche Forschungsgemeinschaft (DFG, German Research Foundation) TRR 326 *Geometry and Arithmetic of Uniformized Structures*, project number 444845124; and *From Riemann surfaces to tropical curves (and back again)*, project number 456557832.

#### 4.0.6 Notation

### **Hyperfields**

<b>K</b>	Krasner hyperfield 4.1.3
<b>S</b>	Sign hyperfield 4.1.4
<b>T</b>	Tropical hyperfield 4.1.5
$H \rtimes \Gamma, \mathbf{TR}$	Tropical extensions, tropical real hyperfield 4.1.6
$ht^w = (h, w)$	Element of a tropical extension

## Maps and Morphisms

$\text{sign}: K \rightarrow \mathbf{S}$	The sign of an element of a real field 4.1.17
$\nu: K \rightarrow \mathbf{T}$	A (Krull) valuation 4.1.14
$f^\varphi, f^{\text{sign}}, f^\nu$ , etc.	Apply $\varphi, \text{sign}, \nu$ , etc. to each coefficient 4.2.4
$\text{ac}: K \rightarrow \kappa$	Angular component map for a valued field 4.1.16
$\text{ac}: H \rtimes \Gamma \rightarrow H$	Angular component map for a tropical extension 4.1.14
$\nu_{\text{ac}}: K \rightarrow \kappa \rtimes \Gamma$	Refined valuation 4.1.16
$\nu_{\text{sgn}}: K \rightarrow \mathbf{S} \rtimes \Gamma$	Signed valuation 4.1.3
PF	Polynomial function map 4.2.13

## Multiplicities

$\epsilon\text{-mult}^H$	Perturbation multiplicity 4.3.34
$\text{mult}^\varphi$	Relative multiplicity 4.3.28
$\text{mult}^H$	Hyperfield multiplicity 4.3.1
$\partial\text{-mult}^H$	Boundary multiplicity 4.3.6
$\text{gmult}^H$	$H$ -enriched geometric multiplicity 4.3.20
$N_h^\varphi$	Multiplicity for systems of equations 4.4
$\epsilon\text{-}N_h$	Perturbation multiplicity for systems of equations 4.4.9

### 4.1 Fields and Hyperfields

Hyperfields are algebraic objects which are well-suited to capture the arithmetic of signs (having forgotten the absolute value) or the arithmetic of absolute values (having forgotten the signs). One can think of a hyperfield as a field but where adding pairs of elements gives a non-empty set subject to the usual rules of commutativity, associativity, distributivity, etc. The axiom labeled “reversible” behaves as an ersatz subtraction.

**Definition 4.1.1.** A *hyperfield* is a tuple  $H = (H, 0, 1, \cdot, \boxplus)$  where

- $0 \neq 1$ ,

- $H^* = (H \setminus \{0\}, 1, \cdot)$  is an Abelian group,
- 0 is an absorbing element:  $0 \cdot a = a \cdot 0$  for all  $a \in H$ .

Additionally, the *hyperaddition*  $\boxplus$  is a multivalued operation, that is a function  $\boxplus: H \times H \rightarrow \{\text{nonempty subsets of } H\}$ , such that for all  $a, b \in H$ :

- $a \boxplus b = b \boxplus a$  (commutative),
- $0 \boxplus a = \{a\}$  (identity),
- there is a unique element  $-a$  such that  $0 \in a \boxplus (-a)$  (inverses),
- $\bigcup\{a \boxplus t : t \in b \boxplus c\} = \bigcup\{t \boxplus c : t \in a \boxplus b\}$  (associative)
- $a \in b \boxplus c \iff -b \in (-a) \boxplus c$  (reversible)

Repeated addition is treated monadically, using the power set monad. This means that notationally we will identify elements of  $H$  and singletons and repeated hyperaddition is flattened by unions—for example,  $a \boxplus (b \boxplus c) = (a \boxplus b) \boxplus c$  means exactly what the associativity axiom says.

In what follows, we will rarely need to work directly with the axioms above because we will use a common and more familiar subtype of hyperfields called quotient hyperfields. All the hyperfields used in this chapter are quotient hyperfields.

**Definition 4.1.2.** Let  $F$  be a field and let  $G$  be a subgroup of the group of units  $F^*$ . The *quotient hyperfield*  $F/G$  is the quotient set with the induced multiplication and the hyperaddition defined by

$$aG \boxplus bG = \{(c + d)G : c \in aG \text{ and } d \in bG\}.$$

If instead  $F$  was a ring, then  $F/G$  is a *quotient hyperring*.

For simplicity of notation, we will often use the same symbols in  $F$  to denote their equivalence classes in  $F/G$ . Furthermore, if  $a \boxplus b$  is a singleton, we will omit the braces which indicate that the sum is a set.

**Example 4.1.3.** If  $F$  is any field with at least 3 elements, then the hyperfield  $\mathbf{K} = F/F^* = \{0, 1\}$  is called the *Krasner hyperfield* after Marc Krasner. It has the following arithmetic:

$$\begin{array}{c|cc} \cdot & 0 & 1 \\ \hline 0 & 0 & 0 \\ 1 & 0 & 1 \end{array} \quad \begin{array}{c|cc} \boxplus & 0 & 1 \\ \hline 0 & 0 & 1 \\ 1 & 1 & \mathbf{K} \end{array}$$

The Krasner hyperfield is the hyperfield analogue of the Boolean semifield which has the same arithmetic except that  $1 + 1 = 1$  instead of  $\{0, 1\}$ .  $\diamond$

**Example 4.1.4.** The *sign hyperfield*  $\mathbf{S} = \mathbf{R}/\mathbf{R}_{>0} = \{0, 1, -1\}$  is a quotient of the real numbers by the subgroup of positive real numbers. The arithmetic on  $\mathbf{S}$  is given by the following tables.

$$\begin{array}{c|ccc} \cdot & 0 & 1 & -1 \\ \hline 0 & 0 & 0 & 0 \\ 1 & 0 & 1 & -1 \\ -1 & 0 & -1 & 1 \end{array} \quad \begin{array}{c|ccc} \boxplus & 0 & 1 & -1 \\ \hline 0 & 0 & 1 & -1 \\ 1 & 1 & 1 & \mathbf{S} \\ -1 & -1 & \mathbf{S} & -1 \end{array}$$

This arithmetic encodes rules like “positive times negative is negative”, “negative plus negative is negative,” and “positive plus negative can be anything.”  $\diamond$

**Example 4.1.5.** If  $(F, |\cdot|)$  is a field with an absolute value, then we can take its quotient by the group of elements with absolute value 1 to create a hyperfield whose underlying set is the image  $|F|$ . The resulting hyperfield is called a *triangle hyperfield* in the Archimedean case or an *ultratriangle hyperfield* in the non-Archimedean case. Such hyperfields were first described by Viro who showed how they can be used to do computations in tropical geometry [Vir11].

The most common such hyperfield is where  $|\cdot|$  is a non-Archimedean valuation whose image is  $\mathbf{R}_{\geq 0}$ . For our purposes, it will be more convenient to use the image of the associated valuation  $\text{val}(x) = -\log|x|$  (i.e. the set  $\mathbf{R} \cup \{\infty\}$ ) as the base set instead. We call this the *tropical hyperfield*, denoted by  $\mathbf{T}$ , where the arithmetic is given by  $a \cdot_{\mathbf{T}} b = a +_{\mathbf{R}} b$  and

$$a \boxplus b = \begin{cases} \min\{a, b\} & a \neq b, \\ [a, \infty] & a = b. \end{cases} \quad \diamond$$

#### 4.1.1 Tropical Extensions

**Example 4.1.6.** If  $H$  is any hyperfield and  $\Gamma$  is an ordered Abelian group, then we can extend  $\Gamma$  by  $H$  to get a version of the ultratriangle hyperfields of Example 4.1.5 “with coefficients in  $H$ .”

Define the set

$$H \rtimes \Gamma = \{(h, \gamma) : h \in H^*, \gamma \in \Gamma\} \cup \{\infty\}.$$

We will also use the notation  $ht^\gamma = (h, \gamma)$  to better emphasize the relation between these extensions of hyperfields and extensions of a valued field  $K$  to a valuation on  $K(t)$  or  $K((t))$  or similar (Remark 4.1.9).

Multiplication is defined by  $(h_1 t^{\gamma_1})(h_2 t^{\gamma_2}) = (h_1 h_2) t^{\gamma_1 + \gamma_2}$  and the hypersum of  $h_1 t^{\gamma_1}$  and  $h_2 t^{\gamma_2}$  is defined as

$$\begin{cases} h_1 t^{\gamma_1} & \gamma_1 < \gamma_2, \\ h_2 t^{\gamma_2} & \gamma_2 < \gamma_1, \\ (h_1 \boxplus h_2) t^{\gamma_1} & \gamma_1 = \gamma_2 \text{ and } 0_H \notin h_1 \boxplus h_2, \\ (h_1 \boxplus h_2) t^{\gamma_1} \cup \{ht^\gamma : h \in H, \gamma > \gamma_1\} & \gamma_1 = \gamma_2 \text{ and } 0_H \in h_1 \boxplus h_2. \end{cases} \quad (4.1)$$

We call this construction a *tropical extension*. \(\diamond\)

**Remark 4.1.7.** *The hyperfield  $\mathbf{TR} = \mathbf{S} \rtimes \mathbf{R}$  is called the tropical real hyperfield. This hyperfield and other specific tropical extensions were first described in Viro's work [Vir11]. The idea of extending ordered groups by a hyperfield appeared in the work of Bowler and Su [BS21]. The tropical real hyperfield has also been used to describe real tropical geometry (e.g. [JSY22]).*

**Remark 4.1.8.** *In terms of tropical extensions, we also have  $\mathbf{T} = \mathbf{K} \rtimes \mathbf{R}$  and, in fact, every ultratriangle hyperfield described in Example 4.1.5 is of the form  $\mathbf{K} \rtimes \Gamma$  where  $\Gamma$  is the image of the non-Archimedean valuation or absolute value.*

**Remark 4.1.9.** *If  $H = F/G$  as in Definition 4.1.2, then we can form the field of Hahn series*

$$F[[t^\Gamma]] = \left\{ \sum_{i \in I} a_i t^i : a_i \in F \text{ and } I \text{ is a well-ordered subset of } \Gamma \right\}.$$

*There is a natural valuation  $\nu$  on  $F[[t^\Gamma]]$  given by  $\nu(\sum_{i \in I} a_i t^i) = \min\{i \in I : a_i \neq 0\}$ .*

*Now define*

$$G_0 = \left\{ f = \sum_{i \in I} a_i t^i \in F[[t^\Gamma]] : \nu(f) = 0_\Gamma \text{ and } a_0 \in G \right\}.$$

*The hyperfield  $H \rtimes \Gamma$  is isomorphic to  $F[[t^\Gamma]]/G_0$ .*

**Remark 4.1.10.** *Bowler and Su [BS21] have a more general construction of a hyperfield from any extension*

$$1 \rightarrow H^* \rightarrow G \rightarrow \Gamma \rightarrow 0$$

*of groups in which the conjugation operation of  $G$  on  $H^*$  extends to an action of  $G$  on  $H$  via automorphisms of hyperfields. In this context,  $H \rtimes \Gamma$  is the hyperfield corresponding to the split extension of  $\Gamma$  by  $H^*$ . Moreover, Bowler and Su show if  $H \in \{\mathbf{K}, \mathbf{S}\}$ , then all such extensions are split [BS21, Theorem 4.17]. In a paper of the second author (TG), Bowler and Su's construction is described using the language of ordered blueprints [Gun22b] (also chapter 3).*

**Remark 4.1.11.** We can make the same definition if  $\Gamma$  is an ordered semigroup instead of a group. If  $\Gamma$  is not a group, then  $H \rtimes \Gamma$  will be a hyperring instead of a hyperfield. This will be useful for us to talk about valuation hyperrings, which take the form  $H \rtimes \Gamma_{\geq 0}$  with  $\Gamma_{\geq 0} = \{\gamma \in \Gamma : \gamma \geq 0\}$ .

### 4.1.2 Morphisms

**Definition 4.1.12.** A morphism between two hyperfields  $H_1$  and  $H_2$  is a map  $\varphi: H_1 \rightarrow H_2$  such that for all  $x, y \in H_1$ :

- $\varphi(0) = 0$ ,
- $\varphi(1) = 1$ ,
- $\varphi(xy) = \varphi(x)\varphi(y)$ ,
- $\varphi(x \boxplus y) \subseteq \varphi(x) \boxplus \varphi(y)$ .

**Lemma 4.1.13.** If  $\varphi: H_1 \rightarrow H_2$  is a morphism of hyperfields and we have  $A \in \boxplus_{i=1}^n B_i C_i$  in  $H_1$ , then

$$\varphi(A) \in \boxplus_{i=1}^n \varphi(B_i)\varphi(C_i).$$

*Proof.* By induction. □

### 4.1.3 Valuations

**Definition 4.1.14.** Let  $H$  be a hyperfield. A valuation on  $H$  is a morphism

$$\nu: H \rightarrow \mathbf{K} \rtimes \Gamma$$

of hyperfields for some totally ordered Abelian group  $\Gamma$ .

**Example 4.1.15.**



(a) If  $K$  is a field and  $\nu: K \rightarrow \mathbf{K} \rtimes \Gamma$  is a map, then  $\nu$  is a valuation in the sense of Definition 4.1.14 if and only if it is a valuation in the usual sense.

(b) For every hyperfield  $H$  and every totally ordered Abelian group  $\Gamma$ , we obtain a valuation

$$\nu: H \rtimes \Gamma \rightarrow \mathbf{K} \rtimes \Gamma, \quad (h, \gamma) \mapsto \gamma.$$

The map

$$\text{ac}: H \rtimes \Gamma \rightarrow H, \quad (h, \gamma) \mapsto h$$

is not a morphism of hyperfields in general. We call it the *angular component map*

(c) For every hyperfield  $H$  there is a unique morphism of hyperfields

$$\nu_0: H \rightarrow \mathbf{K}.$$

As  $\mathbf{K} = \mathbf{K} \rtimes 0$ , this is a valuation with value group 0, the *trivial valuation*.  $\diamond$

**Definition 4.1.16.** Let  $K$  be a valued field with valuation  $\nu: K \rightarrow \mathbf{K} \rtimes \Gamma$  and residue field  $\kappa$ . Assume that the valuation  $\nu: K \rightarrow \mathbf{T}$  splits, that is that there exists a morphism of Abelian groups  $\psi: \Gamma \rightarrow K^*$  with  $\nu(\psi(\gamma)) = t^\gamma$ . By abuse of notation, we denote  $\psi(\gamma) = t^\gamma$ . We define the *angular component* (with respect to the given splitting)  $\text{ac}(a)$  of  $a \in K^*$  by

$$\text{ac}(a) = \overline{t^{-\nu(a)}a} \in \kappa,$$

where the bar indicates that we take the class in the residue field. We also set  $\text{ac}(0) = 0$ . We can then refine the valuation to a morphism of hyperfields

$$\nu_{\text{ac}}: K \rightarrow \kappa \rtimes \mathbf{R}, \quad a \mapsto \begin{cases} \text{ac}(a)t^{\nu(a)} & , \text{ if } a \neq 0 \\ 0 & , \text{ else.} \end{cases}$$

By definition, we have  $\text{ac}(a) = \text{ac}(\nu_{\text{ac}}(a))$  for every  $a \in K$ .

Recall that a *real closed field* is a field  $K$  which is not algebraically closed and whose algebraic closure is  $K(i) = K[x]/(x^2 + 1)$ . Every real closed field is an ordered field, where the non-negative elements are precisely the squares. A *valued real closed field* is a real closed field  $K$  together with a valuation

$$\nu: K \rightarrow \mathbf{K} \rtimes \Gamma$$

such that  $0 < a < b$  implies  $\nu(a) \geq \nu(b)$ . In this case, the residue field  $\kappa$  is real closed again. If  $\nu$  is surjective, then it splits [AGS20, Lemma 2.4]. Since the angular component is multiplicative, we have

$$\text{sign}(a) = \text{sign}(\text{ac}(a))$$

for all  $a \in K$ . We define the *signed valuation*  $\nu_{\text{sgn}}$  as the composite

$$K \xrightarrow{\nu_{\text{ac}}} \kappa \rtimes \Gamma \xrightarrow{\text{sign} \rtimes \Gamma} \mathbf{S} \rtimes \Gamma.$$

By what we just observed, we have  $\nu(\nu_{\text{sgn}}(a)) = \nu(a)$  and  $\text{ac}(\nu_{\text{sgn}}(a)) = \text{sign}(a)$  for all  $a \in K$ .

#### 4.1.4 Real fields

**Definition 4.1.17.** A hyperfield  $R$ , is called *real* if it is equipped with a morphism  $\text{sign}: R \rightarrow \mathbf{S}$ . We call  $\text{sign}$  a sign map on  $R$ .

**Remark 4.1.18.** *Definition 4.1.17 mirrors Definition 4.1.14 and, in fact, both are special cases of “valuations” in the theory of ordered blueprints [Lor18c, Chapter 6].*

**Remark 4.1.19.** *For any ordering  $\leq$  on a field  $R$ , there exists a unique morphism  $\varphi: R \rightarrow \mathbf{S}$  such that  $\varphi(x) = 1$  if  $x > 0$  and  $\varphi(x) = -1$  if  $x < 0$ . In fact, if  $R$  is a ring, then morphisms  $s: R \rightarrow \mathbf{S}$  correspond to pairs consisting of a prime ideal  $\ker(s)$  and a total order on*

$R/\ker(s)$  [CC11, Proposition 2.12]. This concept can be extended to the language of schemes [Jun21].

**Remark 4.1.20.** Given a morphism from a field  $K$  to  $\mathbf{TR}$ , we get both a total order on  $K$  defined by the composition  $K \rightarrow \mathbf{TR} \xrightarrow{\text{ac}} \mathbf{S}$  and a valuation on  $K$  defined by  $K \rightarrow \mathbf{TR} \xrightarrow{\nu} \mathbf{T}$ . The converse does not need to hold. For instance,  $\mathbf{Q}$  has a natural total order and various  $p$ -adic valuations, but these  $p$ -adic valuations are not compatible with the total order. For a description of what makes a valuation compatible with a total order, we refer the reader to discussions in other papers [Gun22a; AGT23].

## 4.2 Polynomials over hyperfields

**Definition 4.2.1.** If  $H$  is a hyperfield and  $\mathbf{x} = x_1, \dots, x_n$  are indeterminants, we define the set of *polynomials*

$$H[\mathbf{x}] = \left\{ \sum a_{\mathbf{m}} \mathbf{x}^{\mathbf{m}} : \mathbf{m} \in \mathbf{Z}_{\geq 0}^n, \text{ with finite support} \right\},$$

where we use multi-index notation  $\mathbf{x}^{\mathbf{m}} = x_1^{m_1} \cdots x_n^{m_n}$  and the *support* of  $f = \sum a_{\mathbf{m}} \mathbf{x}^{\mathbf{m}}$  is the set  $\text{supp}(f) = \{\mathbf{m} \in \mathbf{Z}_{\geq 0}^n : a_{\mathbf{m}} \neq 0\}$ . Addition and multiplication (defined by convolution) give set-valued operations, meaning that  $H[\mathbf{x}]$  is not, in general, a hyperfield.

If  $f, g, h \in H[\mathbf{x}]$  are such that  $f \in g \cdot h$ , we call this a *factorization* of  $f$ . Concretely, if the coefficients of  $f, g, h$  are  $a_{\mathbf{m}}, b_{\mathbf{m}}, c_{\mathbf{m}}$ , respectively, this means that for every  $\mathbf{m} \in \mathbf{Z}_{\geq 0}^n$  we have,

$$a_{\mathbf{m}} \in \bigsqcup_{n+p=\mathbf{m}} b_{\mathbf{n}} c_{\mathbf{p}}.$$

If  $f = \sum a_{\mathbf{m}} \mathbf{x}^{\mathbf{m}} \in H[\mathbf{x}]$  and  $\mathbf{z} \in H^n$ , then  $f(\mathbf{z})$  denotes the evaluation of  $f$  at  $\mathbf{z}$ , which is the set  $\bigsqcup a_{\mathbf{m}} \mathbf{z}^{\mathbf{m}}$ .

**Remark 4.2.2.** Because addition in hyperfields is set-valued, when we construct polynomials, both multiplication and addition are set-valued. We will make use of these operations, but we

will not try to develop a broader theory of ring-like algebras with multivalued multiplication and addition for two reasons. First,  $H[\mathbf{x}]$  is generally not “free” in the usual understanding of the adjective. Second, there is an existing theory due to Lorscheid of “ordered blueprints” which contains both hyperfields and free algebras, and which is a nicer and more natural setting to discuss polynomial algebras over hyperfields [Lor18c], [BL21a, Appendix]. See [Gun22b] for a demonstration of how to rephrase hyperfield notation and multiplicities in terms of ordered blueprints.

**Definition 4.2.3.** In some examples, it will be convenient to use a grid notation for polynomials in two variables, where we put the coefficient of  $x^i y^j$  at position  $(i, j)$  and an empty space for a 0 coefficient. For instance, the grid

$$f = \begin{array}{ccc} & + & \\ & - & \\ + & - & + \end{array}$$

denotes the polynomial  $+1 - x - y + x^2 + y^2 \in \mathbf{S}[x, y]$ .

**Definition 4.2.4.** Let  $\varphi: H_1 \rightarrow H_2$  be a morphism of hyperfields and let  $f \in H_1[\mathbf{x}]$ . We denote by  $f^\varphi$  the polynomial in  $H_2[\mathbf{x}]$  obtained by applying  $\varphi$  to all coefficients of  $f$ .

**Corollary 4.2.5.** If  $\varphi: H_1 \rightarrow H_2$  is a morphism of hyperfields, and  $f \in g \cdot h$  in  $H_1[\mathbf{x}]$ , then  $f^\varphi \in g^\varphi \cdot h^\varphi$ .

*Proof.* This follows directly from Lemma 4.1.13. □

**Definition 4.2.6.** Given two sets of polynomials  $H_1[\mathbf{x}]$  and  $H_2[\mathbf{x}]$ , by a *diagonal transformation*,  $\Phi: H_1[\mathbf{x}] \rightarrow H_2[\mathbf{x}]$ , we mean a function which is a composite of a map as in Definition 4.2.4 and a *diagonal monomial substitution* of the form  $\mathbf{x} \mapsto \mathbf{a}\mathbf{x}^{\mathbf{k}} = (a_1 x_1^{k_1}, \dots, a_n x_n^{k_n})$  for some  $\mathbf{a} \in H_2^n$  and  $\mathbf{k} \in (\mathbf{Z}_{>0})^n$ .

**Remark 4.2.7.** More general monomial substitutions do not necessarily lead to element-to-element maps. For instance, substituting  $y \mapsto x$  in  $x + y$  yields  $(1 \boxplus 1)x$ . In the next lemma,

we could also consider substitutions coming from injective semigroup homomorphisms  $\mathbb{N}^n \rightarrow \mathbb{N}^n$  instead of just a diagonal ones but since the only substitutions we use have the form  $\mathbf{x} \mapsto \mathbf{ax}$  or maybe relabelling some variables, it just makes for easier notation to only consider diagonal substitutions.

**Lemma 4.2.8.** *If  $f \in g \cdot h$  and  $(x_i) \mapsto (a_i x_i^{k_i})$  is a diagonal monomial transformation, then  $f(\mathbf{ax}^k) \in g(\mathbf{ax}^k) \cdot h(\mathbf{ax}^k)$ .*

*Proof.* Let  $A_m, B_n, C_p$  be the coefficients of  $f, g, h$ , respectively. So we have

$$A_m \in \bigsqcup_{m=n+p} B_n C_p$$

for all  $m \in \mathbb{Z}_{\geq 0}$ . This implies that

$$A_m \mathbf{a}^{mk} \in \bigsqcup_{m=n+p} B_n C_p \mathbf{a}^{nk+pk}$$

which is the condition that  $f(\mathbf{ax}^k) \in g(\mathbf{ax}^k) \cdot h(\mathbf{ax}^k)$ . □

Combining Corollary 4.2.5 and Lemma 4.2.8, we obtain the following:

**Corollary 4.2.9.** *If  $\Phi: H_1[\mathbf{x}] \rightarrow H_2[\mathbf{x}]$  is a diagonal transformation and  $f \in g \cdot h \in H_1[\mathbf{x}]$ , then  $\Phi(f) \in \Phi(g) \cdot \Phi(h)$ .*

#### 4.2.1 Newton Polygons

A useful tool to understand the combinatorics of polynomials over valued (hyper)fields is the *Newton polytope*.

**Definition 4.2.10.** Let  $f = \sum a_m \mathbf{x}^m \in H[\mathbf{x}]$ . We call the convex hull of  $\text{supp}(f) \subset \mathbb{R}^n$  the *Newton polytope*, denoted  $\text{Newt}(f)$ . We say that  $f$  is *dense* if  $\text{supp}(f) = \text{Newt}(f) \cap \mathbb{Z}^n$ . When  $H$  has a valuation  $v: H \rightarrow \mathbb{T}$ , we furthermore have a subdivision of  $\text{Newt}(f)$ , constructed as follows.

Take the set of points

$$\mathcal{S} = \{(m, v(a_m)) \in \mathbf{Z}^m \times \mathbf{R} : m \in \text{supp}(f)\}.$$

The *lower convex hull* of  $\mathcal{S}$  is the intersection of all “lower-halfspaces” containing  $\mathcal{S}$ . Here, a lower-halfspace is a halfspace cut out by a “lower-inequality”:  $\{p \in \mathbf{R}^{m+1} : \langle u, p \rangle + c \geq 0\}$  for some  $u \in \mathbf{R}^m \times \mathbf{R}_{\geq 0}$  and  $c \in \mathbf{R}$ . This lower convex hull is sometimes called the *extended Newton polytope* of  $f$ .

By projecting the faces of this extended Newton polytope into the first  $m$  coordinates, we obtain a subdivision of  $\text{Newt}(f)$ . For polynomials over valued hyperfields,  $\text{Newt}(f)$  refers to both the polytope and the subdivision, where appropriate.

**Example 4.2.11.** Consider the polynomial  $1 + x + y + x^2 + xy + 1y^2 \in \mathbf{T}[x, y]$ . The edges and vertices of the extended Newton polytope are drawn in Figure 4.2 in greyscale and the associated subdivision is drawn beneath it in purple. ◇

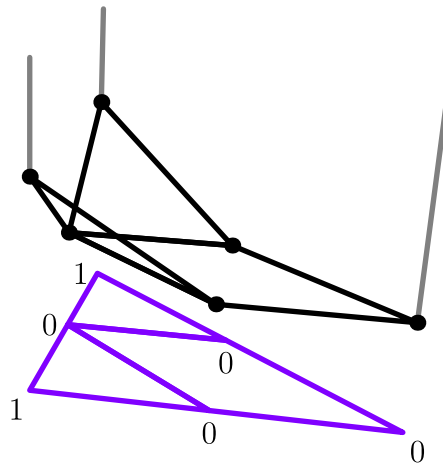

Figure 4.2: Extended Newton polytope of the polynomial  $f = 1 + x + y + x^2 + xy + 1y^2 \in \mathbf{T}[x, y]$  and associated subdivision of  $\text{Newt}(f)$ . Numbers indicate the valuation of the corresponding coefficient.

**Definition 4.2.12.** The Newton polytope of  $1 + \sum_{i=1}^n x_i$  is the standard  $(n + 1)$ -simplex, denoted  $\Delta_{n+1}$ . The Newton polytope of  $1 + \sum_{i=1}^n x_i^d$  is denoted  $d\Delta_{n+1}$  and is the  $d$ -fold

Minkowski sum of  $\Delta_{n+1}$ . Concretely,

$$d\Delta_{n+1} = \left\{ \mathbf{a} \in \mathbf{R}_{\geq 0}^n : \sum a_i \leq d \right\}.$$

Given a polynomial  $f \in H[\mathbf{x}]$ , we say that  $f$  has *Newton-degree*  $d$  if  $\text{Newt}(f) = d\Delta_{n+1}$ .

#### 4.2.2 Polynomial Functions

**Definition 4.2.13.** Every polynomial  $f = \sum a_m \mathbf{x}^m \in \mathbf{T}[x_1, \dots, x_n]$  determines a tropical polynomial function  $\text{PF}_f$ , given by

$$\text{PF}_f: \mathbf{R}^n \rightarrow \mathbf{R}, \quad \mathbf{x} \mapsto \min\{a_m + \langle \mathbf{m}, \mathbf{x} \rangle : \mathbf{m} \in \mathbf{Z}_{\geq 0}^n\}.$$

Tropical polynomial functions are piecewise linear with integral slopes. We say that a monomial  $a_m \mathbf{x}^m$  of  $f$  is *essential* if  $\text{PF}_f(\mathbf{x}) = a_m + \langle \mathbf{m}, \mathbf{x} \rangle$  on some open subset of  $\mathbf{R}^n$ . In general, the polynomial  $f$  is not determined by  $\text{PF}_f$ , but all of its essential monomials are. More precisely, if  $f^{\text{ess}}$  denotes the sum of the essential monomials of  $f$ , then  $\text{PF}_f = \text{PF}_{f^{\text{ess}}}$ . It follows that for two polynomials  $f, g \in \mathbf{T}[\mathbf{x}]$  we have  $\text{PF}_f = \text{PF}_g$  if and only if  $f^{\text{ess}} = g^{\text{ess}}$ . We say that  $f$  is *strictly convex* if  $f = f^{\text{ess}}$ . Note that we always have  $\text{Newt}(f) = \text{Newt}(f^{\text{ess}})$ .

**Remark 4.2.14.** *Polynomial functions use arithmetic from the tropical semifield  $\bar{\mathbf{R}}$  where  $a \oplus b$  is the single element  $\min\{a, b\}$ . In Lorscheid's theory of ordered blueprints, there is a functor which relates the hyperfield  $\mathbf{T}$  with the semifield  $\bar{\mathbf{R}}$ . Consider the order  $\leq$  on  $\mathbf{T}$ , defined by  $a \leq b + c$  if  $a \in b \boxplus c$ . If we add the relation  $1 + 1 \leq 1$ , we obtain  $\bar{\mathbf{R}}$ .*

**Lemma 4.2.15.** *Let  $f, g \in \mathbf{T}[\mathbf{x}]$  be polynomials and let  $h \in f \cdot g$ . Then we have*

$$\text{PF}_h = \text{PF}_f + \text{PF}_g.$$

*Proof.* Let  $a_m, b_m$  and  $c_m$  denote the coefficients of  $f, g$ , and  $h$ , respectively. Let  $\mathbf{w} \in \mathbf{R}^n$

be generic; more precisely, we require that  $\mathbf{w}$  is contained in the dense open subset of  $\mathbf{R}^n$  where there exist unique  $\mathbf{m}_1, \mathbf{m}_2 \in \mathbf{Z}_{\geq 0}^n$  such that  $\text{PF}_f(\mathbf{w}) = a_{\mathbf{m}_1} + \langle \mathbf{m}_1, \mathbf{w} \rangle$  and  $\text{PF}_g(\mathbf{w}) = b_{\mathbf{m}_2} + \langle \mathbf{m}_2, \mathbf{w} \rangle$ . In particular, the minimum

$$\min\{a_{\mathbf{m}} + b_{\mathbf{m}'} + \langle \mathbf{m} + \mathbf{m}', \mathbf{w} \rangle : \mathbf{m}, \mathbf{m}' \in \mathbf{Z}_{\geq 0}^n\}$$

is attained exactly once, namely for  $\mathbf{m} = \mathbf{m}_1$  and  $\mathbf{m}' = \mathbf{m}_2$ , and equal to  $\text{PF}_f(\mathbf{w}) + \text{PF}_g(\mathbf{w})$ . Since for  $k \in \mathbf{Z}_{\geq 0}$  we have  $c_k \geq \min\{a_{\mathbf{m}} + b_{\mathbf{m}'} : \mathbf{m} + \mathbf{m}' = k\}$ , with equality if the minimum is attained exactly once, it follows that  $c_{\mathbf{m}_1 + \mathbf{m}_2} = a_{\mathbf{m}_1} + b_{\mathbf{m}_2}$  and that

$$\text{PF}_h(\mathbf{w}) = c_{\mathbf{m}_1 + \mathbf{m}_2} + \langle \mathbf{m}_1 + \mathbf{m}_2, \mathbf{w} \rangle = \text{PF}_f(\mathbf{w}) + \text{PF}_g(\mathbf{w}).$$

By continuity of polynomial functions, this implies that  $\text{PF}_h = \text{PF}_f + \text{PF}_g$  on all of  $\mathbf{R}^n$ .  $\square$

### 4.2.3 Initial forms

Let  $H$  be a hyperfield and  $f \in (H \rtimes \mathbf{R})[\mathbf{x}]$  and let  $\mathbf{w} \in \mathbf{R}^n$ . Consider the sub-hyperring  $H \rtimes \mathbf{R}_{\geq 0} = \nu^{-1}(\mathbf{R}_{\geq 0} \cup \{\infty\})$  analogous to the valuation subring in a valued field. By definition of polynomial functions, we have

$$\tilde{f} := t^{-\text{PF}_{f\nu}(\mathbf{w})} f(t^{w_1}x_1, \dots, t^{w_n}x_n) \in (H \rtimes \mathbf{R}_{\geq 0})[\mathbf{x}]$$

and the minimum of the valuations of the coefficients of  $\tilde{f}$  is 0. Denote

$$r: H \rtimes \mathbf{R}_{\geq 0} \rightarrow H, \quad (h, l) \mapsto \begin{cases} 0 & \text{if } l > 0, \\ h & \text{else.} \end{cases}$$

One checks that  $r$  is a morphism of hyperrings. The *initial form*  $\text{in}_{\mathbf{w}}(f)$  is defined as the image of  $\tilde{f}$  under  $r$ , that is

$$\text{in}_{\mathbf{w}}(f) = (\tilde{f})^r.$$



**Lemma 4.2.16.** *Let  $f, g \in (H \rtimes \mathbf{R})[\mathbf{x}]$ , let  $\mathbf{w} \in \mathbf{R}^n$ , and let  $h \in f \cdot g$ . Then we have*

$$\text{in}_{\mathbf{w}}(\mathbf{h}) \in \text{in}_{\mathbf{w}}(f) \cdot \text{in}_{\mathbf{w}}(g).$$

*Proof.* By Lemma 4.2.15 we have  $\text{PF}_{h^\nu}(\mathbf{w}) = \text{PF}_{f^\nu}(\mathbf{w}) + \text{PF}_{g^\nu}(\mathbf{w})$ . It follows that

$$\begin{aligned} & t^{-\text{PF}_{h^\nu}(\mathbf{w})} h(t^{w_1} x_1, \dots, t^{w_n} x_n) \\ & \in (t^{-\text{PF}_{f^\nu}(\mathbf{w})} f(t^{w_1} x_1, \dots, t^{w_n} x_n)) (t^{-\text{PF}_{g^\nu}(\mathbf{w})} g(t^{w_1} x_1, \dots, t^{w_n} x_n)). \end{aligned}$$

Applying the hyperring morphism  $H \rtimes \mathbf{R}_{\geq 0} \rightarrow H$  to both sides of “ $\in$ ” finishes the proof.  $\square$

We can then define the initial form of  $f \in K[\mathbf{x}]$  at  $\mathbf{w} \in \mathbf{R}^n$  by

$$\text{in}_{\mathbf{w}}(f) = \text{in}_{\mathbf{w}}(f^{\nu_{\text{ac}}}).$$

This recovers the definition from the literature [MS15, Chapter 2.4].

#### 4.2.4 Tropical Hypersurfaces

**Definition 4.2.17.** Let  $f \in \mathbf{T}[\mathbf{x}]$  be a tropical polynomial. Its associated *bend locus*, *zero set*, *variety* or *hypersurface* is the set  $V(f) = \{\mathbf{b} \in \mathbf{R}^n : f(\mathbf{b}) \ni \infty\}$ .

**Remark 4.2.18.** *Over a general hyperfield, one can also consider the zero set of a polynomial  $f$  as  $\{a \in H^n : f(a) \ni 0_H\}$ . For our purposes, we defined the zero set as a subset of  $\mathbf{R}^n = (\mathbf{T}^*)^n$  instead of  $\mathbf{T}^n$  as that matches the more familiar definition of a tropical hypersurface [MS15].*

*Such “equations over hyperfields” were first studied by Viro [Vir11]. For the tropical reals, Jell-Scheiderer-Yu reworded semialgebraic inequalities in terms of a polynomial containing a positive, non-negative, zero, etc. element of  $\mathbf{TR}$  [JSY22].*

For a polynomial  $f \in \mathbf{T}[\mathbf{x}]$ , the associated hypersurface,  $V(f)$ , carries a natural polyhe-

dral structure. Namely, one defines  $w, w' \in V(f)$  to be in the relative interior of the same polyhedron if and only if  $\text{in}_w(f) = \text{in}_{w'}(f)$ . The facets of this polyhedral complex consist of precisely those points  $w$  for which  $\text{in}_w(f)$  is a binomial.

This is a *weighted* polyhedral complex where, if  $\text{in}_w(f) = x^a + x^b$  is a binomial, the weight  $V(f)[\sigma]$  of the facet  $\sigma$  containing  $w$  is the integral length of  $a - b$ . The polyhedral complex on  $V(f)$ , together with the weights on the facets, is called the tropical hypersurface of  $f$ . By abuse of notation, we also denote it by  $V(f)$ .

There is also a dual complex to  $V(f)$ , which is the polyhedral complex on the Newton polytope of  $f$  whose non-empty polyhedra are the convex hull of the supports of polynomials of the form  $\text{in}_w(f)$  for  $w \in \mathbf{R}^n$ . The components of  $\mathbf{R}^n \setminus V(f)$  correspond to the vertices of the Newton subdivision, which in turn are precisely the exponents of the essential monomials of  $f$ . The facets of  $V(f)$  correspond to the edges of the Newton subdivision.

While we described  $V(f)$  in terms of  $f$  for simplicity, it only depends on the polynomial function  $\text{PF}_f$ . In fact,  $V(f)$  determines  $\text{PF}_f$  up to a linear function. As polynomial functions can be added (tropical multiplication), this induces a sum of tropical hypersurfaces as well. The sum of two tropical hypersurfaces  $V$  and  $W$  can be described explicitly without reference to the defining polynomials (or polynomial functions). Namely, the underlying set of  $V + W$  is  $V \cup W$ , and the weights are the sums of the weights of  $V$  and  $W$ , where on  $V \setminus W$  we take the weight to be 0, and similarly on  $W \setminus V$ .

### 4.3 Factoring multivariate polynomials over hyperfields

#### 4.3.1 The hyperfield multiplicity

**Definition 4.3.1.** Let  $\mathcal{F}, \mathcal{L} \subseteq H[x]$  be non-empty sets of polynomials over a hyperfield  $H$  and assume that the degree is bounded on  $\mathcal{F}$  (i.e. there exists some  $d > 0$  such that all  $f \in \mathcal{F}$  have degree at most  $d$ ). We let

$$(\mathcal{F} : \mathcal{L}) = \{g \in H[x] : g \cdot l \cap \mathcal{F} \neq \emptyset \text{ for some } l \in \mathcal{L}\}.$$

Then we define the *hyperfield multiplicity*  $\text{mult}_{\mathcal{L}}^H(\mathcal{F})$  as follows: if  $\mathcal{L}$  contains a unit, we set  $\text{mult}_{\mathcal{L}}^H(\mathcal{F}) = \infty$ . Otherwise, we define the multiplicity inductively as

$$\text{mult}_{\mathcal{L}}^H(\mathcal{F}) = \begin{cases} 0 & \text{if } (\mathcal{F} : \mathcal{L}) = \emptyset, \\ 1 + \text{mult}_{\mathcal{L}}^H((\mathcal{F} : \mathcal{L})) & \text{else.} \end{cases}$$

If  $\mathcal{L} = \{l\}$  or  $\mathcal{F} = \{f\}$  are singletons, we will use the same notation without the braces, such as  $(f : l)$  or  $\text{mult}_l^H(f)$ .

**Remark 4.3.2.** *In most prior works, the multiplicity operator is defined for one polynomial and one linear factor. The exception to this is the work of Liu, which allows for a set of linear factors (but where  $\mathcal{F}$  is still a single polynomial) [Liu20].*

**Example 4.3.3.** If  $H = \mathbf{K}$ , and  $l = 1 + \sum_{i=1}^n x_i \in \mathbf{K}[x_1, \dots, x_n]$ , then  $l \cdot \sum_{|m| \leq d-1} \mathbf{x}^m$  is the set of all polynomials over  $\mathbf{K}$  of Newton-degree  $d$ . So if  $f \in \mathbf{K}[\mathbf{x}]$  has Newton-degree  $d$ , then  $\text{mult}_l(f) = d$ .  $\diamond$

**Lemma 4.3.4.** *Let  $\mathcal{F}, \mathcal{L} \subseteq H[\mathbf{x}]$  be non-empty sets such that the degree is bounded on  $\mathcal{F}$ . Then we have*

$$\text{mult}_{\mathcal{L}}^H(\mathcal{F}) = \max\{\text{mult}_{\mathcal{L}}^H(f) : f \in \mathcal{F}\}.$$

*Proof.* It follows directly from the definition of the multiplicity that if  $\emptyset \neq \mathcal{F}' \subseteq \mathcal{F}$ , then

$$\text{mult}_{\mathcal{L}}^H(\mathcal{F}') \leq \text{mult}_{\mathcal{L}}^H(\mathcal{F}).$$

Therefore, we have

$$\text{mult}_{\mathcal{L}}^H(\mathcal{F}) \geq \max\{\text{mult}_{\mathcal{L}}^H(f) : f \in \mathcal{F}\}.$$

We show the reverse implication by induction on  $\text{mult}_{\mathcal{L}}^H(\mathcal{F})$ , the base case  $\text{mult}_{\mathcal{L}}^H(\mathcal{F}) = 0$  being trivial. If  $\text{mult}_{\mathcal{L}}^H(\mathcal{F}) > 0$ , then we have

$$\text{mult}_{\mathcal{L}}^H((\mathcal{F} : \mathcal{L})) = \max\{\text{mult}_{\mathcal{L}}^H(g) : g \in (\mathcal{F} : \mathcal{L})\}$$

by the induction hypothesis. Let  $g \in (\mathcal{F} : \mathcal{L})$  be an element where this maximum is attained and let  $f \in \mathcal{F}$  and  $l \in \mathcal{L}$  such that  $f \in g \cdot l$ . Then we have

$$\begin{aligned} \text{mult}_{\mathcal{L}}^H(f) &= \text{mult}_{\mathcal{L}}^H((f : \mathcal{L})) + 1 \geq \text{mult}_{\mathcal{L}}^H(g) + 1 \\ &= \text{mult}_{\mathcal{L}}^H((\mathcal{F} : \mathcal{L})) + 1 = \text{mult}_{\mathcal{L}}^H(\mathcal{F}). \quad \square \end{aligned}$$

**Lemma 4.3.5.** *Let  $H_1$  and  $H_2$  be hyperfields, let  $\Phi: H_1[\mathbf{x}] \rightarrow H_2[\mathbf{x}]$  be a diagonal transformation. Let  $\mathcal{L}, \mathcal{F} \subseteq H_1[\mathbf{x}]$  such that the degree is bounded on  $\mathcal{F}$ . Suppose that  $\Phi(\mathcal{F})$  does not contain the zero polynomial. Then we have*

$$\text{mult}_{\mathcal{L}}^{H_1}(\mathcal{F}) \leq \text{mult}_{\Phi(\mathcal{L})}^{H_2}(\Phi(\mathcal{F})).$$

*Proof.* Since the degree is bounded on  $\mathcal{F}$ , it is also bounded on  $\Phi(\mathcal{F})$ . Also, if  $\mathcal{L}$  contains a unit, then so does  $\Phi(\mathcal{L})$ . Therefore, we may assume that neither  $\mathcal{L}$  nor  $\Phi(\mathcal{L})$  contain a unit.

The result now follows by induction from Corollary 4.2.5 and Lemma 4.2.8.  $\square$

### 4.3.2 The boundary multiplicity

For  $i = 0, \dots, n$ , let  $\pi_i$  be the monomial transformation which substitutes  $x_i \mapsto 0$  and  $x_j \mapsto x_j$  for  $j \neq i$ . These monomial transformations are subject to Lemma 4.3.5.

**Definition 4.3.6.** Let  $\mathcal{F}, \mathcal{L} \subseteq H[x_1, \dots, x_n]$  be nonempty sets such that the degree on  $\mathcal{F}$  is bounded. Let  $\tilde{\mathcal{F}}$  and  $\tilde{\mathcal{L}}$  denote the polynomials in the variables  $x_0, \dots, x_n$  obtained by homogenizing the sets  $\mathcal{F}$  and  $\mathcal{L}$ , respectively. We define the *boundary multiplicity* of  $\mathcal{F}$  at  $\mathcal{L}$  to be

$$\partial\text{-mult}_{\mathcal{L}}^H(\mathcal{F}) = \partial\text{-mult}_{\tilde{\mathcal{L}}}^H(\tilde{\mathcal{F}}) = \min\{\text{mult}_{\pi_i(\tilde{\mathcal{L}})}^H(\pi_i(\tilde{\mathcal{F}})) : 0 \leq i \leq n\}$$

**Corollary 4.3.7.** *Let  $\mathcal{F}, \mathcal{L} \subset H[\mathbf{x}]$  be nonempty sets with bounded degree on  $\mathcal{F}$ . We have*

$$\text{mult}_{\mathcal{L}}^H(\mathcal{F}) \leq \partial\text{-mult}_{\mathcal{L}}^H(\mathcal{F}).$$

*Proof.* Since multiplicities are not affected by homogenization, this follows directly from Lemma 4.3.5 applied to the morphisms  $\pi_i$  for  $0 \leq i \leq n$ .  $\square$

**Example 4.3.8.**

- (a) If  $f \in \mathbf{K}[\mathbf{x}]$  has Newton-degree  $d$  and  $l \in \mathbf{K}[\mathbf{x}]$  is the unique polynomial of Newton-degree 1, then by Example 4.3.3 we have

$$\text{mult}_l^{\mathbf{K}}(f) = \partial\text{-mult}_l^{\mathbf{K}}(f) = d.$$

- (b) Let  $f \in \mathbf{S}[x, y, z]$  be the degree-3 polynomial given by

$$f = \begin{array}{cccc} & & & + \\ & & - & + \\ & + & + & - \\ + & + & - & + \end{array}$$

and let  $l$  be the degree-1 polynomial given by

$$l = \begin{array}{cc} + & \\ + & + \end{array}.$$

Then by the univariate Descartes' Rule of Signs [Gun22b, Example A.2], [BL21a, Theorem C], we have  $\partial\text{-mult}_l^{\mathbf{S}}(f) = 1$ . We claim that  $\text{mult}_l^{\mathbf{S}}(f) = 0$ . Indeed, if  $f \in g \cdot l$ , then it follows from the conditions on the boundary that

$$g = \begin{array}{ccc} & + & \\ & - & - \\ + & - & + \end{array}$$

But for this choice of  $g$ , the  $xy$ -coefficient of any  $h \in g \cdot l$  is necessarily negative, contradicting the fact that the  $xy$ -coefficient of  $f$  is positive.

$\diamond$

### 4.3.3 Multiplicities and initial forms

**Example 4.3.9.** Let  $f = \sum_{m \in \mathbf{Z}_{\geq 0}^n} a_m x^m \in (H \rtimes \mathbf{R})[\mathbf{x}]$  be a polynomial in  $n$ -variables and let  $\mathbf{w} \in \mathbf{R}^n$ . Moreover, let  $l = 1 + \sum_{i=1}^n t^{-w_i} x_i \in (H \rtimes \mathbf{R})[\mathbf{x}]$ . We have

$$\mathrm{in}_{\mathbf{w}}(l) = 1 + \sum_{i=1}^n x_i.$$

In the univariate case (i.e.  $n = 1$ ), we have

$$\mathrm{mult}_l(f) = \mathrm{mult}_{\mathrm{in}_{\mathbf{w}}(l)}(\mathrm{in}_{\mathbf{w}}(f))$$

by [Gun22b, Theorem A] (= Theorem 3.A). This cannot be true in higher dimensions by Lemma 4.2.15. Concretely, it fails for the polynomial

$$f = 0 + x + y + 2x^2 + 1xy + 2y^2 \in \mathbf{T}[x, y]$$

and  $\mathbf{w} = 0$ . Here, we have  $\mathrm{in}_0(f) = \mathrm{in}_0(l) = 1 + x + y$  and hence  $\mathrm{mult}_{\mathrm{in}_{\mathbf{w}}(l)}(\mathrm{in}_{\mathbf{w}}(f)) = 1$ . On the other hand,  $V(f)$  does not contain  $V(l)$ , as shown in Figure 4.3, and therefore  $\mathrm{mult}_l(f) = 0$  by Lemma 4.2.15. We observe that

$$\mathrm{mult}_l(f) \leq \mathrm{mult}_{\mathrm{in}_{\mathbf{w}}(l)}(\mathrm{in}_{\mathbf{w}}(f))$$

in this example. ◇

**Proposition 4.3.10.** *Let  $H$  be a hyperfield, let  $f \in (H \rtimes \mathbf{R})[\mathbf{x}]$ , and let  $\mathbf{w} \in \mathbf{R}^n$ . Moreover, let  $\mathcal{L}$  be a set of linear forms. Then we have*

$$\mathrm{mult}_{\mathcal{L}}(f) \leq \mathrm{mult}_{\mathrm{in}_{\mathbf{w}}(\mathcal{L})}(\mathrm{in}_{\mathbf{w}}(f)),$$

where  $\mathrm{in}_{\mathbf{w}}(\mathcal{L}) = \{\mathrm{in}_{\mathbf{w}}(l) : l \in \mathcal{L}\}$ .

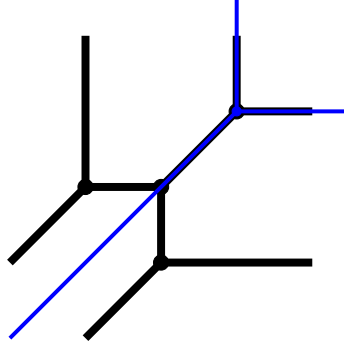

Figure 4.3: Tropical curves defined by  $0 + x + y + 2x^2 + 1xy + 2y^2$  and  $0 + x + y$ .

*Proof.* This follows from Lemma 4.2.16 and induction.  $\square$

In the case where the polynomial  $f$  is defined over a field and factors as a product of linear forms, the initial forms contain considerably more information:

**Proposition 4.3.11.** *Let  $K$  be an algebraically closed valued field with residue field  $\kappa$ , let  $f = \prod_{i=1}^d l_i \in K[\mathbf{x}]$  be a product of linear polynomials  $l_i \in K[\mathbf{x}]$ , and let  $\mathbf{w} \in \mathbf{R}^n$ . Moreover, let  $l = 0 + \sum(-w_i) \cdot x_i \in \mathbf{T}[\mathbf{x}]$ . Then we have*

$$\text{mult}_{\nu^{-1}\{l\}}^K(f) = \text{mult}_{\nu_0^{-1}\{\text{in}_{\mathbf{w}}(l)\}}^{\kappa}(\text{in}_{\mathbf{w}}(f))$$

*Proof.* After potentially scaling  $f$  and the  $l_i$ , we may assume that the constant coefficient of each  $l_i$ , if it exists, is equal to 1. Then the multiplicity  $\text{mult}_{\nu^{-1}\{l\}}^K(f)$  is equal to the number of  $1 \leq i \leq d$  such that  $l_i^{\nu} = l$ . Under the assumption on the constant coefficients,  $l_i^{\nu} = l$  is equivalent to  $\text{in}_{\mathbf{w}}(l_i)$  having support  $\Delta_n$ , which is equivalent to

$$\text{in}_{\mathbf{w}}(l_i)^{\nu_0} = 1 + \sum_{j=1}^n x_j = \text{in}_{\mathbf{w}}(l) \in \mathbf{K}[\mathbf{x}]$$

Combining this with the fact that

$$\text{in}_{\mathbf{w}}(f) = \prod_{i=1}^d \text{in}_{\mathbf{w}}(l_i)$$

(Lemma 4.2.16), concludes the proof.  $\square$

**Lemma 4.3.12.** *Let  $K$  be a valued real closed field with residue field  $\kappa$ , and let  $f = \prod_{i=1}^d l_i \in K[\mathbf{x}]$  be a product of linear polynomials  $l_i \in \overline{K}[\mathbf{x}]$  over the algebraic closure  $\overline{K} = K[\sqrt{-1}]$  of  $K$ . Furthermore, let  $\mathbf{w} \in \mathbf{R}^n$  and assume that a degree-1 polynomial  $\bar{l} \in \kappa[\mathbf{x}]$  divides  $\text{in}_{\mathbf{w}}(f)$  with multiplicity 1. Then there exists a degree-1 polynomial  $l \in K[\mathbf{x}]$  dividing  $f$  with  $\text{in}_{\mathbf{w}}(l) = \bar{l}$ .*

*Proof.* We have  $\text{in}_{\mathbf{w}}(f) = \prod_{i=1}^d \text{in}_{\mathbf{w}}(l_i)$  by Lemma 4.2.16. In particular, we may assume that after potentially renumbering and scaling by an appropriate element in  $\overline{K}^*$ , we have  $\text{in}_{\mathbf{w}}(l_1) = \bar{l}$ . It remains to show that  $l_1 \in K[\mathbf{x}]$ . Let  $\iota: \overline{K} \rightarrow \overline{K}$  denote complex conjugation. Then  $f^\iota = f$ , and therefore  $l_1^\iota$  agrees with  $l_j$  up to a constant factor for some  $1 \leq j \leq d$ . It follows that  $\text{in}_{\mathbf{w}}(l_j)$  and  $\text{in}_{\mathbf{w}}(l_1) = \bar{l}$  differ by a constant. By the assumption that  $\bar{l}$  divides  $\text{in}_{\mathbf{w}}(f)$  with multiplicity 1, we conclude that  $j = 1$ . After potentially scaling by a constant, we may thus assume that  $l_1^\iota = l_1$ , that is that  $l_1 \in K[\mathbf{x}]$ .  $\square$

**Proposition 4.3.13.** *Let  $K$  be a valued real closed field with residue field  $\kappa$ . Suppose  $f \in K[\mathbf{x}]$  factors as a product of linear forms  $f = \prod_{i=1}^d l_i$  over the algebraic closure  $\overline{K} = K[\sqrt{-1}]$  of  $K$ , and let  $\mathbf{w} \in \mathbf{R}^n$ . Moreover, let  $l = 1t^0 + \sum s_i t^{-w_i} x_i \in \mathbf{TR}[\mathbf{x}]$  for a choice of signs  $s_i \in \mathbf{S}^*$ . Assume that each factor of  $\text{in}_{\mathbf{w}}(f)$  has multiplicity 1. Then we have*

$$\text{mult}_{\nu_{\text{sgn}}^{-1}\{l\}}^K(f) = \text{mult}_{\text{sign}^{-1}\{\text{in}_{\mathbf{w}}(l)\}}^\kappa(\text{in}_{\mathbf{w}}(f))$$

*Proof.* We have

$$\text{in}_{\mathbf{w}}(f) = \prod_{i=1}^d \text{in}_{\mathbf{w}}(l_i).$$

As a linear form  $g \in K[\mathbf{x}]$  is contained in  $K_{>0} \cdot \nu_{\text{sgn}}^{-1}\{l\}$  if and only if  $\text{in}_{\mathbf{w}}(g) \in \text{sign}^{-1}\{\text{in}_{\mathbf{w}}(l)\}$ , it follows that

$$\text{mult}_{\nu_{\text{sgn}}^{-1}\{l\}}^K(f) \leq \text{mult}_{\text{sign}^{-1}\{\text{in}_{\mathbf{w}}(l)\}}^\kappa(\text{in}_{\mathbf{w}}(f)).$$



The reverse inequality follows directly from Lemma 4.3.12. □

#### 4.3.4 The geometric multiplicity

Suppose we have a hyperfield with valuation, say  $H \rtimes \mathbf{R}$ . Given a polynomial  $f$  over  $H \rtimes \mathbf{R}$ , the valuation creates a tropical hypersurface  $V(f)$ . If  $f$  has a linear factor, then we will have a linear component in this tropical hypersurface as well. Specifically, as observed in Example 4.3.9, it is a direct consequence of Lemma 4.2.15 that for any linear form  $l$  and polynomial  $f$  we have

$$V(f) = \text{mult}_l(f) \cdot V(l) + V(g)$$

for some polynomial  $g$ . This warrants the following definition.

**Definition 4.3.14.** Let  $V$  be a tropical hypersurface and let  $\mathcal{L} \subseteq (H \rtimes \mathbf{R})[\mathbf{x}]$  be a subset consisting of polynomials of degree 1 that are not monomials. Then we define the *geometric multiplicity*,  $\text{gmult}_{\mathcal{L}}^{\mathbf{K}}(V)$ , of  $V$  with respect to  $\mathcal{L}$  to be

$$\text{gmult}_{\mathcal{L}}^{\mathbf{K}}(V) = \max \sum_{i=1}^k a_i$$

with the maximum taken over all  $k$  and all  $a_i \in \mathbf{Z}_{\geq 0}$  such that

$$W + \sum_{i=1}^k a_i V(l_i) = V$$

for some tropical hypersurface  $W$  and some  $l_i \in \mathcal{L}$ . For  $f \in (H \rtimes \mathbf{R})[\mathbf{x}]$  we abbreviate  $\text{gmult}_{\mathcal{L}}^{\mathbf{K}}(V(f)) = \text{gmult}_{\mathcal{L}}^{\mathbf{K}}(f)$ .

**Example 4.3.15.**

- (a) Let  $f = 0 + x + y + 1x^3 + 1x^2y + 2y^3 \in \mathbf{T}[x, y]$ . As we see from the Newton subdivision shown in Figure 4.4, the vanishing locus  $V(f)$  is a union of 2 tropical lines, one of which centered at the origin and one at  $(-0.5, -1)$ . So if  $l = 0 + x + y$ ,

then  $\text{gmult}_l^{\mathbf{K}}(f) = 1$ . On the other hand, we claim that  $\text{mult}_l(f) = 0$ . Indeed, assume that

$$f \in l \cdot (a + bx + cy + dx^2 + exy + fy^2).$$

By looking at the coefficients of the constant term,  $x^3$ , and  $y^3$ , we see that we need to have  $a = 0$ ,  $d = 1$ , and  $f = 2$ . Because the coefficients of  $f$  at  $x^2$ ,  $y^2$ , and  $xy^2$  are infinite, we also need to have  $b = 1$ ,  $c = 2$ , and  $e = 2$ . But then the  $xy$ -coefficient of  $f$  is contained in  $2 + 3 + 3 = \{2\}$ , a contradiction.

(b) Let  $f = +0 - x + y \in \mathbf{TR}[x, y]$  and  $l = +0 + x + y$ . Then  $\text{gmult}_l^{\mathbf{K}}(f) = 1$ , but  $\text{mult}_l^{\mathbf{TR}}(f) = 0$ . ◇

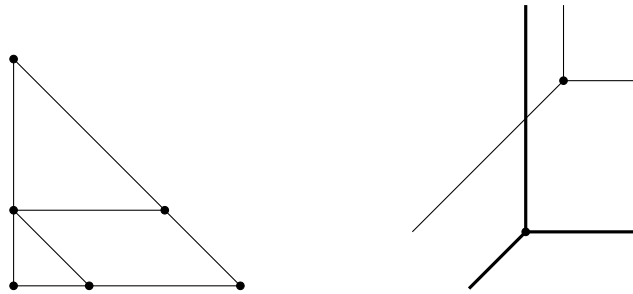

Figure 4.4: Newton subdivision of  $f = 0 + x + y + 1x^3 + 1x^2y + 2y^3$  and associated tropical curve  $V(f)$ .

While both Example 4.3.15 (a) and (b) show that the geometric multiplicity is, in general, larger than the multiplicity, the two examples are of a very different nature. Morally, in part (a) the reason for the discrepancy is that the vanishing locus of  $f$  does not “see” all monomials of  $f$  inside the Newton polytope, whereas in part (b) the reason is that the definition of geometric multiplicity of a polynomial over  $H \times \mathbf{R}$  only uses the valuation of the coefficients and does not use any information about  $H$ . To change this, we make the following definition.

**Definition 4.3.16.** Let  $H$  be a hyperfield. An  $H$ -enrichment of a tropical hypersurface  $A$  in  $\mathbf{R}^n$ , is an assignment of an element in  $H^*$  to every connected component of  $\mathbf{R}^n \setminus A$ . Equivalently, it is a map  $V \rightarrow H$ , where  $V$  is the set of vertices of the Newton subdivision

corresponding to  $A$ . In particular, every  $f \in (H \rtimes \mathbf{R})[\mathbf{x}]$  induces an  $H$ -enriched tropical hypersurface  $V(f)$ .

If  $A$  and  $B$  are two  $H$ -enriched tropical hypersurfaces, their sum  $A + B$  is defined to have the sum of the underlying tropical hypersurfaces of  $A$  and  $B$  as the underlying tropical hypersurface, and the value of a connected component  $C$  of  $\mathbf{R}^n \setminus A + B$  is the product of the values of the connected components of  $\mathbf{R}^n \setminus A$  and  $\mathbf{R}^n \setminus B$  that contain  $A$ .

**Remark 4.3.17.** *Enriched tropical hypersurfaces have also appeared in recent work of [JP22] in the context of  $\mathbf{A}^1$ -geometry. In that setting, the components of the complement of a tropical hypersurface take values in the quotient hyperfield  $k/(k^*)^2$  for some field  $k$ .*

**Definition 4.3.18.** An  $H$ -enriched tropical polynomial function on  $\mathbf{R}^n$  is a tropical polynomial function  $f: \mathbf{R}^n \rightarrow \mathbf{R}$ , together with an  $H$ -enrichment  $s$  of  $V(f)$ . The tropical product of two  $H$ -enriched tropical polynomial functions  $(f, s)$  and  $(g, s')$  is given by  $(f + g, t)$ , where  $t$  is the enrichment of  $V(f + g)$  obtained by adding the  $H$ -enriched hypersurfaces  $(V(f), s)$  and  $(V(g), s')$ . Given a polynomial  $f \in (H \rtimes \mathbf{R})[\mathbf{x}]$  in  $n$  variables, the polynomial function  $\text{PF}_{f^\nu}$  is naturally  $H$ -enriched: on each component  $C$  of  $\mathbf{R}^n \setminus V(f)$ , a unique monomial, say  $at^w x^m$ , of  $f^\nu$  is minimized, and we assign to  $C$  the value  $a \in H^*$ . We denote by  $\text{PF}_f$  the  $H$ -enriched polynomial function obtained this way.

**Lemma 4.3.19.** *Let  $f, g \in (H \rtimes \mathbf{R})[\mathbf{x}]$  and let  $h \in f \cdot g$ . Then*

$$\text{PF}_h = \text{PF}_f \odot \text{PF}_g$$

*as  $H$ -enriched tropical polynomial functions. In particular, we have*

$$V(h) = V(f) + V(g).$$

*Proof.* By Lemma 4.2.15, we only need to show that the  $H$ -enrichments on both sides coincide. Let  $C$  be a component of  $\mathbf{R}^n \setminus V(h^\nu)$  and suppose the unique monomials of  $f$

and  $g$  that are minimized on  $C$  are  $M_1 = at^{w_1}\mathbf{x}^{m_1}$  and  $M_2 = bt^{w_2}\mathbf{x}^{m_2}$ , respectively. Let  $f'$  and  $g'$  be the polynomials obtained from  $f$  and  $g$  by omitting  $M_1$  and  $M_2$ , respectively, then

$$h \in M_1M_2 + M_1g' + M_2f' + f'g'.$$

By construction, we have for any point  $\mathbf{w} \in C$  that  $\text{PF}_f(\mathbf{w}) = \text{PF}_{M_1}(\mathbf{w}) < \text{PF}_{f'}(\mathbf{w})$  and  $\text{PF}_g(\mathbf{w}) = \text{PF}_{M_2}(\mathbf{w}) < \text{PF}_{g'}(\mathbf{w})$ . Therefore,

$$\text{PF}_{M_1M_2}(\mathbf{w}) < \text{PF}_{M_1g'+M_2f'+f'g'}(\mathbf{w}),$$

from which we conclude that  $M_1M_2$  is the unique monomial of  $h$  minimized at  $\mathbf{w}$  (and hence on  $C$ ) and that the enrichment of  $h$  on  $C$  is given by  $a \cdot b$ , which is precisely the product of the enrichments of  $f$  and  $g$  there.

The statement about hypersurfaces follows immediately from the statements about polynomial functions and the fact that  $V(h^\nu) = V(f^\nu) + V(g^\nu)$ .  $\square$

We can now define an enriched version of the geometric multiplicity, completely analogous to the geometric multiplicity.

**Definition 4.3.20.** Let  $V$  be an  $H$ -enriched tropical hypersurface and let  $\mathcal{L} \subseteq (H \times \mathbf{R})[\mathbf{x}]$  be a subset consisting of linear forms. Then we define the  $H$ -enriched geometric multiplicity  $\text{gmult}_{\mathcal{L}}^H(V)$  of  $V$  with respect to  $\mathcal{L}$  to be

$$\text{gmult}_{\mathcal{L}}^H(V) = \max \sum_{i=1}^k a_i$$

with the maximum taken over all  $k$  and all  $a_i \in \mathbf{Z}_{\geq 0}$  such that

$$W + \sum_{i=1}^k a_i V(l_i) = V$$

for some  $H$ -enriched tropical hypersurface  $W$  and some  $l_i \in \mathcal{L}$ . For  $f \in (H \times \mathbf{R})[\mathbf{x}]$  we

abbreviate  $\text{gmult}_{\mathcal{L}}^H(V(f)) = \text{gmult}_{\mathcal{L}}^H(f)$ .

**Remark 4.3.21.** *Since  $\mathbf{K}^*$  only consists of one element, tropical hypersurfaces and  $\mathbf{K}$ -enriched tropical hypersurfaces are equivalent. In particular, for  $H = \mathbf{K}$  the definition of  $\text{gmult}^{\mathbf{K}}$  of Definition 4.3.20 agrees with the definition of  $\text{gmult}^{\mathbf{K}}$  from Definition 4.3.14.*

**Lemma 4.3.22.** *Let  $f \in (H \rtimes \Gamma)[\mathbf{x}]$  and let  $\mathcal{L} \subseteq (H \rtimes \Gamma)[\mathbf{x}]$  be a set of polynomials of degree 1 that are not monomials. Then we have*

$$\text{mult}_{\mathcal{L}}^{H \rtimes \Gamma}(f) \leq \text{gmult}_{\mathcal{L}}^H(f).$$

*Proof.* The assertion is a direct consequence of Lemma 4.3.19. □

**Example 4.3.23.**

(a) As noted in Remark 4.3.21, geometric multiplicity and enriched geometric multiplicity coincide over  $\mathbf{K}$ . In particular, Example 4.3.15 (a) can be seen as an example where the enriched geometric multiplicity is strictly smaller than the multiplicity. Morally speaking, any discrepancy between the geometric multiplicity and (hyperfield) multiplicity in that example is entirely due to the valuations, replacing geometric multiplicity with enriched geometric multiplicity will not reduce the discrepancy.

(b) Let  $f = 0 - x + y \in \mathbf{TR}$  and  $l = 0 + x + y$ , as in Example 4.3.15. Then  $\text{gmult}_l^{\mathbf{S}}(f) = \text{gmult}_l^{\mathbf{K}}(f) = 0$ .

◇

**Lemma 4.3.24.** *Let  $V \subseteq \mathbf{R}^n$  be an  $H$ -enriched tropical hypersurface and let  $l \in (H \rtimes \mathbf{R})[\mathbf{x}]$  be a linear form. If  $\text{gmult}_l^{\mathbf{K}}(V) > 1$ , then  $\text{gmult}_l^H(V) \geq 1$ . In particular, we either have  $\text{gmult}_l^H(V) = \text{gmult}_l^{\mathbf{K}}(V)$  or  $\text{gmult}_l^H(V) = \text{gmult}_l^{\mathbf{K}}(V) - 1$ .*

*Proof.* Let  $W$  be the unique tropical hypersurface with  $W + V(l^\nu) = V$  as tropical hypersurfaces. Because  $\text{gmult}_l^{\mathbf{K}}(V) > 1$ , we have  $V(l^\nu) \subseteq W$ , and hence  $\mathbf{R}^n \setminus V = \mathbf{R}^n \setminus W$ .

Denote by  $s$  and  $t$  the enrichments of  $V$  and  $V(l)$ , respectively. Let  $C$  be a component of  $\mathbf{R}^n \setminus W$  and let  $C'$  be the unique component of  $\mathbf{R}^n \setminus V(l^\nu)$  containing  $C$ . Then we can enrich  $W$  by assigning to  $C$  the element  $s(C) \cdot t(C')^{-1} \in H^*$ . By construction, we then have  $W + V(l^\nu) = V$  as enriched tropical hypersurfaces. This shows that  $\text{gmult}_t^H(V) \geq 1$ . The remainder of the assertion follows by induction.  $\square$

**Definition 4.3.25.** We call a polynomial  $f \in (H \rtimes \mathbf{R})[\mathbf{x}]$  *strictly convex* if  $f^\nu \in \mathbf{T}[\mathbf{x}]$  is strictly convex.

**Proposition 4.3.26.** *Let  $\Gamma$  be a subgroup of  $\mathbf{R}$ , let  $H$  be a hyperfield, let  $f \in (H \rtimes \Gamma)[\mathbf{x}]$  be a dense strictly convex polynomial, and let  $l \in (H \rtimes \Gamma)[\mathbf{x}]$  be a degree-1 polynomial that is not a monomial and such that  $\text{gmult}_t^H(f) > 0$ . Then there exists a unique polynomial  $g \in (H \rtimes \Gamma)[\mathbf{x}]$  with  $f \in g \cdot l$  and in fact  $g$  is dense, strictly convex, and we have  $\{f\} = g \cdot l$ .*

*Proof.* Let  $W$  be an enriched tropical hyperplane such that  $W + V(l) = V(f)$  and let  $g \in (H \rtimes \Gamma)[\mathbf{x}^{\pm 1}]$  with  $V(g) = W$ . Then  $V(\text{PF}_g \odot \text{PF}_l) = W + V(l) = V(\text{PF}_f)$  and therefore  $\text{PF}_g \odot \text{PF}_l$  and  $\text{PF}_f$  differ by a linear function. After multiplying  $g$  by a suitable monomial, we may thus assume that  $\text{PF}_g \odot \text{PF}_l = \text{PF}_f$ . For every  $h \in g \cdot l$ , we have  $\text{PF}_h = \text{PF}_f$  by Lemma 4.3.19. But since  $f$  is dense and strictly convex this is only possible if  $f = h$ . We conclude that  $g \cdot l = \{f\}$ .

Now let  $g' \in (H \rtimes \Gamma)[\mathbf{x}^{\pm 1}]$  with  $f \in g' \cdot l$ . We will first show that  $g'$  is strictly convex. Let  $P$  be a maximal polytope in the Newton subdivision of  $g$ . It corresponds to some vertex  $\mathbf{p}$  of  $V(g)$ . Let  $Q$  be the polytope in the Newton subdivision of  $l$ , corresponding to the stratum of  $V(l)$  containing  $\mathbf{p}$ . Then the polytope in the Newton subdivision of  $f$  corresponding to  $\mathbf{p}$  is given by the Minkowski sum  $P + Q$ . Let  $\mathbf{v}$  be a vertex of  $Q$  and let  $\mathbf{w}$  be a lattice point contained in  $P$ . Then  $\mathbf{w} + \mathbf{v}$  is a lattice point of  $P + Q$ . Because  $f$  is dense and strictly convex, this implies that  $\mathbf{w} + \mathbf{v}$  is a vertex of  $P + Q$  and hence a vertex of  $P + \mathbf{v}$ . Therefore,  $\mathbf{w}$  is a vertex of  $P$ . We conclude that every lattice point in the Newton

polytope of  $g'$  is a vertex of the Newton subdivision of  $g'$ , which implies that  $g'$  is dense and strictly convex. We can now show that  $g' = g$ . Because

$$\text{PF}_g \odot \text{PF}_l = \text{PF}_f = \text{PF}_{g'} \odot \text{PF}_l,$$

we have  $\text{PF}_g = \text{PF}_{g'}$ . But by what we just showed, both  $g$  and  $g'$  are strictly convex and hence uniquely determined by their enriched polynomial functions. We conclude that  $g = g'$ .

Finally, note that  $l$  has order 0 with respect to each of the variables  $x_i$ . Therefore, the order of  $g$  coincides with the order of  $f$  with respect to each of the variables  $x_i$ . It follows that  $g$  is a polynomial, that is  $g \in (H \rtimes \Gamma)[\mathbf{x}]$ .  $\square$

**Corollary 4.3.27.** *Let  $\Gamma$  be a subgroup of  $\mathbf{R}$ , let  $H$  be a hyperfield, and let  $f \in (H \rtimes \Gamma)[\mathbf{x}]$  be a dense strictly convex polynomial. Moreover, let  $\mathcal{L} \subseteq (H \rtimes \Gamma)[\mathbf{x}]$  be a set of degree-1 polynomials not containing a monomial. Then we have*

$$\text{gmult}_{\mathcal{L}}^H(f) = \text{mult}_{\mathcal{L}}^{H \rtimes \Gamma}(f).$$

*Proof.* By Lemma 4.3.22, we need to show that

$$\text{gmult}_{\mathcal{L}}^H(f) \leq \text{mult}_{\mathcal{L}}^{H \rtimes \Gamma}(f).$$

We do induction on  $n = \text{gmult}_{\mathcal{L}}^H(f)$ , the base case  $n = 0$  being trivial. For  $n > 0$ , there exists an  $H$ -enriched tropical hypersurface  $W$  and a polynomial  $l \in \mathcal{L}$  with  $\text{gmult}_{\mathcal{L}}^H(W) = n - 1$  and  $W + V(l) = V(f)$ . In particular  $\text{gmult}_{\mathcal{L}}^H(f) > 0$ . By Proposition 4.3.26, there exists a dense strictly convex polynomial  $g \in (H \rtimes \Gamma)[\mathbf{x}]$  with  $f \in g \cdot l$ . In particular, we have  $V(f) = V(g) + V(l)$  by Lemma 4.3.19 and hence  $V(g) = W$ . Using the induction hypothesis, we conclude that

$$\text{gmult}_{\mathcal{L}}^H(f) = 1 + \text{gmult}_{\mathcal{L}}^H(g) \leq 1 + \text{mult}_{\mathcal{L}}^{H \rtimes \Gamma}(g) \leq \text{mult}_{\mathcal{L}}^{H \rtimes \Gamma}(f). \quad \square$$

### 4.3.5 Relative hyperfield multiplicity

**Definition 4.3.28.** Let  $\varphi: H_1 \rightarrow H_2$  be a morphism of hyperfields and let  $\emptyset \neq \mathcal{F}, \mathcal{L} \subseteq H_2[\mathbf{x}]$  such that the degree is bounded on  $F$ . The *relative multiplicity of  $\mathcal{F}$  at  $\mathcal{L}$  with respect to  $\varphi$* , denoted by  $\text{mult}_{\mathcal{L}}^{\varphi}(\mathcal{F})$ , is given by

$$\text{mult}_{\mathcal{L}}^{\varphi}(\mathcal{F}) = \text{mult}_{\varphi^{-1}\mathcal{L}}^{H_1}(\varphi^{-1}\mathcal{F}).$$

**Proposition 4.3.29.** Let  $\varphi: H_1 \rightarrow H_2$  be a morphism of hyperfields and let  $\emptyset \neq \mathcal{F}, \mathcal{L} \subseteq H_2[\mathbf{x}]$  such that the degree is bounded on  $\mathcal{F}$ . Then we have

$$\text{mult}_{\mathcal{L}}^{\varphi}(\mathcal{F}) \leq \text{mult}_{\mathcal{L}}^{H_2}(\mathcal{F}).$$

*Proof.* This follows immediately from Lemma 4.3.5 applied to the morphism  $H_1[\mathbf{x}] \rightarrow H_2[\mathbf{x}]$  induced by  $\varphi$ . □

### Example 4.3.30.

- (a) Let  $K$  be a field and let  $\nu_0: K \rightarrow \mathbf{K}$  be the trivial valuation. Let  $d \in \mathbf{Z}_{>0}$  be coprime to the characteristic of  $K$ , and let  $f = 1 + x^d + y^d$  and  $l = 1 + x + y$  be elements in  $\mathbf{K}[x, y]$ . We have already seen in Example 4.3.3 that  $\text{mult}_l^{\mathbf{K}}(f) = d$ . To compute the relative multiplicity with respect to  $\nu_0$ , let  $g = a + bx^d + cy^d \in K[x, y]$  be any polynomial with  $g^{\nu_0} = f$ . Since  $a + cy^d$  has only simple roots, Eisenstein's criterion, applied with respect to any prime factor of  $a + cy^d$ , shows that  $g$  is irreducible. We conclude that

$$\text{mult}_{\nu_0^{-1}\{l\}}^K(g) = \begin{cases} 1 & \text{if } d = 1, \\ 0 & \text{else,} \end{cases}$$



and therefore

$$\text{mult}_l^{\nu_0}(f) = \begin{cases} 1 & \text{if } d = 1, \\ 0 & \text{else.} \end{cases}$$

- (b) We keep the setting of part (a), but instead take  $f = \sum_{|m| \leq d} x^m$ . If  $K$  is infinite, then for  $d$  generic linear forms  $l_1, \dots, l_d \in \nu_0^{-1}\{l\}$  we have  $(\prod_{i=1}^d l_i)^{\nu_0} = f$ , and hence  $\text{mult}_l^{\nu_0}(f) = \text{mult}_l^{\mathbf{K}}(f) = d$ . If the field  $K$  is finite, things are more complicated. For example, if  $K = \mathbf{F}_2$  and  $d = 2$ , then  $\text{mult}_l^{\nu_0}(f) = 0$ .  $\diamond$

**Example 4.3.31.** For the morphism  $\text{sign}: \mathbf{R} \rightarrow \mathbf{S}$ , the hyperfield multiplicity can be strictly larger than the relative hyperfield multiplicity, even for dense polynomials. Consider the polynomial

$$f = \begin{array}{cccc} & + & & \\ - & + & & \\ + & - & - & \\ + & - & + & + \end{array} \in \begin{array}{cc} + & + \\ + & + \end{array} \cdot \begin{array}{ccc} & + & \\ - & - & \\ + & - & + \end{array}.$$

The given factorization of  $f$  is the unique way to factor out  $l = 1 + x + y$ , so we see that  $\text{mult}_l^{\mathbf{S}}(f) = \partial\text{-mult}_l^{\mathbf{S}}(f) = 1$ . However, there exists no degree-2 polynomial  $g \in \mathbf{R}[x, y]$  such that  $(1 + x + y)g$  has the given sign pattern. Assume on the contrary that such  $g$  existed. We may assume that  $g(0, 0) = 1$ , and write  $g(x, y) = 1 - ax - by + cx^2 - dxy + ey^2$ , where  $a, b, c, d, e$  are positive reals. Then we have

$$(1 + x + y)g(x, y) = 1 + (1 - a)x + (1 - b)y + (c - a)x^2 + (-a - b - d)xy + (e - b)y^2 + cx^3 + (c - d)x^2y + (-d + e)xy^2 + ey^3.$$

This product having the signs of  $f$  is equivalent to

$$\begin{array}{ll} 1 < a & 1 > b \\ c > a & e < b \\ c < d & e > d, \end{array}$$

from which we obtain a chain

$$1 < a < c < d < e < b < 1.$$

A contradiction! ◇

**Proposition 4.3.32.** *Let  $K$  be a field,  $H$  a hyperfield,  $\Gamma \subseteq \mathbf{R}$  a totally ordered group, and let  $\varphi: K \rightarrow H \rtimes \Gamma$  be a surjective morphism of hyperfields. Moreover, let  $f \in (H \rtimes \Gamma)[\mathbf{x}]$  be a dense strictly convex polynomial, and let  $\mathcal{L} \subseteq (H \rtimes \Gamma)[\mathbf{x}]$  be a set of polynomials of Newton-degree 1. Then we have*

$$\text{mult}_{\mathcal{L}}^{\varphi}(f) = \text{mult}_{\mathcal{L}}^{H \rtimes \Gamma}(f).$$

*Proof.* By Proposition 4.3.29, we have  $\text{mult}_{\mathcal{L}}^{\varphi}(f) \leq \text{mult}_{\mathcal{L}}^{H \rtimes \Gamma}(f)$ . We show the reverse inequality by induction on  $m = \text{mult}_{\mathcal{L}}^{H \rtimes \Gamma}(f)$ . The base case  $m = 0$  is trivial, so we may assume that  $m > 0$ , in which case we have  $m = 1 + \text{mult}_{\mathcal{L}}^{H \rtimes \Gamma}((f : \mathcal{L}))$ . By Lemma 4.3.4, there exists  $g \in (f : \mathcal{L})$  with  $\text{mult}_{\mathcal{L}}^{H \rtimes \Gamma}((f : \mathcal{L})) = \text{mult}_{\mathcal{L}}^{H \rtimes \Gamma}(g)$ , and by definition of  $(f : \mathcal{L})$  we have  $f \in g \cdot l$  for some  $l \in \mathcal{L}$ . By Proposition 4.3.26, the polynomial  $g$  is dense, strictly convex, and  $g \cdot l = \{f\}$ , so by the induction hypothesis we have

$$\text{mult}_{\mathcal{L}}^{H \rtimes \Gamma}(g) = \text{mult}_{\mathcal{L}}^{\varphi}(g) = \text{mult}_{\varphi^{-1}\mathcal{L}}^K(\varphi^{-1}\{g\}).$$

Again by Lemma 4.3.4, there exists  $\tilde{g} \in \varphi^{-1}\{g\}$  with

$$\text{mult}_{\varphi^{-1}\mathcal{L}}^K(\varphi^{-1}\{g\}) = \text{mult}_{\varphi^{-1}\mathcal{L}}^K(\tilde{g}).$$

Let  $\tilde{l} \in \varphi^{-1}\{l\}$ . Then we have

$$(\tilde{g} \cdot \tilde{l})^\varphi \in g \cdot l = \{f\},$$

that is  $(\tilde{g} \cdot \tilde{l})^\varphi = f$ . It follows that

$$\text{mult}_{\mathcal{L}}^\varphi(f) = \text{mult}_{\varphi^{-1}\mathcal{L}}^K(\varphi^{-1}\{f\}) \geq \text{mult}_{\varphi^{-1}\mathcal{L}}^K(\tilde{g} \cdot \tilde{l}) \geq 1 + \text{mult}_{\varphi^{-1}\mathcal{L}}^K(\tilde{g}) = m.$$

□

#### 4.3.6 Perturbation multiplicity

One technique for analyzing the roots of a polynomial in  $\mathbf{C}[\mathbf{x}]$  is to perturb the coefficients within the field of Puiseux series  $\mathbf{C}[[t^{\mathbf{Q}}]]$  and consider a homotopy as  $t \rightarrow 0$ . By analogy, if we want to compute a multiplicity over a hyperfield  $H$ , we can consider the same multiplicity in  $H \times \mathbf{R}$  after a small perturbation. We will only consider strictly convex perturbations; in the case where the polynomial  $f \in H[\mathbf{x}]$  we start with is dense, this allows us to bound the multiplicity of  $f$  from below by  $H$ -enriched geometric multiplicities, which are much easier to compute than hyperfield multiplicities.

For this multiplicity, we work over  $\mathbf{S}$ . The sign hyperfield is special in that the inclusion  $\mathbf{S} \rightarrow \mathbf{S} \times \mathbf{R} = \mathbf{TR}$  splits canonically. That is, the angular component map  $\text{ac}: \mathbf{TR} \rightarrow \mathbf{S}$  is a morphism of hyperfields.

**Remark 4.3.33.** *A tropical extension consists of an exact sequence of groups  $1 \rightarrow H^* \rightarrow E^* \rightarrow \Gamma \rightarrow 1$  meaning  $\text{im}(H^* \rightarrow E^*) = \text{eq}(1, E^* \rightarrow \Gamma)$ . The corresponding sequence of hyperrings  $0 \rightarrow H \rightarrow E \rightarrow \mathbf{K} \times \Gamma \rightarrow 0$  is not necessarily exact because  $\text{eq}(1, E^* \rightarrow \Gamma)$  is*

only the multiplicative kernel. So despite having a section  $\Gamma \rightarrow H \rtimes \Gamma, \gamma \mapsto t^\gamma$ , we should not expect that the angular component map  $\text{ac}: H \rtimes \Gamma \rightarrow H$  is a morphism.

**Definition 4.3.34.** Let  $f \in \mathbf{S}[\mathbf{x}]$  and let  $l \in \mathbf{S}[\mathbf{x}]$  be a linear form. Let  $\mathcal{F}$  denote the subset of  $\text{ac}^{-1}\{f\}$  consisting of strictly convex polynomials in  $\mathbf{TR}[\mathbf{x}]$ . We define the *perturbation multiplicity* of  $l$  in  $f$ , denoted  $\epsilon\text{-mult}_l^{\mathbf{S}}(f)$  by

$$\epsilon\text{-mult}_l^{\mathbf{S}}(f) = \text{mult}_{\text{ac}^{-1}\{l\}}^{\mathbf{TR}}(\mathcal{F}).$$

**Corollary 4.3.35.** Let  $f \in \mathbf{S}[\mathbf{x}]$  and let  $l \in \mathbf{S}[\mathbf{x}]$  be a linear form. Then we have

$$\epsilon\text{-mult}_l^{\mathbf{S}}(f) \leq \text{mult}_l^{\mathbf{S}}(f).$$

If  $f$  is dense,  $\mathcal{F} \subset \mathbf{TR}[\mathbf{x}]$  is the set of all strictly convex polynomials in  $\text{ac}^{-1}(f)$ , and  $l$  is not a monomial, then

$$\epsilon\text{-mult}_l^{\mathbf{S}}(f) = \text{gmult}_{\text{ac}^{-1}\{l\}}^{\mathbf{S}}(\mathcal{F})$$

*Proof.* The inequality is a direct consequence of Lemma 4.3.5, the equality a direct consequence of Corollary 4.3.27. □

**Remark 4.3.36.** Given a dense polynomial  $f \in \mathbf{S}[\mathbf{x}]$  and a linear form  $l \in \mathbf{S}[\mathbf{x}]$ , the equality  $\epsilon\text{-mult}_l^{\mathbf{S}}(f) = \text{gmult}_{\text{ac}^{-1}\{l\}}^{\mathbf{S}}(\mathcal{F})$  from Corollary 4.3.35 reduces the computation of  $\epsilon\text{-mult}_l^{\mathbf{S}}(f)$  to a finite problem, that is only finitely many multiplicities  $\text{gmult}_{\text{ac}^{-1}\{l\}}^{\mathbf{S}}(\tilde{f})$  for  $\tilde{f} \in \mathcal{F}$  need to be computed. Indeed, the condition that  $V(\tilde{f}) = W + V(\tilde{l})$  for some  $\mathbf{S}$ -enriched tropical hypersurface  $W$  and some  $\tilde{l} \in \text{ac}^{-1}\{l\}$  does not depend on the exact position of the vertices of the  $\mathbf{S}$ -enriched tropical hypersurface  $V(\tilde{f})$ , but only its combinatorial type. Expressed dually,  $\text{gmult}_{\text{ac}^{-1}\{l\}}^{\mathbf{S}}(\tilde{f})$  only depends on  $l, f$ , and the Newton subdivision of  $\tilde{f}$ , for which there are only finitely many choices.

Now assume we are in two variables and we are given a strictly convex  $\tilde{f}$  in  $\text{ac}^{-1}\{f\}$ . If  $V(\tilde{f}) = W + V(\tilde{l})$  as above, then the Newton subdivision of  $f$  is a mixed subdivision

of the Newton subdivisions of  $W$  and  $V(\tilde{l})$ . Because  $\tilde{f}$  is dense and strictly convex, every lattice point of  $\text{Newt}(\tilde{f})$  appears as a vertex of the Newton subdivision of  $\tilde{f}$ . This can only happen if  $W$  and  $V(\tilde{l})$  meet transversally with intersection multiplicity 1. Therefore, every cell in the mixed subdivision of  $W$  and  $V(\tilde{l})$  either is a translate of a cell in the Newton subdivision of  $W$  or  $V(\tilde{l})$ , or a parallelogram of volume 1. Since  $V(\tilde{f}) = W + V(\tilde{l})$  needs to hold on the level of  $\mathbf{S}$ -enriched tropical hypersurfaces, the signs of  $f$  and  $l$  give additional constraints on which mixed subdivisions can appear for  $f$ . Namely, each translate of a cell of the Newton subdivision of  $W$  and  $V(\tilde{l})$  has to have the same signs as in  $W$  or  $V(\tilde{l})$  or exactly opposite signs, and each parallelogram has to be of the following form, up to translation and the action of  $\text{GL}_2(\mathbf{Z})$ :

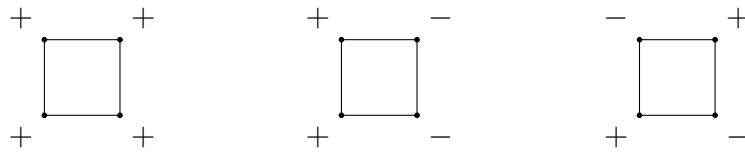

**Example 4.3.37.** With the notation as in Remark 4.3.36, let  $\tilde{f} \in \mathbf{TR}[x, y]$  be a polynomial of Newton-degree 5 with  $f^{\text{ac}}$  and its Newton subdivision as in Figure 4.5 on the top left. Then the Newton subdivision can be realized as a mixed subdivision of subdivisions of the 4-simplex and the Newton polytope of  $l = 1 + x + y$  (the 1-simplex) by declaring the triangle in dark purple in the figure as the unique unmixed cell coming from the 1-simplex, and declaring the light purple cells as the mixed cells. The dark purple unmixed cell has the same sign pattern as the Newton polytope of  $l$  and the mixed cells all have the allowed sign patterns outlined in Remark 4.3.36. We can conclude that  $V(\tilde{f}) = W + V(\tilde{l})$  for some  $\mathbf{S}$ -enriched tropical hypersurface  $W$  and some  $l \in \text{ac}^{-1}\{l\}$ . Moreover, the procedure determines the subdivision and signs of the Newton polytope of  $W$ : simply remove the cells in purple and push together the remaining cells. The result is depicted on the lower left of Figure 4.5. Note that this procedure can be repeated with the all-negative triangle and suitably chosen mixed cells, giving a total geometric multiplicity of  $\text{gmult}_{\text{ac}^{-1}\{l\}}^{\mathbf{S}}(\tilde{f}) = 2$ .

Finally, the right of Figure 4.5 shows the dual tropical picture. The given Newton

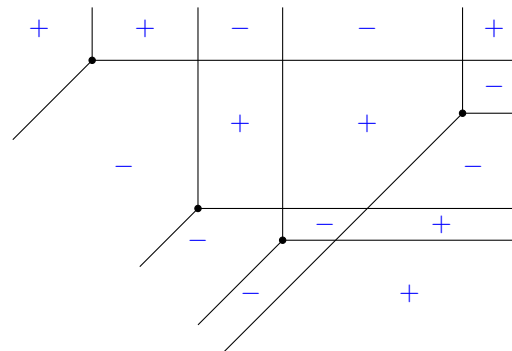
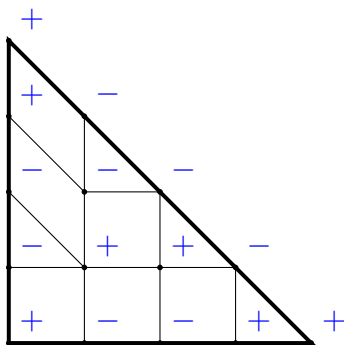
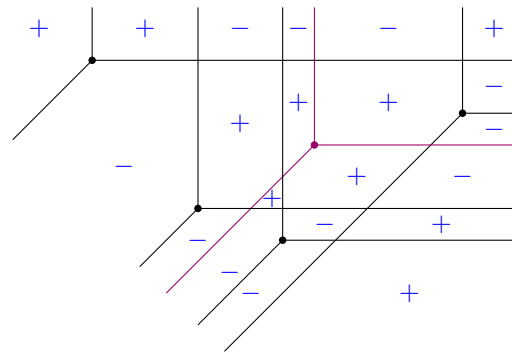
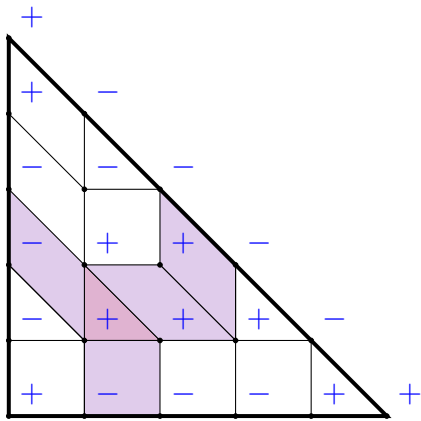

Figure 4.5: Sign compatible subdivision, quotient with induced subdivision, and associated tropical hypersurfaces.

subdivision of  $\tilde{f}$  makes  $V(\tilde{f}^\nu)$  a union of tropical lines. The tropical line  $L$  in purple on the top right corresponds to the purple cells and what we phrased in terms of subdivisions above is that there exists an  $\mathbf{S}$ -enrichment  $\tilde{L}$  of  $L$  and an  $\mathbf{S}$ -enriched tropical hypersurface  $W$  such that  $V(\tilde{f}) = W + \tilde{L}$  and  $\tilde{L} = V(\tilde{l})$  for some  $\tilde{l} \in \text{ac}^{-1}\{l\}$ . The  $\mathbf{S}$ -enriched tropical hypersurface  $W$  is depicted on the bottom right.

◇

**Example 4.3.38.** The perturbation multiplicity can also be defined over hyperfields  $H$  for which the angular component  $\text{ac}: H \times \mathbf{R} \rightarrow H$  is not a morphism. However, in these settings the inequality  $\epsilon\text{-mult}_l^H(f) \leq \text{mult}_l^H(f)$  will fail to hold in general. Consider the polynomial

$$f(x, y) = 0 + 1x + y + 1x^2 + 1xy + y^2 \in \mathbf{T}[x, y]$$

and let  $l = 0 + x + y \in \mathbf{T}[x, y]$ . Then  $\text{mult}_l^{\mathbf{T}}(f) = \text{gmult}_l^{\mathbf{T}}(f) = 0$ . Now extend from  $\mathbf{T}$  to  $\mathbf{T} \times \mathbf{R}$  (using reverse lexicographic order). We have

$$\begin{aligned} & [(0, 0) + (0, 0)x + (0, 0)y] \cdot [(0, 0) + (1, -1)x + (0, 1)y] \\ &= (0, 0) + (1, -1)x + (0, 0)y + (1, -1)x^2 + (1, -1)xy + (0, 1)y^2 \end{aligned}$$

This is a strictly convex polynomial whose (coefficient-wise) angular component is  $f$ , so  $\epsilon\text{-mult}_l^{\mathbf{T}}(f) \geq 1$ .

◇

**Proposition 4.3.39.** *Let  $f \in \mathbf{S}[\mathbf{x}]$  be dense and let  $l \in \mathbf{S}[\mathbf{x}]$  be of Newton-degree 1. Moreover, let  $K$  be a valued real closed field with value group  $\mathbf{R}$ . Then we have*

$$\epsilon\text{-mult}_l^{\mathbf{S}}(f) \leq \text{mult}_l^{\text{sign}}(f).$$

*Proof.* By Lemma 4.3.4, there exists a polynomial  $g \in \text{ac}^{-1}\{f\} \subseteq \mathbf{TR}[\mathbf{x}]$ , which is strictly convex and where  $\epsilon\text{-mult}_l^{\mathbf{S}}(f) = \text{mult}_{\text{ac}^{-1}\{l\}}^{\mathbf{TR}}(g)$ . Because  $f$  is dense,  $g$  is dense as well. By

the definition of the relative multiplicity and Proposition 4.3.32, we have

$$\text{mult}_{\text{sign}^{-1}\{l\}}^K(\nu_{\text{sgn}}^{-1}\{g\}) = \text{mult}_{\text{ac}^{-1}\{l\}}^{\nu_{\text{sgn}}}(g) = \text{mult}_{\text{ac}^{-1}\{l\}}^{\mathbf{IR}}(g).$$

As  $\nu_{\text{sgn}}^{-1}\{g\} \subseteq \text{sign}^{-1}\{f\}$ , we conclude that

$$\begin{aligned} \text{mult}_l^{\text{sign}}(f) &= \text{mult}_{\text{sign}^{-1}\{l\}}^K(\text{sign}^{-1}\{f\}) \\ &\geq \text{mult}_{\text{sign}^{-1}\{l\}}^K(\nu_{\text{sgn}}^{-1}\{g\}) = \text{mult}_{\text{ac}^{-1}\{l\}}^{\mathbf{IR}}(g). \end{aligned} \quad \square$$

**Example 4.3.40.** The perturbation multiplicity can be strictly smaller than the relative multiplicity with respect to  $\text{sign}$ , even for dense polynomials. To see this, consider the polynomial

$$f = \begin{array}{cccc} & & - & \\ - & + & & \\ + & - & - & \\ + & + & + & - \end{array} \in \begin{array}{cc} + & \\ + & + \end{array} \cdot \begin{array}{ccc} - & & \\ - & + & \\ + & + & - \end{array}$$

and let  $l = 1 + x + y$ . The given factorization of  $f$  is the unique way to factor out  $l$ , so we see that  $\text{mult}_l^{\mathbf{S}}(f) = \partial\text{-mult}_l^{\mathbf{S}}(f) = 1$ . We also have

$$f = ((1 + x + y)(1 + .5x - .3y)(1 - .33x + .01y))^{\text{sign}},$$

so that  $\text{mult}_l^{\text{sign}}(f) = 1$  as well. However, there is no signed mixed subdivision containing a positive or negative triangle, so  $\epsilon\text{-mult}_l^{\mathbf{S}}(f) = 0$ .  $\diamond$

### 4.3.7 Multiplicities over $\mathbf{S}$ in degree 2

Since multiplicities in degree 1 are trivial, we now study in detail the first interesting case of polynomials of Newton-degree 2. We work entirely over the hyperfield  $\mathbf{S}$ .

**Proposition 4.3.41.** *Let  $H$  be a hyperfield, let  $f \in H[x]$  be a polynomial of Newton-degree*



2 in  $n \geq 2$  variables and let  $l \in \mathbf{S}[x]$  be of Newton-degree 1. Then we have

$$\partial\text{-mult}_l^{\mathbf{S}}(f) = \text{mult}_l^{\mathbf{S}}(f).$$

*Proof.* To simplify notation, we homogenize both  $l$  and  $f$ , introducing a new variable  $x_0$ . After scaling the variables appropriately, we may further assume that  $l = \sum_{i=0}^n x_i$ . Let  $A$  be the support of  $f$  and write  $f = \sum_{\mathbf{a} \in A} c_{\mathbf{a}} \mathbf{x}^{\mathbf{a}}$ . Let  $h = \sum_{i=0}^n c_{2\mathbf{e}_i} x_i$ , where  $\mathbf{e}_0, \dots, \mathbf{e}_n$  denotes the standard basis of  $\mathbf{Z}^{n+1}$ . Whenever  $f \in l \cdot g$ , the square terms  $c_{2\mathbf{e}_i} x_i^2$  of  $f$  uniquely determine  $g$ . More precisely,  $f \in l \cdot g$  implies that  $g = h$ .

For  $0 \leq i \leq n$  let  $\pi_i: H[x_0, \dots, x_n] \rightarrow H[x_0, \dots, \hat{x}_i, \dots, x_n]$  be the morphism sending  $x_i$  to 0 and  $x_j$  to  $x_j$  for  $j \neq i$ . For each  $0 \leq i \leq n$ , the polynomial  $\pi_i(f)$  also has Newton-degree 2. Therefore, the same reasoning as for  $f$  applies to  $\pi_i(f)$  and  $\pi_i(f) \in \pi_i(l) \cdot g$  implies  $g = \pi_i(h)$ . Because all monomials of  $f$  only involve two variables and  $n \geq 2$ , we have  $f \in l \cdot h$  if and only if  $\pi_i(f) \in \pi_i(l) \cdot \pi_i(h)$  for all  $0 \leq i \leq n$ . By what we have observed, this implies that  $\text{mult}_l^H(f) \geq 1$  is equivalent to  $\partial\text{-mult}_l^H(f) \geq 1$ . Moreover, we have  $\text{mult}_l^H(f) = 2$  if and only if  $\text{mult}_l^H(f) \geq 1$  and  $h$  and  $l$  differ by a factor in  $H^*$ . On the other hand,  $h$  and  $l$  differ by a factor in  $H^*$  if and only if  $\pi_i(h)$  and  $\pi_i(l)$  differ by a factor in  $H^*$  for all  $0 \leq i \leq n$ , so that  $\text{mult}_l^H(f) = 2$  is equivalent to  $\partial\text{-mult}_l^H(f) = 2$ .  $\square$

**Theorem 4.3.42.** *Let  $f \in \mathbf{S}[x, y]$  be a dense polynomial of Newton-degree 2 and let  $l \in \mathbf{S}[x, y]$  be of Newton-degree 1. Then we have*

$$\epsilon\text{-mult}_l^{\mathbf{S}}(f) = \text{mult}_l^{\text{sign}}(f) = \text{mult}_l^{\mathbf{S}}(f) = \partial\text{-mult}_l^{\mathbf{S}}(f).$$

*Proof.* In light of the inequalities from Proposition 4.3.39, Proposition 4.3.29, and Corollary 4.3.7, it suffices to show that

$$\epsilon\text{-mult}_l^{\mathbf{S}}(f) = \partial\text{-mult}_l^{\mathbf{S}}(f).$$

There are 64 dense polynomials in  $\mathbf{S}[x, y]$  of Newton-degree 2, but using symmetry we can group these into 4 cases. First, consider the corners of the Newton polytope. By multiplying everything by  $-1$ , we may assume that either 2 or 3 of the corners are  $+$ . Additionally, if we view these sign arrangements as a homogeneous polynomial  $f(x, y, z) \in \mathbf{S}[x, y, z]$  then we can make use of the symmetries  $x \leftrightarrow y$ ,  $x \leftrightarrow z$  and  $y \leftrightarrow z$  to permute the corners arbitrarily. This splits the 64 polynomials into two categories:

$$\begin{array}{ccc}
 + & & + \\
 * & * & \text{and} & * & * & . \\
 + & * & + & + & * & -
 \end{array}$$

Secondly, we have the symmetries  $x \leftrightarrow -x$ ,  $y \leftrightarrow -y$  and  $z \leftrightarrow -z$  which affect the middle signs as indicated in Figure 4.6. Using these symmetries, we can assume that at least

$$\begin{array}{ccc}
 & \text{column} \times (-1) & \\
 & + \downarrow & \\
 \text{row} \times (-1) \rightarrow & * & * \\
 & + & * & - \\
 & & \swarrow & \\
 & & \text{diagonal} \times (-1) &
 \end{array}$$

Figure 4.6: Transformations  $x \leftrightarrow -x$ ,  $y \leftrightarrow -y$ ,  $z \leftrightarrow -z$ .

2 of the middle signs are  $+$ , and that leaves us with just 4 cases which we number as in Figure 4.7.

We now need to show that  $\epsilon\text{-mult}_i^{\mathbf{S}}(f) = \partial\text{-mult}_i^{\mathbf{S}}(f)$  for all Newton-degree-1 polynomials  $l \in \mathbf{S}[x, y]$ . After scaling, we may assume that  $l = 1 + sx + ty$  for some  $s, t \in \mathbf{S}^*$ . In all four cases, the constant, the  $y$ , and the  $y^2$  coefficient are positive, so  $\partial\text{-mult}_i^{\mathbf{S}}(f) = 0$  unless  $t = 1$ . In case 1, we have  $\partial\text{-mult}_i^{\mathbf{S}}(f) = 0$  if  $s = -1$  and

$$\partial\text{-mult}_i^{\mathbf{S}}(f) = 2 = \epsilon\text{-mult}_i^{\mathbf{S}}(f)$$

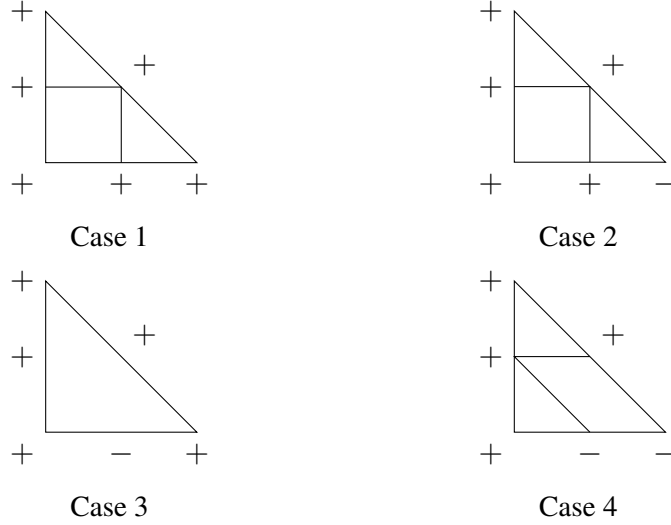

Figure 4.7: The 4 cases of Newton-degree 2 sign configurations and subdivisions.

if  $s = +1$ , where the subdivision realizing the perturbation multiplicity is depicted in Figure 4.7. In case 3, we have  $\partial\text{-mult}_l^{\mathbf{S}}(f) = 0$  for any choice of  $s$ . In cases 2 and 4, we have

$$\partial\text{-mult}_l(f) = 1 = \epsilon\text{-mult}_l(f)$$

for all  $s \in \mathbf{S}^*$ , where the subdivision realizing the perturbation multiplicity is depicted in Figure 4.7 (the same subdivision works for both choices of  $s$ ).  $\square$

**Example 4.3.43.** In dimension at least 3, there exist dense quadratic polynomials with  $\text{mult}_{1+\sum x_i}^{\text{sign}}(f) < \text{mult}_{1+\sum x_i}^{\mathbf{S}}(f)$ . To see this, consider the polynomial

$$f = 1 + x + y - z - xy - xz + yz - x^2 + y^2 - z^2 \in \mathbf{S}[x, y, z].$$

Let  $l = 1 + x + y + z$ . Then we check that

$$f \in (1 + x + y + z)(1 - x + y - z)$$

over  $\mathbf{S}$  and hence  $\text{mult}_l^{\mathbf{S}}(f) = 1$ . Now assume  $\text{mult}_l^{\text{sign}}(f) = 1$ . Then there exist polynomials  $g, h \in \mathbf{R}[x, y, z]$  with  $(g \cdot h)^{\text{sign}} = f$  and  $g^{\text{sign}} = l$ . After first scaling  $g$  such

that its constant coefficient is 1 and then rescaling each variable, we may assume that  $g = 1 + x + y + z$ . Write  $h = a + bx + cy + dz$  for  $a, b, c, d \in \mathbf{R}$ . Looking at the coefficients of  $x, xy, yz$ , and  $z$  in  $gh$  we obtain the inequalities

$$a + b > 0$$

$$b + c < 0$$

$$c + d > 0$$

$$a + d < 0,$$

which leads to the contradiction

$$a > -b > c > -d > a. \quad \diamond$$

**Theorem 4.3.44.** *Let  $f \in \mathbf{S}[x, y]$  be a (not necessarily dense) polynomial of Newton-degree 2, and let  $l \in \mathbf{S}[x, y]$  be of Newton-degree 1. Then we have*

$$\text{mult}_l^{\text{sign}}(f) = \text{mult}_l^{\mathbf{S}}(f) = \partial\text{-mult}_l^{\mathbf{S}}(f).$$

*Proof.* By Theorem 4.3.42 we only need to treat the cases where  $f$  is not dense, and by Proposition 4.3.29 and Corollary 4.3.7 it suffices to show that

$$\text{mult}_l^{\text{sign}}(f) = \partial\text{-mult}_l^{\mathbf{S}}(f)$$

If a coefficient of a middle term (e.g.  $x$ ) in  $f$  is zero, then  $\partial\text{-mult}_l^{\mathbf{S}}(f)$  is zero unless the coefficients of the adjacent corners of the Newton polytope (e.g. 1 and  $x^2$ ) have different signs. Therefore, if all three middle terms of  $f$  are zero, we have  $\partial\text{-mult}_l^{\mathbf{S}}(f) = 0$ . We may thus assume that either one or two middle terms are zero. After interchanging variables (as

+	-	-
+ +	+ +	0 +
+ 0 -	+ 0 -	+ 0 -
Case 1	Case 2	Case 3

Figure 4.8: The 3 non-dense cases needed to be checked after all reductions.

in the proof of Theorem 4.3.42), we may assume that either only the  $x$ -coefficient is zero or the  $x$ - and  $y$ -coefficient are both zero. After scaling  $f$  by a unit, we may assume that the constant coefficient is 1, in which case we may assume that the  $x^2$ -coefficient is  $-1$ . If the  $y$ -coefficient is also zero, we may also assume that the  $y^2$ -coefficient is  $-1$ . Using the transformations  $x \leftrightarrow -x$  and  $y \leftrightarrow -y$  we may assume that the non-zero middle terms have coefficient 1. This leaves us with three cases for  $f$ , as depicted in Figure 4.8. After rescaling  $l$ , we may assume that the constant coefficient of  $l$  is 1.

In case 1, we have  $\partial\text{-mult}_l^{\mathbf{S}}(f) = 0$  unless  $l = 1 \pm x + y$ , in which case  $\partial\text{-mult}_l^{\mathbf{S}}(f) = 1$ . We also have

$$f = ((1 + x + y)(1 - x + 2y))^{\text{sign}}.$$

This shows that  $\epsilon\text{-mult}_l^{\mathbf{S}}(f) = 1$  for either choice of  $l$ .

In case 2, we have  $\partial\text{-mult}_l^{\mathbf{S}}(f) = 0$  unless  $l = 1 \pm x \mp y$ , in which case  $\partial\text{-mult}_l^{\mathbf{S}}(f) = 1$ . We also have

$$f = ((1 + x - y)(1 - x + 2y))^{\text{sign}}.$$

This shows that  $\epsilon\text{-mult}_l^{\mathbf{S}}(f) = 1$  for either choice of  $l$ .

In case 3, we have  $\partial\text{-mult}_l^{\mathbf{S}}(f) = 0$  unless  $l = 1 \pm x \mp y$ , in which case  $\partial\text{-mult}_l^{\mathbf{S}}(f) = 1$ . We also have

$$f = ((1 + x - y)(1 - x + y))^{\text{sign}}.$$

This shows that  $\epsilon\text{-mult}_l^{\mathbf{S}}(f) = 1$  for either choice of  $l$ . □

**Example 4.3.45.** If  $f \in \mathbf{S}[x, y]$  is quadratic but not dense, and  $l \in \mathbf{S}[x, y]$  has degree 1, it is

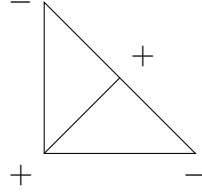

Figure 4.9: The only Newton subdivision including the support of  $1 - x^2 + xy - y^2$  as vertices.

possible that  $\epsilon\text{-mult}_l^{\mathbf{S}}(f) < \text{mult}_l^{\mathbf{S}}(f)$ . For example, consider the polynomial

$$f(x, y) = 1 - x^2 + xy - y^2 \in \mathbf{S}[x, y]$$

and let

$$l(x, y) = 1 + x - y.$$

Then we have  $\text{mult}_l^{\mathbf{S}}(f) = \partial\text{-mult}_l^{\mathbf{S}}(f) = 1$ . On the other hand, the only subdivision of the Newton polytope of  $f$  that appears as the Newton subdivision of a strictly convex polynomial in  $\text{ac}^{-1}\{l\}$  is depicted in Figure 4.9. Since the tropical hypersurface associated to any polynomial  $h \in \mathbf{TR}[x, y]$  with that Newton subdivision can never contain a tropical line, we have  $\text{gmult}_{\text{ac}^{-1}\{l\}}^{\mathbf{K}}(h) = 0$  and hence  $\text{mult}_{\text{ac}^{-1}\{l\}}^{\mathbf{TR}}(h) = 0$  by Lemma 4.3.22. In particular, we have

$$\epsilon\text{-mult}_l^{\mathbf{S}}(f) = 0 < 1 = \text{mult}_l^{\mathbf{S}}(f). \quad \diamond$$

#### 4.4 Systems of equations over hyperfields

Let  $K$  be a field with a morphism  $\varphi: K \rightarrow H$  to a hyperfield  $H$ , let  $f_1, \dots, f_n \in H[x_1, \dots, x_n]$ , and let  $\mathbf{h} \in (H^*)^n$ . In this section, we study the number

$$N_{\mathbf{h}}^{\varphi}(f_1, \dots, f_n) = \max \left\{ \left| \bigcap V(g_i) \cap \varphi^{-1}\{\mathbf{h}\} \right| : g_i = f_i, \left| \bigcap V(g_i) \right| < \infty \right\}.$$

In the case where  $H = \mathbf{S}$  (resp.  $H = \mathbf{T}$ ), this is the maximum number of solutions with given signs (resp. given valuations) that a system of equations with given supports and signs (resp. valuations) can have, provided it has finitely many solutions. Our technique to bound this number is via sparse resultants, which translate the problem of finding solutions to a system of equations into the problem of finding linear factors of a single multivariate polynomial.

#### 4.4.1 Sparse resultants

Let  $A_0, \dots, A_n$  be subsets of  $\mathbf{Z}_{\geq 0}^n$ . For each  $0 \leq i \leq n$  and  $\mathbf{a} \in A_i$  introduce a variable  $c_{i,\mathbf{a}}$ . Then the (sparse mixed) resultant  $R = R_{A_0, \dots, A_n}$  of  $A_0, \dots, A_n$  is the unique (up to scaling) irreducible integer polynomial in the variables  $c_{i,\mathbf{a}}$ , which vanishes precisely when the intersection

$$\bigcap_{i=0}^n V \left( \sum_{\mathbf{a} \in A_i} c_{i,\mathbf{a}} \mathbf{x}^{\mathbf{a}} \right) \cap (K^*)^n \quad (4.2)$$

is nonempty for some (and hence any) algebraically closed field  $K$  of characteristic 0. We expect the intersection to be nonempty on a codimension 1 set because there is one more equation than variables  $(x_1, \dots, x_n)$ . Only if the codimension is indeed 1 the resultant is well-defined; otherwise one sets  $R = 1$ . For more on resultants, we refer the reader to the book of Gelfand-Kapranov-Zelevinsky [GKZ94]. The resultants we use here are the mixed  $(A_0, \dots, A_n)$ -resultants covered in Chapter 8 of their book.

Given  $n + 1$  polynomials in  $n$ -variables, say  $g_i = \sum_{\mathbf{a} \in A_i} d_{i,\mathbf{a}} \mathbf{x}^{\mathbf{a}} \in H[\mathbf{x}]$  for  $0 \leq i \leq n$  over some hyperfield  $H$ , we denote by  $R_{g_0, \dots, g_n}$  the set (we get a set because hyperaddition is multivalued) of polynomials obtained by substituting  $d_{i,\mathbf{a}}$  for  $c_{i,\mathbf{a}}$  in  $R_{A_0, \dots, A_n}$ . If only  $n$  polynomials in  $n$  variables are given, say the polynomials  $g_1, \dots, g_n$  with the expressions as before, we introduce new variables  $y_1, \dots, y_n$  and set

$$R_{g_1, \dots, g_n} = R_{1 + \sum y_i x_i, g_1, \dots, g_n} \subseteq H[\mathbf{y}],$$

substituting  $y_i$  for the variables  $c_{0,e_i}$  corresponding to

$$A_0 = \{0\} \cup \{e_i : 1 \leq i \leq n\},$$

where  $e_i$  denotes the  $i$ -th standard basis vector in  $\mathbf{Z}_{\geq 0}^n$ .

The fact that resultants translate the problem of finding solutions to systems of equations to the problem of finding linear factors of a polynomial already mentioned above, is made precise in the following lemma.

**Lemma 4.4.1.** *Let  $K$  be a field of characteristic 0 and let  $\varphi: K \rightarrow H$  be a morphism of hyperfields. Moreover, let  $\mathbf{h} \in (H^*)^n$ , let  $l = 1 + \sum_{i=1}^n h_i x_i \in H[\mathbf{x}]$ , and let  $g_1, \dots, g_n \in K[\mathbf{x}]$  generic with respect to their support and such that  $R = R_{g_1, \dots, g_n}$  is not constant. Then we have*

$$\left| \bigcap_{i=1}^n V(g_i) \cap \varphi^{-1}\{\mathbf{h}\} \right| = \text{mult}_{\varphi^{-1}\{l\}}^K(R).$$

*Proof.* Because the coefficients of the  $g_i$  are generic with respect to their supports, the intersection

$$\bigcap_{i=1}^n V(g_i)$$

is transverse and consists of  $D := \deg(R)$  many distinct points

$$p_j = (p_{j1}, \dots, p_{jn}) \in (\overline{K}^*)^n, \quad 1 \leq j \leq D.$$

Then the intersection

$$\bigcap_{i=1}^n V(g_i) \cap V\left(1 + \sum_{i=1}^n y_i x_i\right)$$

is nonempty if and only if

$$1 + \sum_{i=1}^n p_{ji} y_i = 0$$



for some  $1 \leq j \leq D$ , which happens, by definition of the resultant, if and only if

$$R(y_1, \dots, y_n) = 0.$$

Because  $D$  is the degree of  $R$ , it follows that  $R$  differs from

$$\prod_{j=1}^D \left( 1 + \sum_{i=1}^n p_{ji} y_i \right)$$

by a unit. The assertion now follows from the observation that  $\varphi(p_j) = \mathbf{h}$  if and only if

$$\left( 1 + \sum_{i=1}^n p_{ji} y_i \right)^\varphi = l. \quad \square$$

An important observation in the proof of the preceding lemma is that a resultant  $R_{g_1, \dots, g_n}$  is (up to a unit), the product of the linear forms  $1 + \sum p_{ji} y_i$  corresponding to the common roots  $p_j$  of the system

$$g_1(\mathbf{x}) = \dots = g_n(\mathbf{x}) = 0$$

in the algebraic closure of the ground field. Let us illustrate this with an example.

**Example 4.4.2.** Take the line  $f(x, y) = 3x + 4y - 5$  and intersect it with the circle  $g(x, y) = x^2 + y^2 - 1$ . These two polynomials have one intersection point  $[3 : 4 : 5] \in \mathbf{P}^2$ , with multiplicity 2. The resultant of  $f$  and  $g$  in the variables  $u, v$  is therefore proportional to  $(3u + 4v + 5)^2$ .

Let us show an example computation using the Singular computer algebra system [Sing].

```
system("random", 12341234);
// other seeds lead to different monomial factors
ring R = 0, (u, v), dp;
ring S = R, (x, y), dp;
ideal I = 3x + 4y - 5, x2 + y2 - 1, 1 + ux + vy;
```

```

string s = string(det(mpresmat(I, 0)));
    // use a string to get this polynomial from S to R
    // s = (9u2+24uv+30u+16v2+40v+25)
setring R;
execute("poly p = " + s);
factorize(p);
    // Output (factors and multiplicities)
    // [1]:
    //   _[1]=1
    //   _[2]=3u+4v+5
    // [2]:
    //   1, 2

```

◇

#### 4.4.2 Tropically transverse intersections

We will now study the cases where  $H = \mathbf{T}$  or  $H = \mathbf{TR}$ , where  $\varphi: K \rightarrow H$  is either a valuation  $\nu$  or a signed valuation  $\nu_{\text{sgn}}$ , and where the intersection

$$\bigcap_{i=1}^n V(f_i^\nu)$$

in  $\mathbf{R}^n$  is transverse. Recall that this means that  $\bigcap_{i=1}^n V(f_i^\nu)$  is finite and every  $\mathbf{h} \in \bigcap_{i=1}^n V(f_i^\nu)$  is contained in the relative interior of a maximal cell of  $V(f_i^\nu)$  for all  $1 \leq i \leq n$ .

For every choice of  $g_i \in \varphi^{-1}\{f_i\}$  and  $\mathbf{h} \in \bigcap_{i=1}^n V(g_i) \cap (K^*)^n$  we then have  $\varphi(\mathbf{h}) \subseteq \bigcap V(f_i^\nu)$ . Therefore, we have

$$N_{\mathbf{h}}^\varphi(f_1, \dots, f_n) = 0$$

for all  $\mathbf{h} \notin \bigcap_{i=1}^n V(f_i^\nu)$ .

Now suppose  $\mathbf{h} \in \bigcap_{i=1}^n V(f_i^\nu)$ . Then for every  $1 \leq i \leq n$ , the initial form  $\text{in}_{\mathbf{h}}(f_i)$  is a binomial, say  $f_i = a_i \mathbf{x}^{s_i} - b_i \mathbf{x}^{t_i}$ . We define the *intersection multiplicity*  $m^{\mathbf{K}}(\mathbf{h}; f_1^\nu \cdots f_n^\nu)$

as

$$m^{\mathbf{K}}(\mathbf{h}; f_1^\nu \cdots f_n^\nu) = \left| \begin{pmatrix} \frac{\mathbf{s}_1 - \mathbf{t}_1}{\phantom{0}} \\ \vdots \\ \frac{\mathbf{s}_n - \mathbf{t}_n}{\phantom{0}} \end{pmatrix} \right|.$$

**Lemma 4.4.3** ([HS95, Lemma 3.2]). *Let  $\mathbf{h} \in \bigcap_{i=1}^n V(f_i^\nu)$  and for  $1 \leq i \leq n$  let  $g_i$  be polynomials with  $g_i^{\nu_0} = \text{in}_{\mathbf{h}}(f_i)^{\nu_0}$  over an algebraically closed field of characteristic 0. Then  $\bigcap_{i=1}^n V(g_i)$  contains precisely  $m^{\mathbf{K}}(\mathbf{h}; f_1 \cdots f_n)$  many distinct points.*

Now suppose that  $f_i \in \mathbf{TR}[x]$ , and still assume that  $V(f_1^\nu), \dots, V(f_n^\nu)$  intersect transversally. Let  $\mathbf{h} \in \nu^{-1} \bigcap_{i=1}^n V(f_i^\nu) \subseteq (\mathbf{TR}^*)^n$ . Then  $\text{in}_{\nu(\mathbf{h})}(f_i)$  is a binomial for all  $1 \leq i \leq n$ . Following [IR96], we say that  $\mathbf{h}$  is *alternating* if the two coefficients of the binomial  $\text{in}_{\nu(\mathbf{h})}(f_i)$  have opposite signs for all  $1 \leq i \leq n$ . If  $\text{ac}(\mathbf{h}) = (1, \dots, 1)$ , we define the signed multiplicity  $m^{\mathbf{S}}(\mathbf{h}; f_1 \cdots f_n)$  by

$$m^{\mathbf{S}}(\mathbf{h}; f_1 \cdots f_n) = \begin{cases} 1 & \text{if } \mathbf{h} \in \bigcap_{i=1}^n V(f_i^\nu) \text{ and } \mathbf{h} \text{ is alternating,} \\ 0 & \text{else.} \end{cases}$$

For general  $\mathbf{h}$ , let  $|\mathbf{h}| = (\text{ac}(h_1)h_1, \dots, \text{ac}(h_n)h_n)$  and for  $1 \leq i \leq n$  denote

$$f_i^{\mathbf{h}}(x_1, \dots, x_n) = f_i(\text{ac}(h_1)x_1, \dots, \text{ac}(h_n)x_n),$$

where we identify  $\mathbf{S}^*$  with  $\nu^{-1}\{0\} = \{\pm t^0\} \subseteq \mathbf{TR}$ . The signed multiplicity is then given by

$$m^{\mathbf{S}}(\mathbf{h}; f_1 \cdots f_n) = m^{\mathbf{S}}(|\mathbf{h}|; f_1^{\mathbf{h}} \cdots f_n^{\mathbf{h}}).$$

**Lemma 4.4.4** ([IR96, Lemma 2]). *Let  $K$  be a real closed field. Suppose we have binomials  $g_1, \dots, g_n \in K[x]$  such that the affine span of all the Newton polytopes of the  $g_i$  is  $\mathbf{R}^n$ . If for some  $1 \leq i \leq n$ , the coefficients of the two monomials of  $g_i$  have the same sign, then the*

intersection

$$\bigcap_{i=1}^n V(g_i) \cap (K_{>0})^n$$

is empty. Otherwise, it is a singleton.

In particular, suppose  $f_1, \dots, f_n \in \mathbb{R}[\mathbf{x}]$  and  $\mathbf{h} \in (\mathbb{R}^*)^n$  are chosen such that  $V(f_1^\nu), \dots, V(f_n^\nu)$  intersect transversally at  $\nu(\mathbf{h})$ . If  $g_i \in \text{sign}^{-1}\{\text{in}_{\nu(\mathbf{h})}(f_i)\}$ , then we have

$$\left| \bigcap_{i=1}^n V(g_i) \cap \text{sign}^{-1}\{\text{ac}(\mathbf{h})\} \right| = m^{\mathbf{S}}(\mathbf{h}; f_1 \cdots f_n).$$

*Proof.* The statement about the positive common roots of the  $g_i$  is proven in [IR96, Lemma 2]. The “in particular” statement follows directly from that in the case where  $\text{ac}(\mathbf{h}) = (1, \dots, 1)$ . The general case is reduced to that case by the coordinate change  $x_i \mapsto \text{ac}(h_i)x_i$ . □

We have the following relationship between the initial form of a resultant and the resultant of initial forms.

**Proposition 4.4.5.** *Let  $(K, \nu)$  be a valued field of characteristic 0, equipped with a splitting of the valuation, and let  $g_i \in K[\mathbf{x}]$  for  $1 \leq i \leq n$ . Assume that  $V(g_1^\nu), \dots, V(g_n^\nu)$  intersect transversally at  $\mathbf{h} \in \mathbb{R}^n$ . Then  $\text{in}_{-\mathbf{h}} R_{g_1, \dots, g_n}$  and  $R_{\text{in}_{\mathbf{h}}(g_1), \dots, \text{in}_{\mathbf{h}}(g_n)}$  differ by a polynomial  $q$  with*

$$\text{mult}_{\nu_0^{-1}\{1 + \sum_{j=1}^n x_j\}}(q) = 0.$$

*Proof.* For  $1 \leq i \leq n$  denote the support of  $g_i$  by  $A_i$  and let

$$A_0 = \{0\} \cup \{\mathbf{e}_i : 1 \leq i \leq n\},$$

where  $\mathbf{e}_i$  denotes the  $i$ -th standard basis vector. Moreover, let  $R = R_{A_0, \dots, A_n}$  be the resultant of the supports, which is a polynomial in coefficients  $c_{i, \mathbf{a}}$ , where  $0 \leq i \leq n$  and  $\mathbf{a} \in A_i$ . We defined  $R_{g_1, \dots, g_n}$  as a polynomial in variables  $y_1, \dots, y_n$ , but in this proof we will substitute

$c_{0,e_i}$  for  $y_i$  and view  $R_{g_1,\dots,g_n}$  as a polynomial in the variables  $c_{0,e_1}, \dots, c_{0,e_n}$ . Then  $R_{g_1,\dots,g_n}$  is obtained by plugging 1 for  $c_{0,0}$  and  $d_{i,\mathbf{a}}$  for  $c_{i,\mathbf{a}}$  for  $i > 0$  and  $\mathbf{a} \in A_i$  into  $R$ . We note that  $R$  is homogeneous in the coefficients  $c_{0,0}, c_{0,e_1}, \dots, c_{0,e_n}$ , so plugging in 1 for  $c_{0,0}$  amounts to dehomogenizing. Therefore,  $\text{in}_{(0,-\mathbf{h})}(R_{g_1,\dots,g_n})$  is equal to the polynomial we obtain by plugging in 1 for  $c_{0,0}$  into the initial form

$$\text{in}_{(0,-\mathbf{h})}R((c_{0,\mathbf{a}})_{\mathbf{a} \in A_0}, (d_{i,\mathbf{a}})_{i>0, \mathbf{a} \in A_i}),$$

where the additional 0 in  $(0, \mathbf{h})$  means that we give  $c_{0,0}$  weight zero. Let

$$\mathbf{w} = (0, -\mathbf{h}, (\nu(d_{i,\mathbf{a}}))_{i>0, \mathbf{a} \in A_i}).$$

We view  $\mathbf{w}$  as a weight on  $\mathbf{R}^{\sqcup_{i=0}^n A_i}$ . If for a monomial  $M$  of  $R$ , we denote  $M' = M((c_{0,\mathbf{a}})_{\mathbf{a} \in A_0}, (d_{i,\mathbf{a}})_{i>0, \mathbf{a} \in A_i})$ , then the  $\mathbf{w}$ -weight of  $M$  with respect to the trivial valuation  $\nu_0$  equals the  $(0, -\mathbf{h})$ -weight of  $M'$  with respect to  $\nu$  (note that  $R$  has integer coefficients). It follows that if

$$(\text{in}_{\mathbf{w}}^0(R))((c_{0,\mathbf{a}})_{\mathbf{a} \in A_0}, (\text{ac}(d_{i,\mathbf{a}}))_{i>0, \mathbf{a} \in A_i}) \neq 0,$$

where the superscript 0 in  $\text{in}^0$  indicates that we take the initial form with respect to the trivial valuation, then we have

$$\begin{aligned} & \text{in}_{(0,-\mathbf{h})}(R((c_{0,\mathbf{a}})_{\mathbf{a} \in A_0}, (d_{i,\mathbf{a}})_{i>0, \mathbf{a} \in A_i})) \\ &= (\text{in}_{\mathbf{w}}^0(R))((c_{0,\mathbf{a}})_{\mathbf{a} \in A_0}, (\text{ac}(d_{i,\mathbf{a}}))_{i>0, \mathbf{a} \in A_i}). \end{aligned}$$

To finish the proof, we compute  $(\text{in}_{\mathbf{w}}^0(R))((c_{0,\mathbf{a}})_{\mathbf{a} \in A_0}, (\text{ac}(d_{i,\mathbf{a}}))_{i>0, \mathbf{a} \in A_i})$  and, in particular, show that it is non-zero. To this end, let  $g_0 = 1 + \sum_{i=1}^n c_{0,e_i} x_i$ , and let  $\Delta$  be the polyhedral complex in  $\mathbf{R}^n$ , the relative interior of whose faces are precisely the equivalence classes of the relation

$$\mathbf{w}_1 \sim \mathbf{w}_2 \iff \text{in}_{\mathbf{w}_1}(g_i) = \text{in}_{\mathbf{w}_2}(g_i) \text{ for all } 0 \leq i \leq n.$$

Here, we give weight  $-h_i$  to the coefficient  $c_{0,i}$  of  $x_i$  in  $g_0$ . Note that  $\Delta$  coincides with the intersection of the  $n + 1$  complexes on  $\mathbf{R}^n$  induced by the tropical hypersurfaces  $V(g'_i)$ . By [Stu94a, Theorem 4.1], we have

$$(\text{in}_{\mathbf{w}}^0(R))((c_{0,\mathbf{a}})_{\mathbf{a} \in A_0}, (\text{ac}(d_{i,\mathbf{a}}))_{i>0, \mathbf{a} \in A_i}) = \pm \prod_{\mathbf{v}} R_{\mathbf{v}}^{d_{\mathbf{v}}},$$

where the product runs over all vertices  $\mathbf{v}$  of  $\Delta$ , and where

$$R_{\mathbf{v}} = R_{\text{in}_{\mathbf{v}}(g_0), \text{in}_{\mathbf{v}}(g_1), \dots, \text{in}_{\mathbf{v}}(g_n)}$$

and the  $d_{\mathbf{v}}$  are positive integers that can be computed explicitly in terms of the supports of the  $\text{in}_{\mathbf{v}}(g_i)$ .

The resultant  $R_{\mathbf{v}}$  is a monomial if at least one of the  $\text{in}_{\mathbf{v}}(g_i)$  is a monomial. Therefore, the set of vertices  $\mathbf{v}$  for which  $R_{\mathbf{v}}$  is not a monomial is contained in the set  $S$  defined by  $S = \bigcap_{i=0}^n V(g'_i)$ . For each  $\mathbf{v} \in S$  the polynomials  $\text{in}_{\mathbf{v}}(g_i)$  for  $1 \leq i \leq n$  are binomials that intersect in finitely many points, by Lemma 4.4.3, no matter how we vary their coefficients. Therefore,  $R_{\mathbf{v}} \neq 0$ . Moreover, for  $\mathbf{h} \neq \mathbf{v} \in S$  the initial form  $\text{in}_{\mathbf{v}}(g_0)$  has support strictly smaller than the support of  $g_0$ . As  $R_{\mathbf{v}}$  is a product of polynomials with the same support as  $\text{in}_{\mathbf{v}}(g_0)$ , this implies that

$$\text{mult}_{\nu_0^{-1}\{1+\sum_{j=1}^n x_j\}}(R_{\mathbf{v}}) = 0.$$

Finally, according to [Stu94a, Theorem 4.1] we have  $d_{\mathbf{h}} = 1$  because  $\text{in}_{\mathbf{h}}(g_0)$  and  $g_0$  have the same support and the support of  $g_0$  spans  $\mathbf{Z}^n$ .  $\square$

**Theorem 4.4.6.** *Let  $K$  be an algebraically closed valued field or a real closed valued field with compatible valuation, with residue field  $\kappa$ . Let  $H = \kappa/\kappa^2$  (either  $\mathbf{K}$  or  $\mathbf{S}$ ). Let  $\bar{\varphi}: \kappa \rightarrow H$  denote the quotient morphism, and let  $\varphi: K \rightarrow H \times \mathbf{R}$  denote the composite  $K \xrightarrow{\nu_{\text{ac}}} \kappa \times \mathbf{R} \xrightarrow{\varphi \times \mathbf{R}} H \times \mathbf{R}$ . Furthermore, let  $f_1, \dots, f_n \in (H \times \mathbf{R})[\mathbf{x}]$  be such that*

$V(f_1^\nu), \dots, V(f_n^\nu)$  intersect transversally, and let  $\mathbf{h} \in ((H \rtimes \mathbf{R})^*)^n$ . Then we have

$$N_{\mathbf{h}}^\varphi(f_1, \dots, f_n) = m^H(\mathbf{h}; f_1 \cdots f_n).$$

In fact, for every generic choice of  $g_i \in \varphi^{-1}\{f_i\}$  for  $1 \leq i \leq n$  we have

$$\left| \bigcap_{i=1}^n V(g_i) \cap \varphi^{-1}\{\mathbf{h}\} \right| = m^H(\mathbf{h}; f_1 \cdots f_n).$$

**Remark 4.4.7.** If  $K$  is algebraically closed, then  $H \rtimes \mathbf{R} = \mathbf{T}$  and  $\varphi = \nu$ , and if  $\mathbf{K}$  is real closed, then  $H \rtimes \mathbf{R} = \mathbf{TR}$  and  $\varphi = \nu_{\text{sgn}}$ .

*Proof.* For  $1 \leq i \leq n$  let  $g_i \in \varphi^{-1}\{f_i\}$ , let  $R = R_{g_1, \dots, g_n}$ , and let  $l = 1 + \sum_{i=1}^n h_i x_i \in \mathbf{TR}[x]$ . By Lemma 4.4.1, we have

$$\left| \bigcap_{i=1}^n V(g_i) \cap \varphi^{-1}\{\mathbf{h}\} \right| = \text{mult}_{\varphi^{-1}\{l\}}^K(R).$$

By Proposition 4.3.11 in the algebraically closed case and Lemma 4.4.3 and Proposition 4.3.13 in the real closed case, we have

$$\text{mult}_{\varphi^{-1}\{l\}}^K(R) = \text{mult}_{\overline{\varphi}^{-1}\{\text{in}_{-\nu}(\mathbf{h})(l)\}}^\kappa(\text{in}_{-\nu}(\mathbf{h})(R)).$$

By Proposition 4.4.5, we have

$$\begin{aligned} & \text{mult}_{\overline{\varphi}^{-1}\{\text{in}_{-\nu}(\mathbf{h})(l)\}}^\kappa(\text{in}_{-\nu}(\mathbf{h})(R)) \\ &= \text{mult}_{\overline{\varphi}^{-1}\{\text{in}_{-\nu}(\mathbf{h})(l)\}}^\kappa(R_{\text{in}_{\nu}(\mathbf{h})(g_1), \dots, \text{in}_{\nu}(\mathbf{h})(g_n)}), \end{aligned}$$

which, again by Lemma 4.4.1, is equal to

$$\left| \bigcap_{i=1}^n V(\text{in}_{\nu}(\mathbf{h})(g_i)) \cap \overline{\varphi}^{-1}\{\text{ac}(\mathbf{h})\} \right|.$$

By Proposition 4.3.11 in the algebraically closed case and Proposition 4.3.13 in the real closed case, we have

$$\left| \bigcap_{i=1}^n V(\text{in}_{\mathbf{h}}(g_i) \cap \overline{\varphi}^{-1}\{\text{ac}(\mathbf{h})\}) \right| = m^H(\mathbf{h}; f_1^\nu \cdots f_n^\nu). \quad \square$$

Using some model theory, we can apply our results about the numbers  $N_{\mathbf{h}}^{\nu_{\text{sgn}}}(f_1, \dots, f_n)$  for  $f_i \in \mathbf{TR}[\mathbf{x}]$ , to obtain the following result about the analogous numbers for  $f_i \in \mathbf{S}[\mathbf{x}]$ . As further explained below after Definition 4.4.9, we reprove the main Corollary to [IR96, Theorem 2].

**Corollary 4.4.8.** *Let  $K$  be a real closed field and let  $f_1, \dots, f_n \in \mathbf{TR}[\mathbf{x}]$  such that the tropical hypersurfaces  $V(f_i^\nu)$  intersect transversally. Moreover, let  $\mathbf{h} \in (\mathbf{S}^*)^n$  and denote*

$$G = \text{ac}^{-1}\{\mathbf{h}\} \cap \nu^{-1}\left(\bigcap_{i=1}^n V(f_i^\nu)\right) \subseteq (\mathbf{TR}^*)^n.$$

*Then we have*

$$N_{\mathbf{h}}^{\text{sign}}(f_1^{\text{ac}}, \dots, f_n^{\text{ac}}) \geq \sum_{\mathbf{g} \in G} m^{\mathbf{S}}(\mathbf{g}; f_1 \cdots f_n).$$

*Proof.* First, note that the inequality

$$N_{\mathbf{h}}^{\text{sign}}(f_1^{\text{ac}}, \dots, f_n^{\text{ac}}) \geq \sum_{\mathbf{g} \in G} m^{\mathbf{S}}(\mathbf{g}; f_1 \cdots f_n)$$

can be formulated in the language of real closed fields. Since the theory of real closed fields is complete (see e.g. [Mar02, Chapter 3.3]), we may assume that  $K$  is a valued real closed field with surjective valuation. We pick, for  $1 \leq i \leq n$ , a polynomial  $g_i \in K[\mathbf{x}]$  with



$g_i^{\nu_{\text{sgn}}} = f_i$ . Then we have

$$\begin{aligned} N_{\mathbf{h}}^{\text{sign}}(f_1^{\text{ac}}, \dots, f_n^{\text{ac}}) &\geq \left| \bigcap_{i=1}^n V(g_i) \cap \text{sign}^{-1}\{\mathbf{h}\} \right| = \\ &= \sum_{\mathbf{g} \in G} \left| \bigcap_{i=1}^n V(g_i) \cap \nu_{\text{sgn}}^{-1}\{\mathbf{g}\} \right| = \sum_{\mathbf{g} \in G} m^{\mathbf{S}}(\mathbf{g}; f_1 \cdots f_n), \end{aligned}$$

where the last equality follows from Theorem 4.4.6.  $\square$

**Definition 4.4.9.** Let  $f_1, \dots, f_n \in \mathbf{S}[\mathbf{x}]$ , let  $h \in (\mathbf{S}^*)^n$ , and let  $\tilde{F}$  be the sets of tuples  $(\tilde{f}_1, \dots, \tilde{f}_n)$  of polynomials  $\tilde{f}_i \in \mathbf{TR}[\mathbf{x}]$  with  $\tilde{f}_i^{\text{ac}} = f_i$  and such that  $V(\tilde{f}_1^{\nu}), \dots, V(\tilde{f}_n^{\nu})$  intersect transversally. In analogy to the perturbation multiplicity, we define

$$\epsilon\text{-}N_{\mathbf{h}}(f_1, \dots, f_n) = \max \left\{ \sum_{\mathbf{g} \in G(\mathbf{h}; \tilde{f}_1, \dots, \tilde{f}_n)} m^{\mathbf{S}}(\mathbf{g}; \tilde{f}_1 \cdots \tilde{f}_n) : (\tilde{f}_i)_i \in \tilde{F} \right\},$$

where

$$G(\mathbf{h}; \tilde{f}_1, \dots, \tilde{f}_n) = \text{ac}^{-1}\{\mathbf{h}\} \cap \nu^{-1} \left( \bigcap_{i=1}^n V(\tilde{f}_i^{\nu}) \right).$$

The statement of Corollary 4.4.8 can now be rephrased as

$$N_{\mathbf{h}}^{\text{sign}}(f_1, \dots, f_n) \geq \epsilon\text{-}N_{\mathbf{h}}(f_1, \dots, f_n). \quad (4.3)$$

If we identify  $f_i \in \mathbf{S}[\mathbf{x}]$  with its signed Newton polytope and  $\mathbf{h}$  with the orthant of  $\mathbf{R}^n$  it determines, then the number  $\epsilon\text{-}N_{\mathbf{h}}(f_1, \dots, f_n)$  is precisely what is denoted by  $n((f_1, \dots, f_n), \mathbf{h})$  by Itenberg-Roy [IR96]. Corollary 4.4.8 follows from [IR96, Theorem 2]. Based on the inequality (4.3) and the idea that the tropically transverse case is the most degenerate and therefore that with the most real solutions, Itenberg and Roy conjectured [*loc. cit.*] that there is equality in (4.3). This was later disproven by Li and Wang with an explicit counterexample [LW98]. We will revisit that counterexample below in Example 4.4.11.

### 4.4.3 Resultants over hyperfields

As before, let  $f_1, \dots, f_n \in H[\mathbf{x}]$ , where  $f_i = \sum_{\mathbf{a} \in A_i} d_{i,\mathbf{a}} \mathbf{x}^{\mathbf{a}}$ , let  $h \in (H^*)^n$ , and let  $\varphi: K \rightarrow H$  be a morphism from a field  $K$  to  $H$ . We wish to give an upper bound for

$$N_{\mathbf{h}}^{\varphi}(f_1, \dots, f_n)$$

in terms of the multiplicities introduced in the previous section. Recall that  $R_{f_1, \dots, f_n}$  denotes the set of polynomials in  $H[\mathbf{y}]$  obtained by taking the sparse resultant of the supports of the  $f_i$  and the support of  $k = 1 + \sum y_i x_i$ , and plugging in the coefficients of the  $f_i$  and  $k$ .

**Theorem 4.4.10.** *Let  $l = 1 + \sum_{i=1}^n h_i x_i$ . Then with the notation as above we have*

$$N_{\mathbf{h}}^{\varphi}(f_1, \dots, f_n) \leq \text{mult}_l^{\varphi}(R_{f_1, \dots, f_n}).$$

*In particular, we have  $N_{\mathbf{h}}^{\varphi}(f_1, \dots, f_n) \leq \text{mult}_l(R_{f_1, \dots, f_n})$ .*

*Proof.* Given  $g_i \in \varphi^{-1}\{f_i\}$  for  $1 \leq i \leq n$  with  $\bigcap_{i=1}^n V(g_i)$  finite, we have

$$R_{g_1, \dots, g_n}^{\varphi} \in R_{f_1, \dots, f_n}.$$

By Lemma 4.4.1, it follows that

$$\begin{aligned} \left| \bigcap_{i=1}^n V(g_i) \cap \varphi^{-1}\{\mathbf{h}\} \right| &= \text{mult}_{\varphi^{-1}\{l\}}^K(R_{g_1, \dots, g_n}) \leq \\ &\leq \text{mult}_{\varphi^{-1}\{l\}}^K(\varphi^{-1}\{R_{f_1, \dots, f_n}\}) = \text{mult}_l^{\varphi}(R_{f_1, \dots, f_n}). \end{aligned}$$

□

In the remainder of this section, we analyze the utility of Theorem 4.4.10 in two explicit examples. Our computations rely on the help of the Singular Computer Algebra System [Sing].

**Example 4.4.11.** Let  $a, b, r, s, t$  be positive reals and consider the polynomial system in two variables given by

$$\begin{cases} f := 1 + ax - by = 0 \\ g := 1 + rx^3 - sy^3 - tx^3y^3 = 0 \end{cases}$$

Li and Wang showed that for appropriate choices of  $a, b, r, s, t$  the system has 3 positive real solutions [LW98]. This served as a counterexample to the Itenberg-Roy conjecture that predicted at most 2 real solutions. We now show that a resultant computation can predict the correct bound. As before, we introduce an auxiliary linear form

$$l := 1 + ux + vy$$

with parameters  $u, v$ , compute a multiple of the sparse resultant of  $l, f$ , and  $g$  and then specialize to the sign hyperfield to obtain a set of signed polynomials in  $u$  and  $v$ . In this set of signed polynomials, some but not all coefficients have a constant sign (up to multiplying everything by  $-1$ ). We use the following Singular code to compute the resultant.

```
system("random", 12341234);
ring R = (0, (u, v, a, b, r, s, t)), (x, y), dp;
ideal I = 1+ux+vy, 1+ax-by, 1+rx^3-sy^3-tx^3y^3;
module m = mpresmat(I, 0);
det(m) / b^9; // simplify by dividing by b^9
```

This gives (abbreviating terms with multiple signs)

$$\begin{aligned}
& u^6(\dots) + u^5v(\dots) - 3u^5ab^3s + u^4v^2(\dots) - 9u^4va^2b^2s + 3u^4a^2b^3s + u^3v^3(\dots) \\
& \quad + u^3v^2(\dots) + u^3v(\dots) + u^3(\dots) + u^2v^4(\dots) + u^2v^3(\dots) \\
& \quad + u^2v^2(9a^4bs + 9ab^4r + 9abt) + u^2v(\dots) + 3u^2ab^3t + uv^5(\dots) + 9uv^4a^2b^2r \\
& \quad + uv^3(\dots) + uv^2(\dots) - 9uva^2b^2t - 3ua^2b^3t + v^6(\dots) + 3v^5a^3br + 3v^4a^3b^2r \\
& \quad \quad \quad + v^3(\dots) + 3v^2a^3bt + 3va^3b^2t + a^3b^3t.
\end{aligned}$$

Specializing to the sign hyperfield, we obtain the set of signed polynomials in  $u$  and  $v$  represented in Figure 4.10. The maximal boundary multiplicity of the polynomials in this set is 3, the constants coming from for the lower boundary. Since we know that this bound can be achieved by [LW98], the boundary-multiplicity is equal to the multiplicity in this case. ◇

```

*
+ *
+ + *
* * * *
+ * + * *
+ - * * - *
+ - + * + - *

```

Figure 4.10: A multiple of the signed sparse resultant of  $f$ ,  $g$  and  $l$ . A  $*$  means the sign is undetermined.

Note that signed resultants are not always the best way to look at certain problems, as the next example shows.

**Example 4.4.12.** We compute a multiple of the resultant of  $1 + ux + vy$ ,  $1 + ax + by$  and  $1 + tx + rx^2 - sy^2$  using the following code:

```

system("random", 12341234);
ring R = (0, (u, v, a, b, r, s, t)), (x, y), dp;

```

```

ideal I = 1+ux+vy, 1+ax+by, 1+rx2-sy2+tx;
module m = mpresmat(I, 0);
det(m) / b; // simplify by dividing by b

```

The result is the polynomial in  $u$  and  $v$  given by

$$\begin{aligned}
 &u^2(b^2 - s) + uv(-ab + bt) + u(2as - b^2t) + \\
 &+ v^2(a^2 - at + r) + v(abt - 2br) - a^2s + b^2r.
 \end{aligned}$$

None of the signs of the coefficients are determined, so our bound is 2. But clearly  $a, b > 0$  implies that the system cannot have any positive solutions.  $\diamond$

**APPENDIX A**  
**FACTORIZATION RULES**

Within Baker and Lorscheid’s paper [BL21a], the author’s previous paper [Gun22a], and a paper of Agudelo and Lorscheid [AL21] are some descriptions of various division algorithms. Agudelo and Lorscheid spell out these algorithms explicitly and in the other two the algorithms are hidden inside the proofs. In this section, we describe these algorithms and explain where and how they appear in each of the aforementioned papers.

**Example A.0.1.** Over the Krasner hyperfield, with  $m < n$ , we have the following factorization:

$$x^m + \text{any intermediate terms} + x^n \preceq (x + 1)(x^m + x^{m+1} + x^{m+2} + \cdots + x^{n-1}).$$

Moreover, this factorization is optimal (the multiplicity of the quotient is exactly 1 less). Therefore  $\text{mult}_1^K f = n - m$  for any polynomial with highest term  $x^n$  and lowest term  $x^m$ . ◇

The existence of this rule was alluded to in [BL21a] but not spelled out. This rule is easy to verify and this verification is left to the reader.

**Example A.0.2.** Let  $f = \sum s_i x^i$  be a polynomial over the sign hyperfield with no intermediate zeroes between the lowest and highest term. Let  $i_0$  be the smallest index for which  $s_i = s_{i+1}$ . Define a new sequence of signs by “squishing together”  $s_{i_0}$  and  $s_{i_0+1}$ , so

$$\tilde{s}_i = \begin{cases} s_i & \text{if } i \leq i_0, \\ s_{i+1} & \text{if } i > i_0. \end{cases}$$

Then  $g = \sum \tilde{s}_i x^i$  is a quotient of  $f$  by  $(x + 1)$  and  $\text{mult}_{-1}^S g$  is exactly one less than

$\text{mult}_{-1}^{\mathbf{S}} f$ .

For instance,

$$1 - x + x^2 - x^3 - x^4 - x^5 + x^6 \asymp (1 + x)(1 - x + x^2 - x^3 - x^4 + x^5). \quad \diamond$$

**Example A.0.3.** If we apply the previous rule to factoring out  $(x - 1)$  by making the substitution  $x \mapsto -x$  before and after, we get this rule:

$$\tilde{s}_i = \begin{cases} -s_i & \text{if } i \leq i_0, \\ s_{i+1} & \text{if } i > i_0 \end{cases}$$

where  $i_0$  is now the smallest index where  $s_i \neq s_{i+1}$ . From the previous example, if we substitute  $x \mapsto -x$ , the odd coefficients flip. Then, after “squishing” the parity changes so we get a different sign before and after the squish.

For example,

$$1 + x + x^2 - x^3 + x^4 - x^5 \asymp (-1 + x)(-1 - x - x^2 + x^3 - x^4). \quad \diamond$$

Examples A.0.2 and A.0.3 follow from a more general description which we will see next.

**Example A.0.4.** Let  $f = \sum s_i x^i$  be a polynomial over the sign hyperfield, which for simplicity we assume has a nonzero constant term (otherwise factor out a monomial). Then as in Example A.0.3, let  $i_0$  be the smallest index  $i$  such that  $s_i \neq s_{i_0}$ .

Then from left-to-right, define

$$\tilde{s}_i = -s_i = -s_0 \text{ for } i \leq i_0$$

and for  $i > i_0$ , let  $\tilde{s}_i = s_{j(i)}$  where  $j(i) = \min\{j : j > i \text{ and } s_j \neq 0\}$  (i.e. the next non-zero

coefficient after  $s_i$ ). Then  $g = \sum \tilde{s}_i x^i$  is a quotient of  $f$  by  $x - 1$  and  $g$  has exactly one less sign change—equivalently one less positive root.  $\diamond$

This rule first appeared in Baker and Lorscheid’s paper [BL21a, proof of Theorem C]. In the author’s previous paper, this rule is extended to the tropical real hyperfield [Gun22a, proof of Theorem A]. In Agudelo and Lorscheid’s paper, the rule is adapted to apply to both factoring out  $x - 1$  and  $x + 1$ .

In the context of this paper, the rule is obtained from the proof of Theorem 3.C in the paragraphs before Claims 3 and 4 where we interpret  $i_0, i_0 + 1$  as the “middle.” For instance, the function  $j(i)$  defined in the previous example is a sibling of the function  $j(i)$  defined before Claim 4. For the left portion, the rule we gave was  $\tilde{s}_i \preceq \tilde{s}_{i-1} - s_i$  which is certainly true if we define  $\tilde{s}_i = -s_0 = -s_1 = -s_2 = \dots = -s_{i_0}$  for all  $i \leq i_0$ .

**Example A.0.5.** Let  $f$  be a polynomial over the tropical hyperfield and let  $a \in \mathbf{T}^\times$  be a root of  $f$ . Then to get a quotient of  $f$  by  $(x + a)$ , first replace  $f$  by  $f(ax)$ . Then apply Example A.0.1 to factor the initial form  $\text{in}_0 f$ . Then lift that factorization to a factorization of  $f$  by using the staircase rules illustrated in Figure 3.4 and described in the proof of Theorem 3.C.

Specifically, on the left, let  $d_i = \min\{d_{i-1}, c_i\}$  and on the right, let  $d_i = c_{j(i)}$  where  $j(i) = \min\{j : j > i \text{ and } c_j \text{ is minimal}\}$ .  $\diamond$

This rule is also described in [AL21] without first making the substitution  $f \mapsto f(ax)$ . In [BL21a], an entirely different approach is given to tropical polynomials via looking at polynomial functions.



## REFERENCES

- [AL21] Alexander Agudelo and Oliver Lorscheid. “Factorizations of tropical and sign polynomials”. In: *Indag. Math. (N.S.)* 32.4 (2021), pp. 797–812. DOI: 10.1016/j.indag.2021.04.005. arXiv: 2005.12882 [math.NT].
- [AGG14] Marianne Akian, Stéphane Gaubert, and Alexander Guterman. “Tropical Cramer determinants revisited”. In: *Tropical and idempotent mathematics and applications*. Vol. 616. Contemp. Math. Amer. Math. Soc., Providence, RI, 2014, pp. 1–45. DOI: 10.1090/conm/616/12324. arXiv: 1309.6298 [math.CO].
- [AGR22] Marianne Akian, Stéphane Gaubert, and Louis Rowen. *Semiring systems arising from hyperrings*. 2022. arXiv: 2207.06739 [math.RA].
- [AGT23] Marianne Akian, Stéphane Gaubert, and Hanieh Tavakolipour. *Factorization of polynomials over the symmetrized tropical semiring and Descartes’ rule of sign over ordered valued fields*. 2023. arXiv: 2301.05483 [math.RA].
- [Alb43] A. A. Albert. “An inductive proof of Descartes’ rule of signs”. In: *Amer. Math. Monthly* 50 (1943), pp. 178–180. DOI: 10.2307/2302399.
- [AGS20] Xavier Allamigeon, Stéphane Gaubert, and Mateusz Skomra. “Tropical spectrahedra”. In: *Discrete Comput. Geom.* 63.3 (2020), pp. 507–548. DOI: 10.1007/s00454-020-00176-1. arXiv: 1610.06746 [math.AG].
- [Ami+15] Omid Amini et al. “Lifting harmonic morphisms I: metrized complexes and Berkovich skeleta”. In: *Research in the Mathematical Sciences* 2.1 (June 2015), p. 7. DOI: 10.1186/s40687-014-0019-0. arXiv: 1303.4812 [math.AG].
- [An+14] Yang An et al. “Canonical representatives for divisor classes on tropical curves and the matrix-tree theorem”. In: *Forum Math. Sigma* 2 (2014), e24, 25. DOI: 10.1017/fms.2014.25. arXiv: 1304.4259 [math.CO].
- [Bak08a] Matthew Baker. “An introduction to Berkovich analytic spaces and non-Archimedean potential theory on curves”. In: *p-adic geometry*. Vol. 45. Univ. Lecture Ser. Amer. Math. Soc., Providence, RI, 2008, pp. 123–174. DOI: 10.1090/ulect/045/04.
- [Bak08b] Matthew Baker. “Specialization of linear systems from curves to graphs”. In: *Algebra Number Theory* 2.6 (2008). With an appendix by Brian Conrad, pp. 613–653. DOI: 10.2140/ant.2008.2.613. arXiv: math/0701075 [math.NT].

- [BB19] Matthew Baker and Nathan Bowler. “Matroids over partial hyperstructures”. In: *Adv. Math.* 343 (2019), pp. 821–863. DOI: [10.1016/j.aim.2018.12.004](https://doi.org/10.1016/j.aim.2018.12.004). arXiv: 1709.09707 [math.CO].
- [BL21a] Matthew Baker and Oliver Lorscheid. “Descartes’ rule of signs, Newton polygons, and polynomials over hyperfields”. In: *Journal of Algebra* 569 (2021), pp. 416–441. DOI: <https://doi.org/10.1016/j.jalgebra.2020.10.024>. arXiv: 1811.04966 [math.NT].
- [BL21b] Matthew Baker and Oliver Lorscheid. “The moduli space of matroids”. In: *Advances in Mathematics* 390 (2021), p. 107883. DOI: <https://doi.org/10.1016/j.aim.2021.107883>. arXiv: 1809.03542 [math.AG].
- [BPR13] Matthew Baker, Sam Payne, and Joseph Rabinoff. “On the structure of non-Archimedean analytic curves”. In: *Tropical and non-Archimedean geometry*. Vol. 605. Contemp. Math. Amer. Math. Soc., Providence, RI, 2013, pp. 93–121. DOI: [10.1090/conm/605/12113](https://doi.org/10.1090/conm/605/12113). arXiv: 1404.0279 [math.AG].
- [BPR16] Matthew Baker, Sam Payne, and Joseph Rabinoff. “Nonarchimedean geometry, tropicalization, and metrics on curves”. In: *Algebr. Geom.* 3.1 (2016), pp. 63–105. DOI: [10.14231/AG-2016-004](https://doi.org/10.14231/AG-2016-004). arXiv: 1104.0320 [math.AG].
- [BR15] Matthew Baker and Joseph Rabinoff. “The skeleton of the Jacobian, the Jacobian of the skeleton, and lifting meromorphic functions from tropical to algebraic curves”. In: *Int. Math. Res. Not. IMRN* 2015.16 (2015), pp. 7436–7472. DOI: [10.1093/imrn/rnu168](https://doi.org/10.1093/imrn/rnu168). arXiv: 1308.3864 [math.AG].
- [BZ23] Matthew Baker and Tianyi Zhang. “Fusion rules for pastures and tracts”. In: *European Journal of Combinatorics* 108 (2023), p. 103628. DOI: <https://doi.org/10.1016/j.ejcb.2022.103628>. arXiv: 2107.11700 [math.CO].
- [Ber90] Vladimir G. Berkovich. *Spectral theory and analytic geometry over non-Archimedean fields*. Vol. 33. Mathematical Surveys and Monographs. American Mathematical Society, Providence, RI, 1990. ISBN: 0-8218-1534-2.
- [BD17] Frédéric Bihan and Alicia Dickenstein. “Descartes’ rule of signs for polynomial systems supported on circuits”. In: *Int. Math. Res. Not. IMRN* 22 (2017), pp. 6867–6893. DOI: [10.1093/imrn/rnw199](https://doi.org/10.1093/imrn/rnw199). arXiv: 1601.05826 [math.AG].
- [BDF21] Frédéric Bihan, Alicia Dickenstein, and Jens Forsgård. “Optimal Descartes’ rule of signs for systems supported on circuits”. In: *Math. Ann.* 381.3-4 (2021), pp. 1283–1307. DOI: [10.1007/s00208-021-02216-4](https://doi.org/10.1007/s00208-021-02216-4). arXiv: 2010.09165 [math.AG].

- [BS21] Nathan Bowler and Ting Su. “Classification of doubly distributive skew hyperfields and stringent hypergroups”. In: *Journal of Algebra* 574 (2021), pp. 669–698. DOI: <https://doi.org/10.1016/j.jalgebra.2021.01.031>. arXiv: 2003.03751 [math.RA].
- [Car+16] Dustin Cartwright et al. “Embeddings and immersions of tropical curves”. In: *Collect. Math.* 67.1 (2016), pp. 1–19. DOI: [10.1007/s13348-015-0149-8](https://doi.org/10.1007/s13348-015-0149-8). arXiv: 1409.7372 [math.CO].
- [Che+16] Man-Wai Cheung et al. “Faithful realizability of tropical curves”. In: *Int. Math. Res. Not. IMRN* 2016.15 (2016), pp. 4706–4727. DOI: [10.1093/imrn/rnv269](https://doi.org/10.1093/imrn/rnv269). arXiv: 1410.4152 [math.AG].
- [CC11] Alain Connes and Caterina Consani. “The hyperring of adèle classes”. In: *J. Number Theory* 131.2 (2011), pp. 159–194. DOI: [10.1016/j.jnt.2010.09.001](https://doi.org/10.1016/j.jnt.2010.09.001). arXiv: 1001.4260 [math.AG].
- [Cur18] D. R. Curtiss. “Recent extensions of Descartes’ rule of signs”. In: *Ann. of Math.* (2) 19.4 (1918), pp. 251–278. DOI: [10.2307/1967494](https://doi.org/10.2307/1967494).
- [Sing] Wolfram Decker et al. *SINGULAR 4-3-0 — A computer algebra system for polynomial computations*. <http://www.singular.uni-kl.de>. 2022.
- [FT22] Elisenda Feliu and Máté L. Telek. “On generalizing Descartes’ rule of signs to hypersurfaces”. In: *Adv. Math.* 408, part A (2022), Paper No. 108582, 29. DOI: [10.1016/j.aim.2022.108582](https://doi.org/10.1016/j.aim.2022.108582). arXiv: 2107.10002 [math.AG].
- [GKZ94] Isreal M. Gel’fand, Mikhail M. Kapranov, and Andrei V. Zelevinsky. *Discriminants, resultants, and multidimensional determinants*. Mathematics: Theory & Applications. Birkhäuser Boston, Inc., Boston, MA, 1994. ISBN: 0-8176-3660-9. DOI: [10.1007/978-0-8176-4771-1](https://doi.org/10.1007/978-0-8176-4771-1).
- [Gra99] David J. Grabiner. “Descartes’ rule of signs: another construction”. In: *Amer. Math. Monthly* 106.9 (1999), pp. 854–856. DOI: [10.2307/2589619](https://doi.org/10.2307/2589619).
- [Gun22a] Trevor Gunn. “A Newton Polygon Rule for Formally-Real Valued Fields and Multiplicities over the Signed Tropical Hyperfield”. In: (2022). arXiv: 1911.12274 [math.RA].
- [Gun22b] Trevor Gunn. “Tropical Extensions and Baker-Lorscheid Multiplicities for Idylls”. In: (2022). arXiv: 2211.06480 [math.RA].
- [Har77] Robin Hartshorne. *Algebraic geometry*. Graduate Texts in Mathematics, No. 52. Springer-Verlag, New York-Heidelberg, 1977. ISBN: 0-387-90244-9.

- [HT11] Pentti Haukkanen and Timo Tossavainen. “A generalization of Descartes’ rule of signs and fundamental theorem of algebra”. In: *Appl. Math. Comput.* 218.4 (2011), pp. 1203–1207. DOI: 10.1016/j.amc.2011.05.107.
- [HS95] Birkett Huber and Bernd Sturmfels. “A polyhedral method for solving sparse polynomial systems”. In: *Math. Comp.* 64.212 (1995), pp. 1541–1555. DOI: 10.2307/2153370.
- [IR96] Ilya Itenberg and Marie-Françoise Roy. “Multivariate Descartes’ rule”. In: *Beiträge Algebra Geom.* 37.2 (1996). <https://eudml.org/doc/233019>, pp. 337–346.
- [JP22] Andrés Jaramillo Puentes and Sabrina Pauli. “Quadratically enriched tropical intersections”. 2022. arXiv: 2208.00240 [math.AG].
- [Jel20] Philipp Jell. “Constructing smooth and fully faithful tropicalizations for Mumford curves”. In: *Selecta Math. (N.S.)* 26.4 (2020), Paper No. 60, 23. DOI: 10.1007/s00029-020-00586-2. arXiv: 1805.11594 [math.AG].
- [JSY22] Philipp Jell, Claus Scheiderer, and Josephine Yu. “Real tropicalization and analytification of semialgebraic sets”. In: *Int. Math. Res. Not. IMRN* 2 (2022). [Initially appeared as 2021, no. 24, 19178–19208], pp. 928–958. DOI: 10.1093/imrn/rnaa112. arXiv: 1810.05132 [math.AG].
- [JY16] Anders Jensen and Josephine Yu. “Stable intersections of tropical varieties”. In: *J. Algebraic Combin.* 43.1 (2016), pp. 101–128. DOI: 10.1007/s10801-015-0627-9. arXiv: 1309.7064 [math.AG].
- [Jun21] Jaiung Jun. “Geometry of hyperfields”. In: *J. Algebra* 569 (2021), pp. 220–257. DOI: 10.1016/j.jalgebra.2020.11.005. arXiv: 1707.09348 [math.AG].
- [Kom06] Vilmos Komornik. “Another short proof of Descartes’s rule of signs”. In: *Amer. Math. Monthly* 113.9 (2006), pp. 829–830. DOI: 10.2307/27642066.
- [Kri63] P. V. Krishnaiah. “A Simple Proof of Descartes’ Rule of Signs”. In: *Math. Mag.* 36.3 (1963), p. 190.
- [LW98] T. Y. Li and Xiaoshen Wang. “On multivariate Descartes’ rule—a counterexample”. In: *Beiträge Algebra Geom.* 39.1 (1998). <https://eudml.org/doc/228888>, pp. 1–5.
- [Liu20] Ziqi Liu. “Examples on the sharpness of an inequality about multiplicities over hyperfields”. 2020. DOI: 10.48550/arXiv.2010.09492. arXiv: 2010.09492 [math.NT].

- [Lor12] Oliver Lorscheid. “The geometry of blueprints: Part I: Algebraic background and scheme theory”. In: *Advances in Mathematics* 229.3 (2012), pp. 1804–1846. DOI: <https://doi.org/10.1016/j.aim.2011.12.018>. arXiv: 1103.1745 [math.AG].
- [Lor15] Oliver Lorscheid. “A unifying approach to tropicalization”. 2015. DOI: 10.48550/ARXIV.1508.07949. arXiv: 1508.07949.
- [Lor18a] Oliver Lorscheid. “ $\mathbb{F}_1$  for everyone”. In: *Jahresber. Dtsch. Math.-Ver.* 120.2 (2018), pp. 83–116. DOI: 10.1365/s13291-018-0177-x. arXiv: 1801.05337 [math.AG].
- [Lor18b] Oliver Lorscheid. “The geometry of blueprints: Part II: Tits-Weyl models of algebraic groups”. In: *Forum Math. Sigma* 6 (2018), Paper No. e20, 90. DOI: 10.1017/fms.2018.17. arXiv: 1201.1324 [math.AG].
- [Lor18c] Oliver Lorscheid. *Blueprints and tropical scheme theory*. <https://oliver.impa.br/notes/2018-Blueprints/versions/lecturenotes180509.pdf>. 2018.
- [MS15] Diane Maclagan and Bernd Sturmfels. *Introduction to tropical geometry*. Vol. 161. Graduate Studies in Mathematics. American Mathematical Society, Providence, RI, 2015. ISBN: 978-0-8218-5198-2. DOI: 10.1090/gsm/161.
- [Mar02] David Marker. *Model theory*. Vol. 217. Graduate Texts in Mathematics. An introduction. Springer-Verlag, New York, 2002. ISBN: 0-387-98760-6.
- [Mas85] Christos G. Massouros. “Methods of constructing hyperfields”. In: *Internat. J. Math. Math. Sci.* 8.4 (1985), pp. 725–728. DOI: 10.1155/S0161171285000813.
- [MZ08] Grigory Mikhalkin and Ilia Zharkov. “Tropical curves, their Jacobians and theta functions”. In: *Curves and Abelian Varieties*. Vol. 465. Contemp. Math. Amer. Math. Soc., Providence, RI, 2008, pp. 203–230. DOI: 10.1090/conm/465/09104. arXiv: math/0612267 [math.AG].
- [Pay09] Sam Payne. “Analytification is the limit of all tropicalizations”. In: *Math. Res. Lett.* 16.3 (2009), pp. 543–556. DOI: 10.4310/MRL.2009.v16.n3.a13. arXiv: 0805.1916 [math.AG].
- [Row22] Louis Halle Rowen. “Algebras with a negation map”. In: *Eur. J. Math.* 8.1 (2022), pp. 62–138. DOI: 10.1007/s40879-021-00499-0. arXiv: 1602.00353 [math.RA].

- [Stu94a] Bernd Sturmfels. “On the Newton polytope of the resultant”. In: *J. Algebraic Combin.* 3.2 (1994), pp. 207–236. DOI: 10.1023/A:1022497624378.
- [Stu94b] Bernd Sturmfels. “Viro’s theorem for complete intersections”. In: *Ann. Scuola Norm. Sup. Pisa Cl. Sci. (4)* 21.3 (1994), pp. 377–386.
- [Thu05] Amaury Thuillier. “Théorie du potentiel sur les courbes en géométrie analytique non archimédienne. Applications à la théorie d’Arakelov.” Thèse. Université Rennes 1, Oct. 2005.
- [Tok11] Daniel V Tokarev. “A generalisation of Descartes’ rule of signs”. In: *J. Aust. Math. Soc.* 91.3 (2011), pp. 415–420.
- [Vir89] O. Ya. Viro. “Real plane algebraic curves: constructions with controlled topology”. In: *Algebra i Analiz* 1.5 (1989), pp. 1–73.
- [Vir10] Oleg Viro. “Hyperfields for Tropical Geometry I. Hyperfields and dequantization”. Jan. 2010. arXiv: 1006.3034 [math.AG].
- [Vir11] Oleg Ya. Viro. “On basic concepts of tropical geometry”. In: *Proceedings of the Steklov Institute of Mathematics* 273.1 (July 2011), pp. 252–282. DOI: 10.1134/S0081543811040134.
- [Wag17] Till Wagner. “Faithful tropicalization of Mumford curves of genus two”. In: *Beiträge zur Algebra und Geometrie / Contributions to Algebra and Geometry* 58.1 (Mar. 2017), pp. 47–67. DOI: 10.1007/s13366-015-0272-4. arXiv: 1408.0120 [math.AG].
- [Wan04] Xiaoshen Wang. “A simple proof of Descartes’s rule of signs”. In: *Amer. Math. Monthly* 111.6 (2004), pp. 525–526.